



OTTERPOOL PARK

COUNTRYSIDE • CONNECTED • CREATIVE

TRANSPORT ASSESMENT | VOLUME 2
APPENDICES A TO F

www.otterpoolpark.org

 **ARCADIS**

Author: Arcadis
February 2019

APPENDIX A – Transport Assessment Scoping Note

OTTERPOOL PARK

Transport Assessment Scoping Report

OCTOBER 2018

Incorporating

EC HARRIS
BUILT ASSET
CONSULTANCY



CONTENTS

1	INTRODUCTION AND BACKGROUND	1
1.1	Introduction	1
1.2	Consultation	1
1.3	Structure of this Note	4
2	POLICY AND TECHNICAL CONTENT	5
2.1	Policy	5
2.2	Technical Guidance	5
3	BASELINE	7
3.1	Introduction	7
3.2	Data Collection	7
3.2.1	Desk-top information	7
3.2.2	On-site information	7
3.3	Baseline Scenarios	8
3.4	Site Location and Description	8
3.5	Pedestrian and Cycle Networks	8
3.6	Public Transport	8
3.7	Local Highway Network	8
3.8	Adjacent Developments	9
3.9	On-Street Parking	9
3.10	Road Safety	9
3.11	Committed Developments	9
4	ASSESSMENT METHODS AND FORECASTING	10
4.1	Development Proposals	10
4.2	Temporal Scope of Assessment	10
4.3	Trip Generation, Mode Share and Distribution	10
4.4	Method of Assessment	10
4.4.1	General Approach	10
4.4.2	Pedestrian and Cycle Routes	10
4.4.3	Public Transport	10
4.4.4	Highway Capacity	11
4.5	Implementation Plan	14

TABLES

Table 1 Kent County Council / Folkestone & Hythe District Council Comments on Scope of Transport Assessment	1
Table 2 Folkstone & Hythe District Council Comments on Scope of Transport Assessment	2
Table 3 Highways England Comments on Scope of Transport Assessment	2
Table 4 Ashford Borough Council Comments on Scope of Transport Assessment	3
Table 5 Canterbury City Council Comments on Scope of Transport Assessment.....	3
Table 6 Junctions to be Assessed.....	12

APPENDICES

APPENDIX A

Scoping information submitted to KCC to agree scope of work required in Canterbury

APPENDIX B

Vehicle Traffic Survey Data Provided by Folkstone & Hythe District Council

Vehicle Traffic Survey Data Provided by Corinthian Mountfield Ltd

APPENDIX C

Vehicle Traffic Survey Data Collected July 2017

APPENDIX D

ANPR Data Collected July 2017

APPENDIX E

Local Footpaths and Bridleways

APPENDIX F

Extent of VISUM model

Extent of VISSIM model

1 Introduction and Background

1.1 Introduction

Arcadis Consulting (UK) Limited was appointed in August 2016 to develop a masterplan and planning submission in respect of the proposed garden settlement called Otterpool Park.

A Transport Assessment (TA) will be produced to accompany the planning application, which is anticipated to be submitted in 2018, that will set out the transport issues relating to the development proposals. Measures will be identified to mitigate adverse transport effects of the scheme. Consideration will be given to the effects on all modes of travel.

In August 2017, a Scoping Report¹ was issued to Kent County Council (KCC), Folkstone & Hythe District Council (F&H DC) and Highways England (HE) to provide a description of the work proposed to be undertaken as part of the TA and set out the proposed technical, spatial and temporal scope of the TA. This Report represents a revision of the August 2017 report incorporating comments received during scoping discussions.

1.2 Consultation

A number of consultation meetings have been held with KCC, SDC and Highways England (HE) to allow methodologies and outcomes to be agreed. In addition, consultation events have been held involving wider stakeholders. Comments have also been received from Canterbury City Council. The comments received and the action taken to reach a resolution to each comment is summarised in Table 1 to Table 5.

Table 1 Kent County Council / Folkestone & Hythe District Council Comments on Scope of Transport Assessment

Issue Raised	Resolution
Regional Policy – Growth Without Gridlock has now been superseded by LTP 4 which was adopted by KCC at a cabinet a few weeks ago and should therefore be removed	Noted and removed.
Technical Guidance – I would also suggest you include KCC's Interim Guidance Notes 1, 2 and 3 in your technical reference documents	Noted and included.
Baseline Scenarios – We would also expect there to be a baseline scenario for the year of planning application (2018), you could simply use TEMPro growth figures to increase the traffic count data from the baseline traffic counts	2018 included as baseline year of assessment. TEMPro used to derive growth factors.
Traffic Data – Although the use of October 2016 data is acceptable, it should be subject to TEMPRO growth rates to reflect the baseline condition at the year of application.	
Local Highway Network – The four baseline scenarios should be obtained from SDC from the District Transport Model	Further discussions concluded that forecast traffic is to be calculated using TEMPro adjusted to include the most recent housing and employment forecasts.
Committed Development – Again the future baseline traffic data should be provided by SDC from the District Transport Model	
Assessment years and scenarios – Do we know what is the completion date of the Otterpool Park development? If this is different to 2037 then it may need to be included in the assessment year scenario.	Completion year of 2044 to be included in assessment.

¹ Otterpool Park Garden Settlement Transport Assessment Scoping Report (Arcadis, August 2017)

Otterpool Park
Transport Assessment Scoping Report

Issue Raised	Resolution
Operation Stack is an emergency procedure I do not think it is appropriate to include this within the assessment.	Noted and agreed.
<p>We feel that the following two junctions need to be included in the junction assessment together with the proposed capacity improvements by the South Canterbury site:</p> <ol style="list-style-type: none"> 1) Nackington Road / Old Dover Road 2) Old Dover Road / The Drive / St Lawrence Road 	These two junctions have been included in the assessment.

Table 2 Folkstone & Hythe District Council Comments on Scope of Transport Assessment

Issue Raised	Resolution
On the Lorry Park issue we do not think it needs to be scoped in at this stage. The main caveat to this is if details emerge later on and the ES needs to be reviewed at some point then this position might be subject to change but at the moment we can't speculate on what the outcome of the consultation will be and it is too early in the process.	Noted and agreed.
Merge/diverge assessments will be required.	Noted and included in assessment.

Table 3 Highways England Comments on Scope of Transport Assessment

Issue Raised	Resolution
The baseline is proposed to be 2017 - this should be reflective of the year of submission e.g. 2018	2018 included as baseline year of assessment.
Future forecast year is proposed to be 2037 to reflect end of local plan period. The 2037 forecast will include the full development scheme. We will required information on what phases / proportion of the development will be built by 2037 and what will be after that. If a significant proportion of the development will be post-2037 we may require a further future year forecast.	Completion year of 2044 to be included in assessment.
Peak hours are to be assessed (0800-0900 and 1700-1800) – agreed this is sensible however will need to be confirmed on review of traffic survey data.	This has been confirmed through analysis of traffic survey data.
Committed development is to be taken into account. This should include consideration of the overnight parking element of the Lorry Holding Area (500 spaces) and all sites allocated within relevant Local Plan(s). We would also wish to receive your thoughts on how Otterpool will incorporate resilience such that it continues to be able to operate when the likes of Operation Stack (or it's successors) are implemented.	A strategy to maintain resilience during periods of implementation of Operation Stack will be included.
Dependant on traffic flow volumes, there may be a requirement for merge / diverge assessments as per DMRB TD22/06 at relevant junctions.	Noted and included in assessment.

Otterpool Park
Transport Assessment Scoping Report

Issue Raised	Resolution
<p>The assessment of M20 J9 in terms of percentage increases in flows is not agreed – in terms of the percentage impact approach, a small percentage increase in a large volume of traffic could be a large number of additional vehicles. Equally in some places a single additional vehicle could cause safety and/ or operational issues at a junction. Therefore percentage increases in flows are not considered appropriate when assessing impacts/mitigation. While increase in traffic volume is an element which needs to be considered a key concern will be the impact of the development on safety and operation, which relates to changes in queues and delays. We will therefore require evidence that the proposed development will not increase queues and delays to a point where they impact the safety and operation of the SRN.</p>	<p>M20 Junction 9 is included in the assessment. Effects of the development will be summarised in terms of changes in queues and delays between the 'Do Minimum' forecast year without Otterpool Park development and the 'Do Something' forecast year with Otterpool Park development.</p>
<p>Consideration of the impact of the development on M20 J10a should also be included.</p>	<p>M20 Junction 10A is included in the assessment.</p>
<p>We would question any forecasting based upon SERTM. This model is effectively a base from which more detailed models can be produced as it has limited disaggregation of matrices and limited network coverage. Any forecasts even those produced recently are likely to be out of date as Local Authority OANs locally (Ashford, Shepway and Dover for example) are evolving all the time</p>	<p>Forecast traffic has been calculated using TEMPro adjusted to include the most recent housing and employment forecasts.</p>
<p>Use of TEMPro factors would be acceptable but you will need to check that the household and employment assumptions are correct. Given that OAN is calculated locally they can be out of date on TEMPro release or soon after.</p>	

Table 4 Ashford Borough Council Comments on Scope of Transport Assessment

Issue Raised	Resolution
<p>We point out the importance of considering the impacts of this development on the rural road network, particularly in its westward movements along the B2067 along the Saxon Shore, and along the Roman Road which runs through Aldington.</p>	<p>Impacts on the B2067 Aldington Road at the junction with Otterpool Lane has been included in the assessment, as agreed with KCC.</p>

Table 5 Canterbury City Council Comments on Scope of Transport Assessment

Issue Raised	Resolution
<p>Committed growth in the Canterbury District Local Plan 2017 should be considered.</p>	<p>Most recent forecasts of housing and employment for Canterbury have been used to derive TEMPro forecasts.</p>
<p>This growth will need to be taken account of in the assessment if developments are within a reasonable distance of the Otterpool Park site and are considered likely to have the potential to generate significant traffic effects.</p>	<p>The significance of likely effects generated by Otterpool Park on routes into Canterbury was investigated and discussed with KCC. It was subsequently agreed to include the Nackington</p>

Issue Raised	Resolution
modelling includes routes into Canterbury, particularly Stone Street and Nackington Road.	Road / Old Dover Road and Old Dover Road / The Drive / St Lawrence Road junctions within the assessment. Information submitted as part of this scoping process is included in Appendix A to this Scoping Report.

This revised Scoping Report incorporates the comments and changes described above.

1.3 Structure of this Note

The remainder of this Note is structured as follows:

- Chapter 2 Policy and Technical Content**
- Chapter 3 Baseline**
- Chapter 4 Assessment Methods and Forecasting**

2 Policy and Technical Content

2.1 Policy

The TA will include a summary of current transport planning policy and planning guidance in the context of the sites and the surrounding area. The TA will demonstrate how the development complies with transport and other relevant policies.

Relevant transport policies at the national, regional and local level will be outlined. The following documents will be consulted:

National Policy:

1. National Planning Policy Framework (NPPF) (March 2012 and various updates);
2. The Strategic Road Network and the Delivery of Sustainable Development – Department for Transport (DfT) Circular 02/13 (DfT, September 2013);
3. The Strategic Road Network: Planning for the Future (Highways England, September 2015);

Regional Policy:

4. Local Transport Plan 4: Delivering Growth without Gridlock 2016-2031, (KCC, October 2016);
5. Supplementary Planning Guidance SPG4: Kent Vehicle Parking Standards (KCC, July 2006);

Local Policy:

6. Folkstone & Hythe Core Strategy, (F&H DC, 2013);
7. Folkstone & Hythe District Council Transport Strategy, (F&H DC, February 2011);
8. Places and Policies Local Plan, Preferred Options, (F&H DC, October 2016).

2.2 Technical Guidance

KCC guidelines for the preparation of TAs for development² have been archived along with the national guidelines³ produced by the DfT. TA guidance is now incorporated into the NPPF. Paragraph 32 of the NPPF states:

“All developments that generate significant amounts of movement should be supported by a Transport Statement or Transport Assessment. Plans and decisions should take account of whether:

- *the opportunities for sustainable transport modes have been taken up depending on the nature and location of the site, to reduce the need for major transport infrastructure;*
- *safe and suitable access to the site can be achieved for all people; and*
- *Improvements can be undertaken within the transport network that cost effectively limit the significant impacts of the development. Development should only be prevented or refused on transport grounds where the residual cumulative impacts of development are severe. “*

² Guidance on Transport Assessments and Travel Plans (KCC, October 2008)

³ Guidance on Transport Assessment (DfT, 2007)

A set of Planning Practice Guidance has been published to inform how the principle of the NPPF should be practiced. Those that specifically relate to transport matters are:

1. Travel Plans, Transport Assessments and Statements in Decision-Taking (March 2014); and
2. Transport Evidence Bases in Plan Making and Decision Taking (October 2014).

These guidelines provide a common approach which are aimed at ensuring that all relevant issues have been addressed within an assessment.

The TA for the Otterpool Park site will adopt the national guidelines and approaches where possible, taking account of the specific nature of the development. If divergence from the guidelines is required to address project-specific issues, an alternative approach will be discussed and agreed with KCC prior to the planning application submission.

Where appropriate a range of other technical reference documents will be consulted in developing the assessment and mitigation proposals. These may include:

1. The Kent Design Guide (Kent Design Initiative, December 2005);
2. Kent County Council Interim Guidance Notes 1, 2 and 3;
3. The Design Manual for Roads and Bridges, (DfT, various dates);
4. The Manual for Streets, (Department for Communities and Local Government (DCLG) / DfT, 2007);
5. The Manual for Streets 2, CIHT, 2010 – a companion guide to Manual for Streets (DCLG / DfT, 2010); and
6. Travel Plan Guidelines, (DfT, various dates).

3 Baseline

3.1 Introduction

Existing transport conditions in and around the site will be established to provide baseline data against which the potential effects arising from the scheme can be assessed.

Baseline observations will be informed by site visits, collation of available information from KCC, SDC and other sources and on-site data collection.

The following sections describe the baseline data to be provided within the TA report.

3.2 Data Collection

A variety of methods will be used to collect data that may be relevant to the preparation of the TA. These divide into two primary sources; 'desk-top' information and 'on-site' information.

3.2.1 Desk-top information

This information includes:

1. Accident record data for the most recent 36 months covering an area within the site boundary and up to 500m from it;
2. Bus timetable and routing information. Bus patronage data will be included if the data is made available;
3. Rail timetable and routing information. Rail patronage data will be included if the data is made available;
4. Traffic flow data provided by F&H DC, as listed in Appendix B;
5. Traffic flow data provided by Corinthian Mountfield Ltd, as listed in Appendix B;
6. Traffic signal timing data for all signalled junctions included in the scope of the highway capacity modelling. The list of junctions included in Chapter 4; and
7. Pedestrian and cycle route networks.

3.2.2 On-site information

A programme of on-site data collection has been developed through discussion with KCC/ F&H DC with the aim of undertaking the majority of the necessary field work prior to the end of September 2017.

The data to be collected is described in the following sections.

1. Manual classified vehicle turning counts: This data is being collected at junctions that are included in the scope of the highway capacity modelling, as described in Chapter 4. A list of junctions at which this data is to be collected is contained in Appendix C;
2. Automatic number plate recognition (ANPR) surveys: Locations at which ANPR data is to be collected is shown in Appendix D;
3. Pedestrian flow surveys: This data will be collected on the existing pedestrian network in the vicinity of the site. Appendix E presents the extent of the network on which survey data may be collected.

3.3 Baseline Scenarios

Four baseline scenarios will be created to inform the assessment. These will comprise:

1. 2018 pre-construction 'no scheme' baseline, drawing on existing data;
2. A future year 'no scheme' baseline, reflecting anticipated baseline conditions in 2037 at the end of the Local Plan period. The future year 'no scheme' baseline will make allowance for the effects of committed development or infrastructure schemes;
3. A future year 'no scheme' baseline, reflecting anticipated baseline conditions in 2044, the year of full build-out for the main scheme, including allowance for the effects of committed development or infrastructure schemes; and
4. A future year 'no scheme' baseline, reflecting anticipated baseline conditions in 2046, the year of full build-out for the aspirational masterplan scheme, including allowance for the effects of committed development or infrastructure schemes.

3.4 Site Location and Description

The TA will describe and illustrate the geographical location of the proposed site in relation to current land uses and the local transport networks and amenities.

3.5 Pedestrian and Cycle Networks

The TA will describe existing walking and cycling networks and facilities, including pedestrian / Toucan crossings, cycle routes and cycle parking.

Pedestrian and cycle flows derived from data collection sources will be presented.

3.6 Public Transport

The TA will outline existing public transport services operating in the area surrounding the site together with known proposals for new services.

The geographic threshold for considering public transport services will reflect the thresholds considered as accessible to the site, typically covering distances of 400m and 960m from the site for bus and rail services respectively.

Information will be provided on the routes/lines and frequency of nearby mainline rail services.

A review of the existing bus network will be undertaken to provide details on bus routes and frequencies to form the baseline for assessment. Any current enhancement proposals likely to be implemented during the construction period will be identified and included. This will be undertaken in conjunction with KCC and SDC.

Details of existing bus stop and stand locations and bus priority measures within the site boundary will be recorded.

Details of any specific taxi infrastructure, such as rank locations, will be included in the baseline conditions.

3.7 Local Highway Network

The TA will identify the road hierarchy, authority responsibilities and key elements of the surrounding highway network.

Existing traffic conditions on the local highway network will be established from traffic surveys and modelled data.

As agreed, baseline traffic forecasts for the four baseline scenarios will be obtained from KCC from the regional traffic model.

3.8 Adjacent Developments

The TA will identify existing access provision for parking and servicing at properties adjacent to the development to ensure that any effects on access to these properties are identified as part of the assessment.

3.9 On-Street Parking

The TA will identify existing on-street parking within the site boundary.

It will outline existing parking conditions, including on-street loading provision and controls.

3.10 Road Safety

The TA will include an analysis of accident data for the local roads within the site boundary and within 500 metres of it for the most recent 36 months of data available.

The analysis will consider the severity, casualty type and location of recorded accidents.

3.11 Committed Developments

The assessment will include traffic generation of committed and planned developments. Further information is provided in Chapter 4 of this Note.

The following committed transport infrastructure/improvement schemes will be taken into account:

1. New M20 Junction 10A and associated changes to the surrounding road network, including M20 Junction 10;
2. New signalised site access junction on A20 Hythe Road for Willesborough Lees development;
3. Traffic calming proposals and new site accesses through Sellindge Village proposed for the Sellindge residential development;
4. Adjustments to the flare length on the A261 Hythe Road at the junction with A20 Ashford Road required for the Land East of Ashford Road development;
5. A2034 Cheriton Road / A20 Cherry Garden Avenue junction and link proposals for the Folkstone Seafront masterplan;
6. Military Way parking suspension east of junction with Scanlons Bridge Road; and
7. Nackington Road / Old Dover Road and Old Dover Road / St Lawrence Road / The Drive proposals for the Mountfield Park development.

4 Assessment Methods and Forecasting

4.1 Development Proposals

The TA will include a description of the development proposals, including site layout, access strategies for vehicles, pedestrians and public transport, as well as outline parking and servicing proposals.

The TA will demonstrate the adequacy of access points in relation to capacity and vehicle manoeuvring. It will provide preliminary junction layouts and consider safety for all users.

4.2 Temporal Scope of Assessment

For each assessment year a weekday morning peak period (0800 to 0900) and a weekday evening peak period (1700 to 1800) will be assessed. This aligns with the local network peak periods as calculated from traffic survey data.

4.3 Trip Generation, Mode Share and Distribution

The method for the calculation of trip generation, the determination of trip mode share and the distribution of trips is described in a series of technical notes⁴⁵⁶ that form the agreement to the methods for use in the assessment with KCC and SDC.

These notes will be updated to reflect the agreed methods once discussions have been completed and provided as appendices to the Scoping Note once the scope is agreed.

4.4 Method of Assessment

4.4.1 General Approach

The methodology for the assessment will vary depending upon the mode of transport being examined. However, the general approach will be to assess the proposals, identify effects, determine any additional or different mitigation necessary, and revise the assessments accordingly.

4.4.2 Pedestrian and Cycle Routes

The TA will outline the assessed effects on pedestrian and cycle networks within the development site after full build-out and occupation, taking into account any committed pedestrian and cycle improvement schemes and any mitigation measures proposed as part of the Otterpool Park development. Consideration will also be given to linkages to key pedestrian or cycle destinations that would be affected by the project.

The assessment will identify the likely effects on pedestrians and cyclists in terms of severance, safety, altered journey times and the needs of mobility-impaired users.

4.4.3 Public Transport

The assessment of the public transport networks will identify the expected additional loads on local rail and bus connections based on the agreed mode share and assignment methodology. Where relevant, the assessment will use the outcomes of the highway network assessment to indicate whether road-based public transport services would be likely to experience changes in journey time.

The assessment will take account of any changes to infrastructure, network routing and frequencies resulting from committed public transport proposals and proposals that form part of the public transport access strategy for Otterpool Park.

⁴ Otterpool Park Garden Settlement Trip Generation Calculation Method Technical Note (Arcadis, September 2018)

⁵ Otterpool Park Garden Settlement Method for deriving Mode Splits (Arcadis, October 2018)

⁶ Otterpool Park Garden Settlement Method for the Distribution of External Vehicle Trips (Arcadis, October 2018)

4.4.4 Highway Capacity

4.4.4.1 Method and Scope of assessment

The extent of highway network to be included in the assessment was discussed with KCC, F&H DC and HE. KCC requested that a VISSIM model be produced to assess the local junctions most likely to be impacted by the development while a number of other junctions would be assessed using the appropriate LinSig, Arcady or Picady software. Merge/diverge assessments will be undertaken as appropriate. presents the existing and committed junctions identified for assessment.

Model validation reports were submitted to KCC, F&H DC and HE in May 2018. As of October 2018, discussions with HE on the VISSIM model are ongoing. If the VISSIM modelling is not completed in time for submission in the TA, the results and conclusions will be provided post-submission.

4.4.4.2 Method of Development Trip Assignment

The distribution of development vehicle flows between the site and a number of off-site origins/destinations has been calculated using a gravity model method. This distribution will be input a VISUM model to distribute the development flows on the network and allow us to identify the likely routing. The development flow distribution will be extracted from the VISUM model and input the LinSig, Arcady and VISSIM models statically. The VISUM model will be validated against the observed turning counts and journey time captured on site. The proposed extent of the VISUM and VISSIM models are shown in Appendix F.

4.4.4.3 Assessment years and scenarios

As described in Chapter 3, we anticipate the creation of four baseline scenarios; for 2018, 2037, 2044 and 2046. The 2044 scenario will form the main assessment, while the 2046 scenario will consider a sensitivity test of an extended masterplan scenario. Future year 'no-scheme' baseline scenarios will be created and used as the basis for forecasting the 'with-scheme' situation for each assessment year.

The assessment will add the expected transport network activity to the future year baseline scenarios.

The following assessment scenarios will be undertaken for each assessment year:

1. Base traffic flows + committed development traffic flows; and
2. Base traffic flows + committed development traffic flows + Otterpool Park development flows.

It was agreed with KCC and F&H DC that construction vehicle movements would occur outside of the local peak network periods and therefore would not be included in the assessment.

4.4.4.4 Traffic Data and Forecasting

The baseline and future baseline scenarios will be developed using traffic survey data to produce a set of baseline information to which forecast scheme traffic can be added.

Traffic count data for a number of the junctions in has been provided by F&H DC. This data was collected in October 2016 and it has been agreed that it is suitable for use for the assessment of the Otterpool Park development. Further traffic data has been collected in June 2017. The results of the surveys will be validated against the 2016 traffic counts. The data collected in June 2017 included Automatic Number Plate Recognition data for roundabouts, gyratories and all entries/exits to/from the VISSIM model area.

Initially it was agreed with KCC, SDC and HE that the future year base traffic flows would be provided from the strategic highway model. During the development of the modelling, HE suggested to obtain the future year base flows from the baseline flows applying TEMPro growth factors. Employment and household forecasts obtained from KCC were used to generate TEMPro growth factors. HE also suggested that a growth factor of 0.6% should be assumed for heavy goods vehicle traffic on the M20.

Otterpool Park
Transport Assessment Scoping Report

Table 6 Junctions to be Assessed

ID	Junction Name
J1	M20 J10
J2	M20 J11
J3	Ashford Road (A20) / Swan Lane
J4	Ashford Road (A20) / Stone Hill
J5	Hythe Road (A20) / Station Road / Church Road
J6	Hythe Road (A20) / Meersham
J7a	A2070 Kenniton Road / The Street
J7b	Hythe Road (A20) / The Street
J8	A20 Ashford Road / B2067 Otterpool Lane
J9	B2067 Otterpool Lane / Aldington Road
J10	Aldington Road / Stone Street
J11a	A20 Ashford Road / A261 Hythe Road / Stone Street
J11b	A20 Ashford Road / A261 Hythe Road / Stone Street
J12	Aldington Road / Lympe Hill
J13	A261 Hythe Road / Aldington Road
J14	A261 London Road / Barrack Hill
J15	A259 / Dymchurch Road / Military Road
J16	A259 Prospect Road / A259 East Road / Station Road / High Street
J17	A20 Ashford Road / A20 J11 offslip
J18	Ashford Road (A20) / Sandling Road
J19	M20 J11A
J20	M20 J12
J21a	M20 J13
J21b	M20 J13
J22	A20 Ashford Road / Stone Street
J23	M20 J9
J24	B2064 Cheriton High Street / B2063 Risborough Lane
J25	B2064 Cheriton High Street / A2034 Cherry Garden Avenue
J26	A259 Prospect Road / Stade Street
J27	Barrow Hill 1-way
SH18	A260 Spitfire Way / White Horse Hill / A20 Slip Roads
SH19	Alkham Valley Road / A20 slip roads
SH16	A260 Canterbury Road / Alkham Valley Road
J31	A20 Ashford Road access to P1B & P7
J32	A20 Ashford Road access to P6
J33	A20 Ashford Road Link Road west
J34	A20 Ashford Road access to P1A & P2A
J35	A20 Ashford Road Link Road east
J36	A20 Ashford Road Business Park access
J37	Otterpool Lane access to P1B
J38	Otterpool Lane access to P2B & P3B
J39	A20 Ashford Road Link Road / High Street
J40	Otterpool Lane P9 north
J41	Otterpool Lane P9 south
J42	M20 J10A
J43	A20 Ashford Rd small roundabout
J44	Nackington Road / Old Dover / Road Old Dover Rd / St Lawrence Rd / The Drive

4.4.4.5 Operation Stack / Lorry Park Proposals

It was agreed with KCC, F&H DC and HE that the effects of Operation Stack would not be assessed as it is an emergency procedure and is therefore not appropriate to include this within the assessment. As requested by HE, a strategy will be proposed to mitigate the effect of Operation Stack where possible if it occurs.

Since there are no committed scheme proposals for a Lorry Park and no planned scheme proposals are available, it is not possible to consider the potential affects of a Lorry Park in the assessment.

4.4.4.6 Highway mitigation

Where the assessment identifies effects which will require mitigation, appropriate mitigation solutions will be developed and discussed with KCC, F&H DC and, where necessary, HE.

Agreement will be sought on the most appropriate solutions to mitigate effects and the agreed solutions will be re-assessed and reported in the TA. If it is not possible to conclude discussions on mitigation requirements prior to submission of the TA, discussions will continue following submission.

4.5 Implementation Plan

The TA will present a proposed strategy for the coordination and implementation of the mitigation measures identified from the assessment.

This Implementation Plan will integrate the key elements of the construction logistics strategy, construction activity programme and identified mitigation measures to present a comprehensive strategy for managing and mitigation transport effects arising from the scheme.

The Implementation Plan is intended to act as the 'umbrella' under which more detailed discussions can take place with stakeholders during the construction phase. It will recognise the need for flexibility to respond to changing circumstances during the construction period, to allow all parties to review progress and address transport issues that may arise.

APPENDIX A

Scoping information submitted to KCC to agree scope of work required in Canterbury

Longman, Phillip

From: Longman, Phillip
Sent: 12 July 2018 13:15
To: colin.finch@kent.gov.uk; James.Hammond@folkestone-hythe.gov.uk;
Matt.Hogben@kent.gov.uk; sally.benge@kent.gov.uk
Cc: Kearney, Rebecca; Collins, Chad; Maria Rosa Gallego
Subject: Otterpool Park Canterbury Trip Distribution Assessment
Attachments: Otterpool Park Canterbury Trip Distribution v1.1.xlsx

Follow Up Flag: Follow up
Flag Status: Completed

Dear All

Following the request from Canterbury City Council to consider the impact of Otterpool Park on the City, I have extended our vehicle trip distribution model to include Canterbury in more detail. Previously, Canterbury was included in our distribution model as a single zone, which did not provide the vehicle routing of trips in enough detail to consider impact on individual junctions in Canterbury. We have now included Canterbury in our distribution model as 23 individual zones. The zones have been chosen by generating clusters of Lower Level Super Output Areas, as defined in Census 2011, according to the likely vehicle routing to each cluster. The attached spreadsheet shows the location of the centre of each zone in the sheet called "GM Zone Centres".

The 23 zones have been included in our three gravity models (one for incoming commuting trips, one for outgoing commuting trips and one for residential trips for non-work purposes), enabling us to determine the number of vehicle trips expected to be generated by the Otterpool Park development to/from each zone. The routes vehicles would take between each zone and Otterpool Park were determined using the vehicle routing tool on Google Maps.

This method of vehicle trip distribution is the method agreed with KCC, Folkestone & Hythe DC and Highways England for all other zones within our assessment area, including Ashford and Folkestone for which it had been necessary to consider likely vehicle routing in a similar level of detail.

You sent us a junction plan taken from the South Canterbury application (shown in sheet "Canterbury Junctions" in the spreadsheet) that identifies 11 existing junctions. The spreadsheet shows the distribution of Otterpool Park vehicle trips through these junctions for the AM and PM peak (sheets "AM Peak Devt Flows" and "PM Peak Devt Flows"). These flows are for full occupation of Otterpool Park at the end year (2044) of our main assessment.

We then extracted future base flows from the Mountfield Park Transport Assessment (sheet "2031 baseline"). These are the 2031 Base + Development flows for 4,000 homes + 45,000sqm commercial space. Sheets "2031 AM Base" and "2031 PM Base" show these trips on our network. We then compared our 2044 development trips to the 2031 baseline trips and calculated a percentage flow increase on each arm of each junction (sheets "Future AM %" and "Future PM %").

Our development flows through the junctions are low and the percentage flow increases range from less than 1% to up to 5%. As we are comparing 2044 development flows against a 2031 baseline, I would expect the flow increase against a 2044 baseline to be even lower.

I would be very grateful if you could review this information and let me know your thoughts on the requirement for further testing of these junctions in the Otterpool Park Transport Assessment.

Kind regards,

Phil

Phillip Longman
Associate Technical Director
Transport Planning & Urban Design

Phillip.Longman@arcadis.com

Arcadis Consulting (UK Limited)

Bernard Weatherill House, 8 Mint Walk, Croydon CR0 1EA

T: 020 3014 9100

www.arcadis.com



Be green, leave it on the screen.



Arcadis Consulting (UK) Limited is a private limited company registered in England & Wales (registered number 02212959). Arcadis House, 34 York Way, London, N1 9AB. Part of the Arcadis Group of Companies along with other entities in the UK.

OTTERPOOL PARK GARDEN SETTLEMENT

Canterbury Trip Distribution

v1.1

12 July 2018



Incorporating

EC HARRIS
BUILT ASSET
CONSULTANCY

 Hyder

Zone Centroids used in Trip Distribution Gravity Models

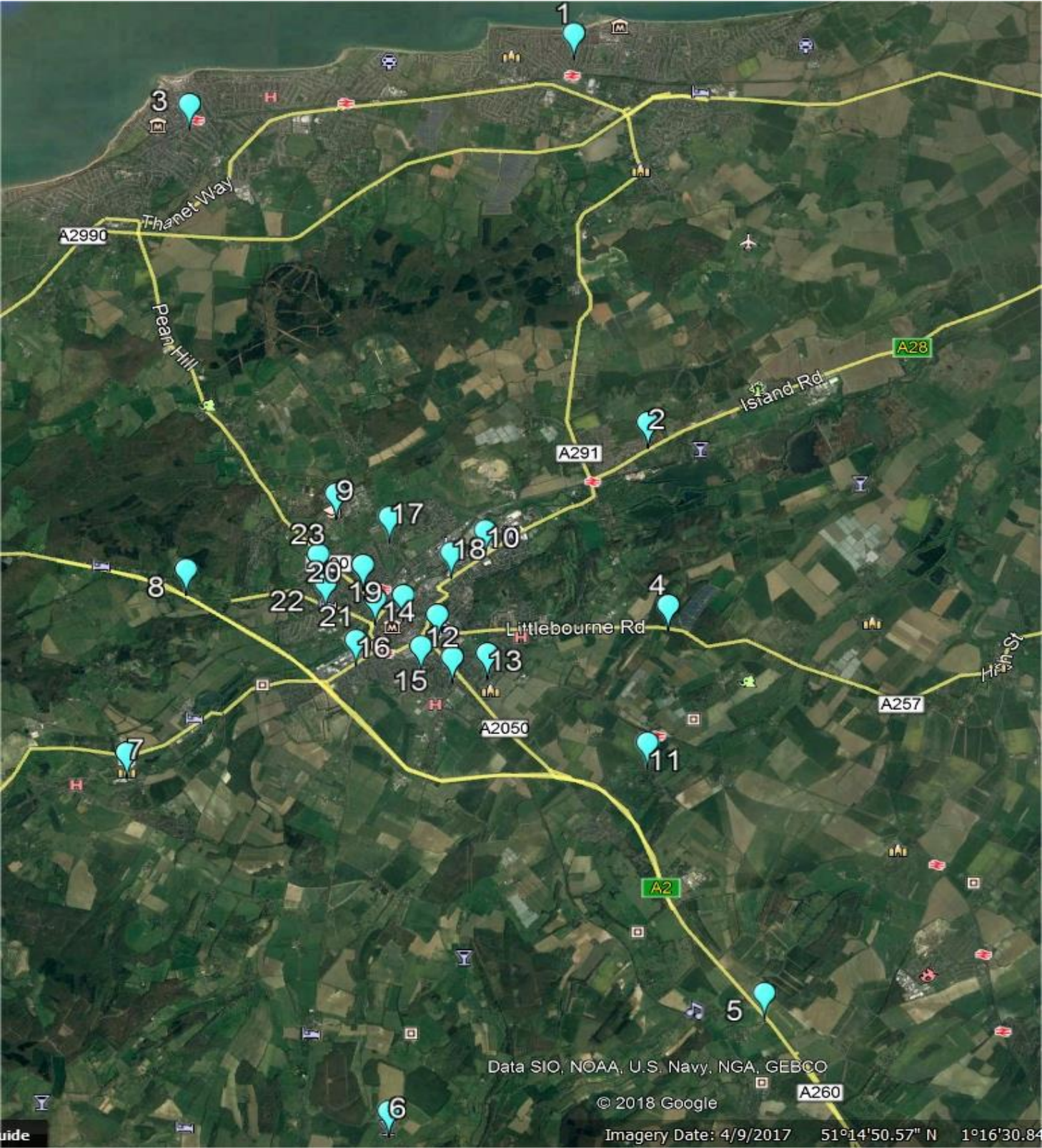

Canterbury Junctions for Analysis

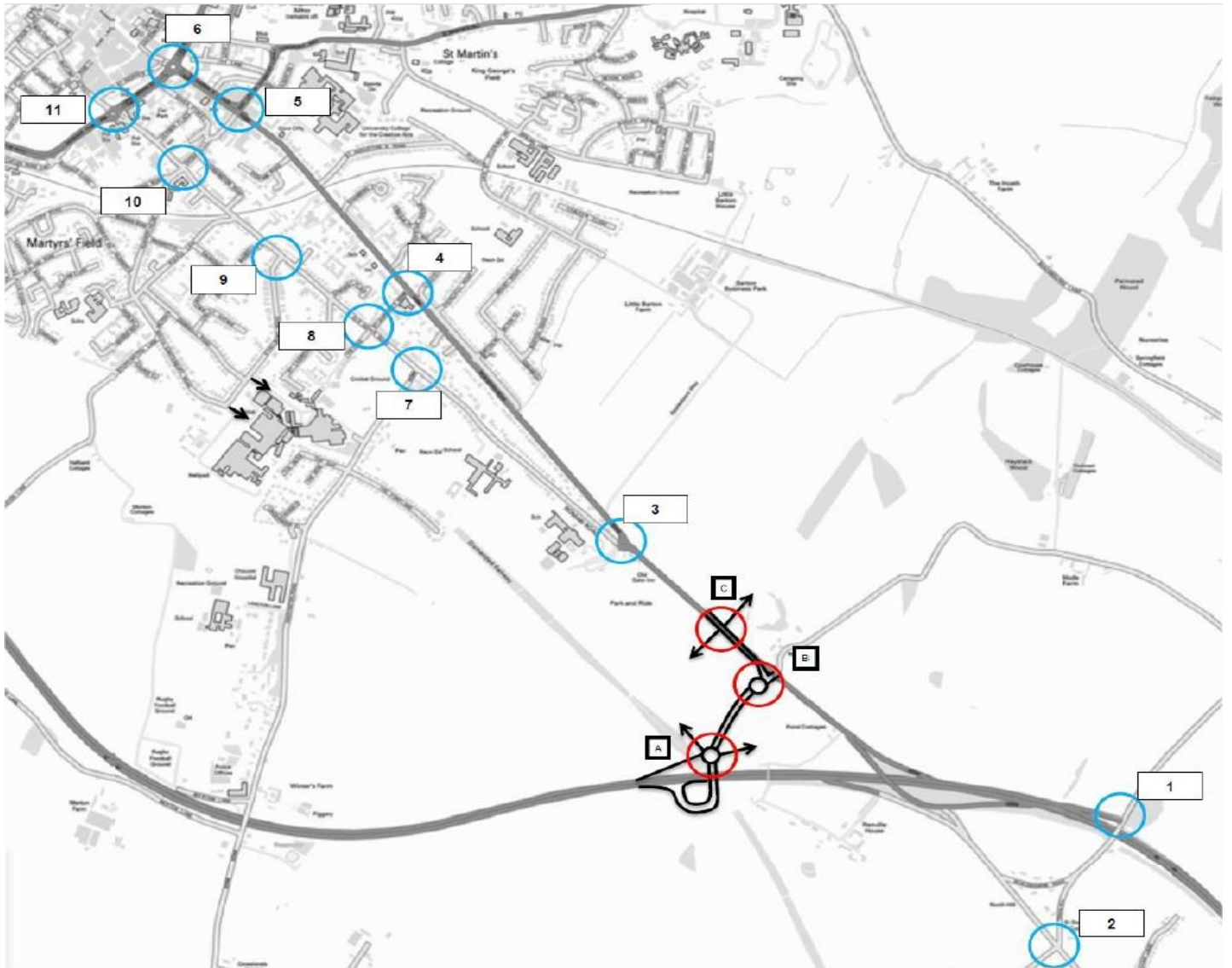

Ref.	
Junction 1	Bekesbourne Road/ A2 eastbound slip road
Junction 2	High Street/ Station Road/ Town Hill
Junction 3	Old Dover Road/ New Dover Road/ The Gate Inn/ P&R
Junction 4	New Dover Road/ St Lawrence Road
Junction 5	New Dover/ St George's Place/ Lower Chantry Lane
Junction 6	St George's Place/ A28 Lower Bridge Street
Junction 7	Old Dover Road/ Nackington Road
Junction 8	Old Dover Road/ St Lawrence Road
Junction 9	Ethelbert Road/ Old Dover Road
Junction 10	Old Dover Road/ Nunnery Fields/ Oaten Hill
Junction 11	Old Dover Road/ A28 Upper Bridge St

Canterbury-AM Peak Otterpool Park 2044 Development Flows

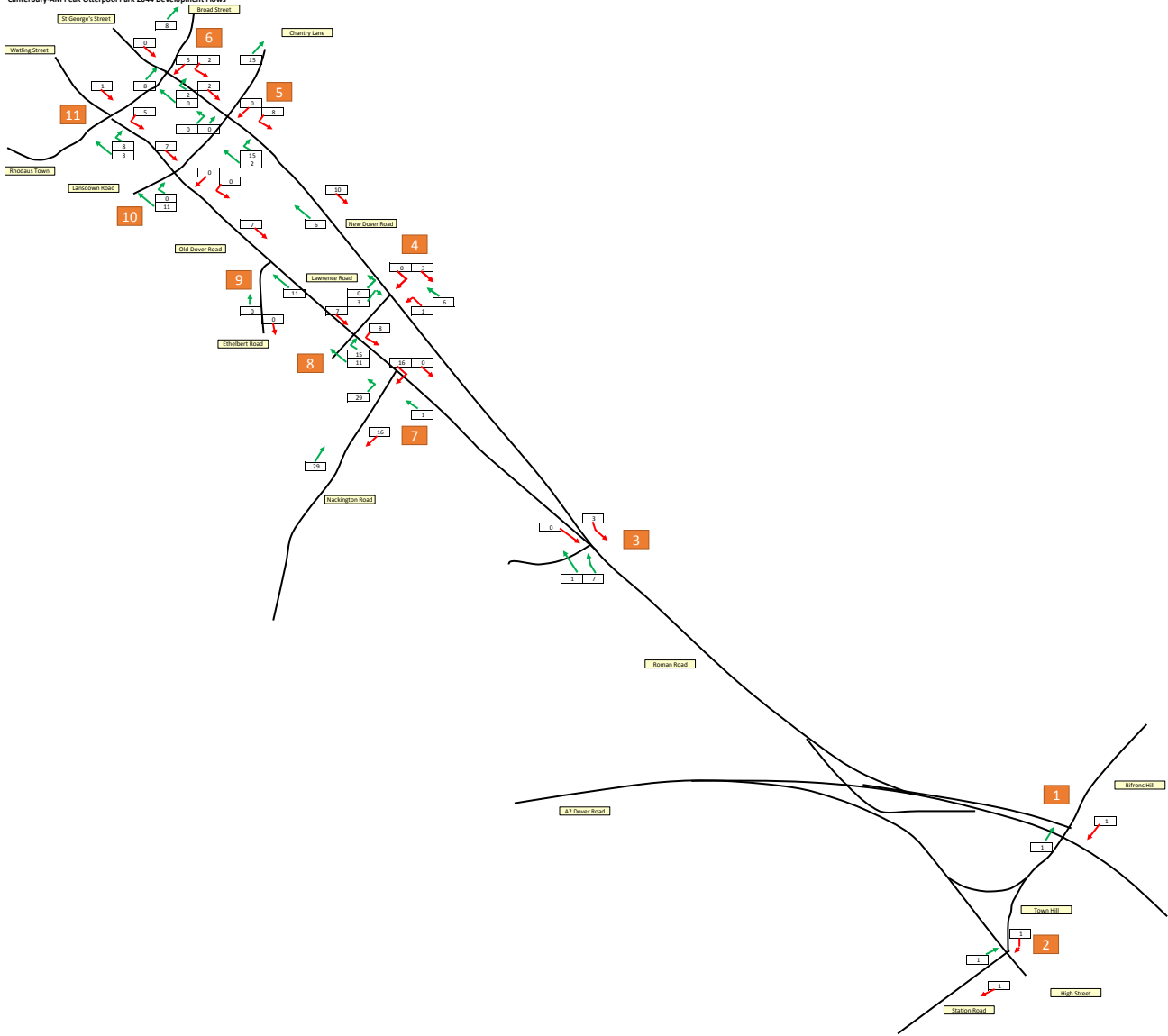

Canterbury-PM Peak Otterpool Park 2044 Development Flows

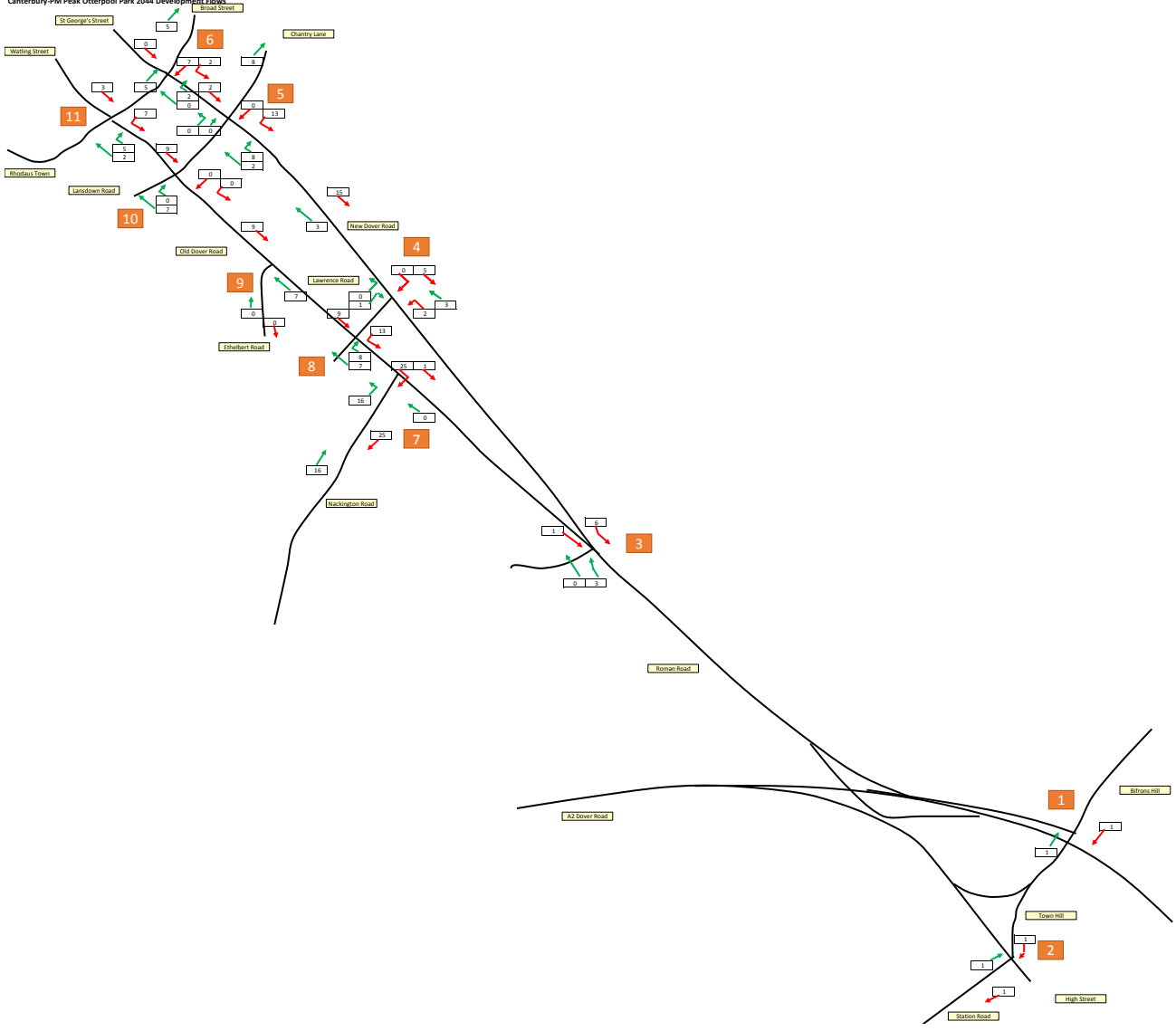

Canterbury 2031 Baseline Flows

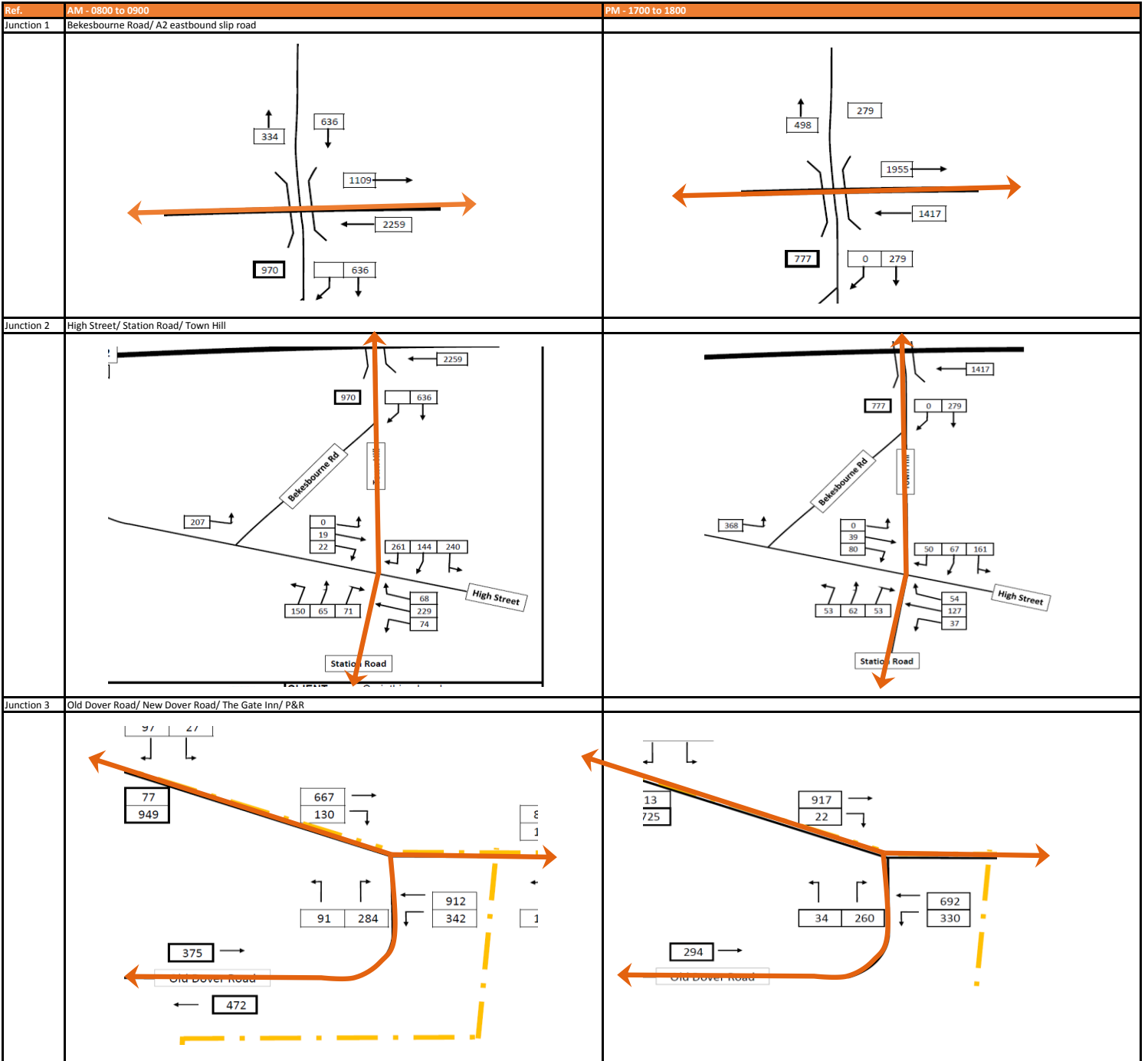

Canterbury 2031 Baseline Flows

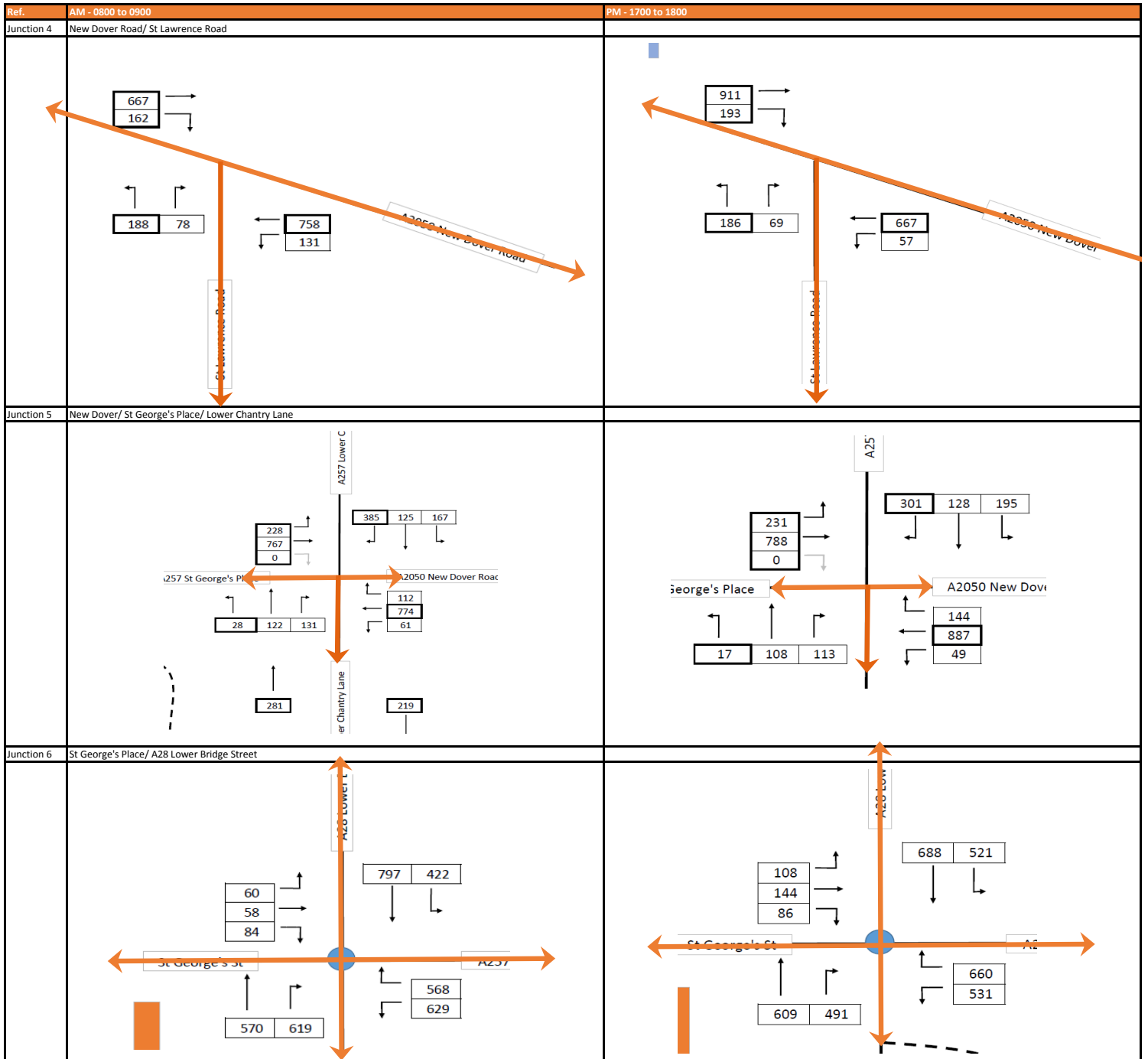

Canterbury 2031 Baseline Flows

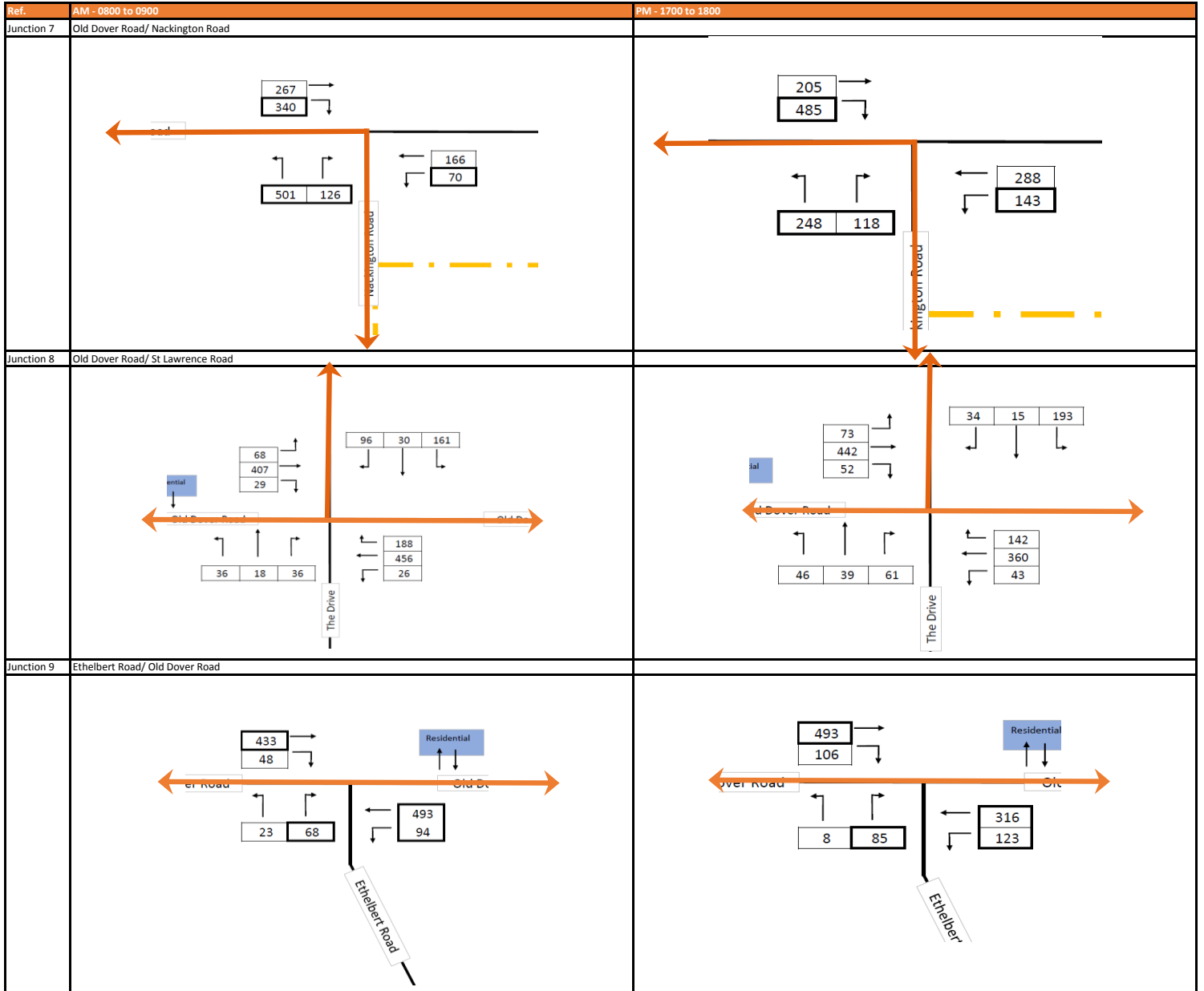

Canterbury 2031 Baseline Flows

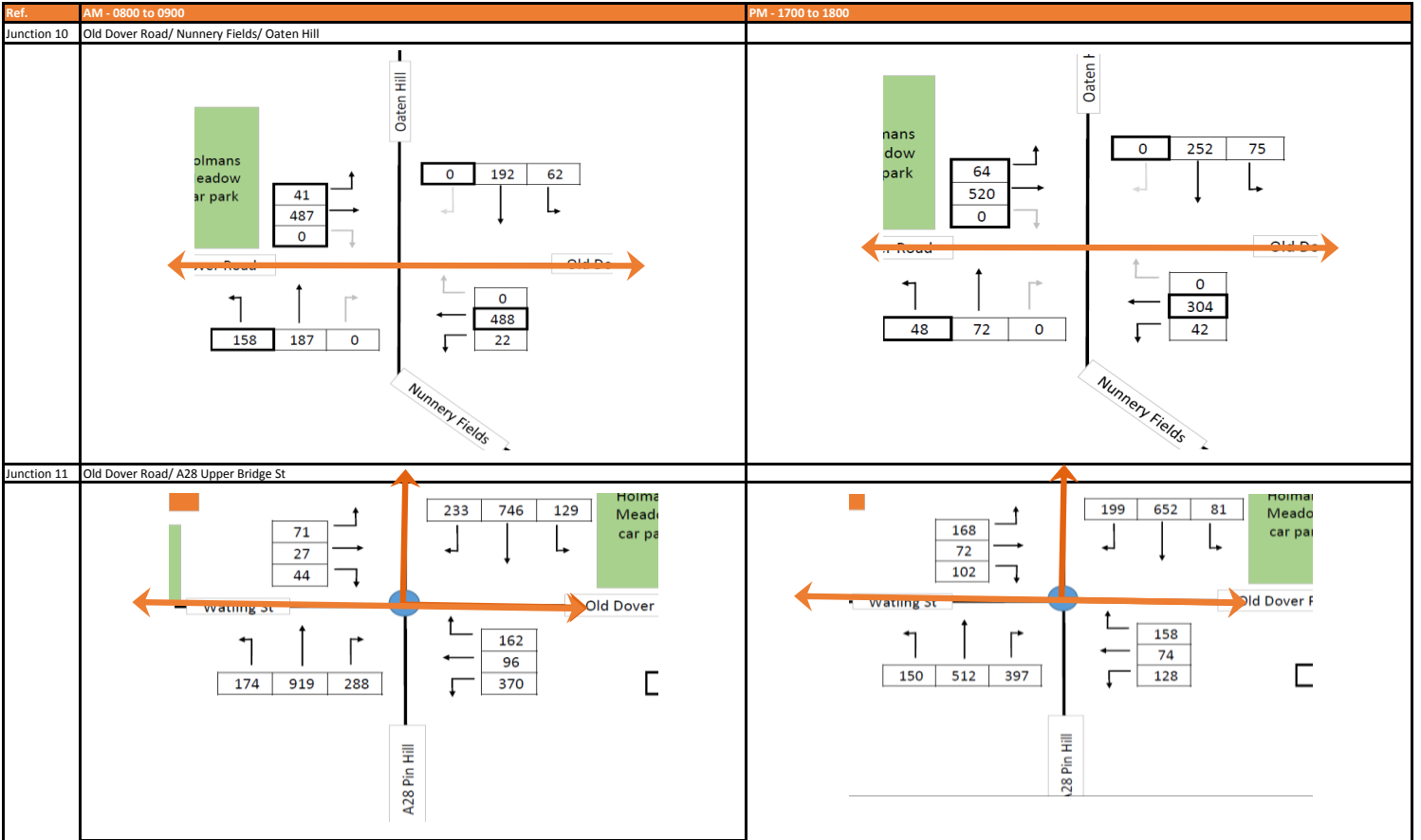

Canterbury-AM Peak Future Base 2031 Flows

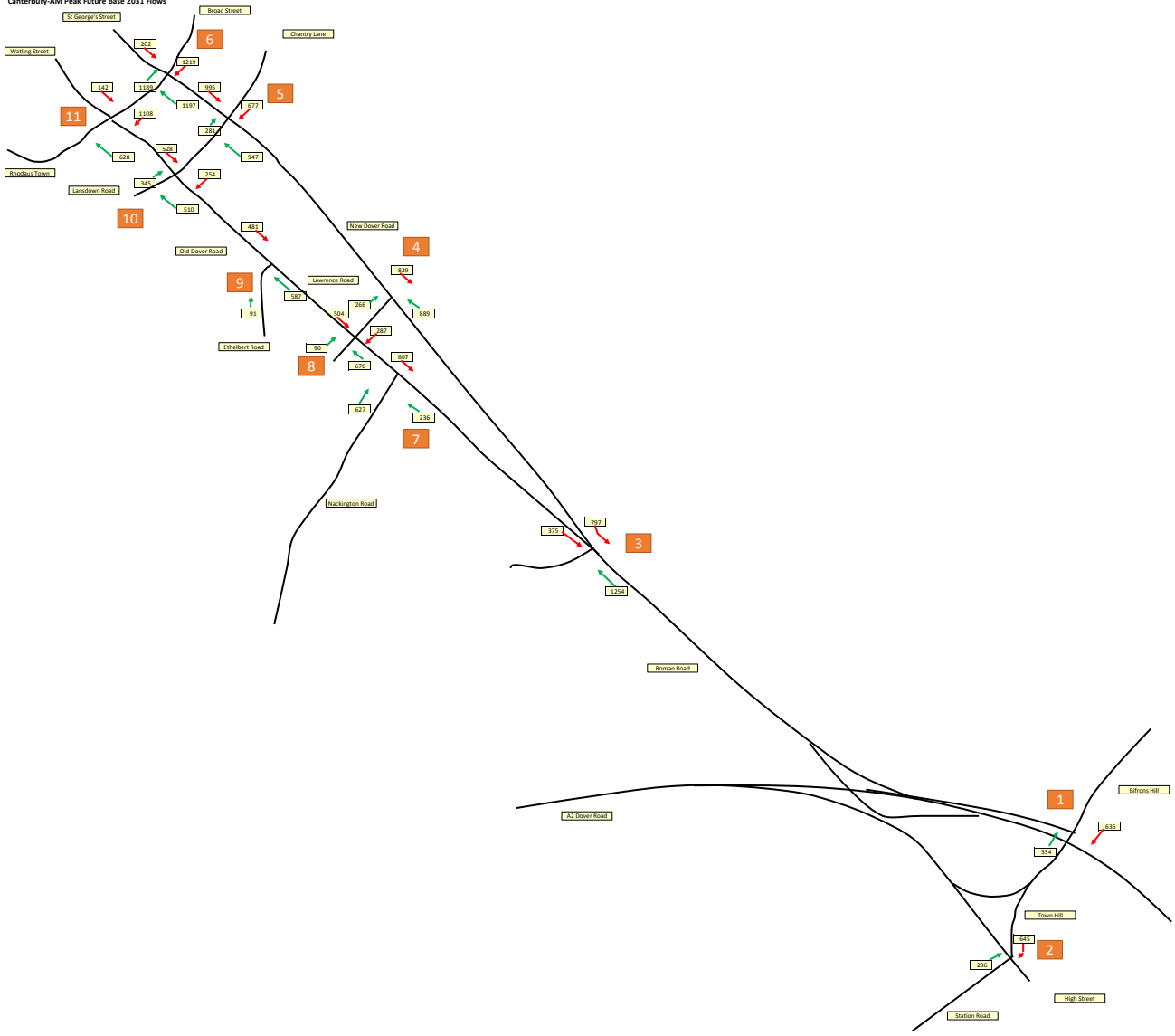

Canterbury-PM Peak Future Base 2031 Flows



Canterbury-AM Peak % impact 2031 Base + 2044 Development



Canterbury-PM Peak % Impact 2031 Base + 2044 Development

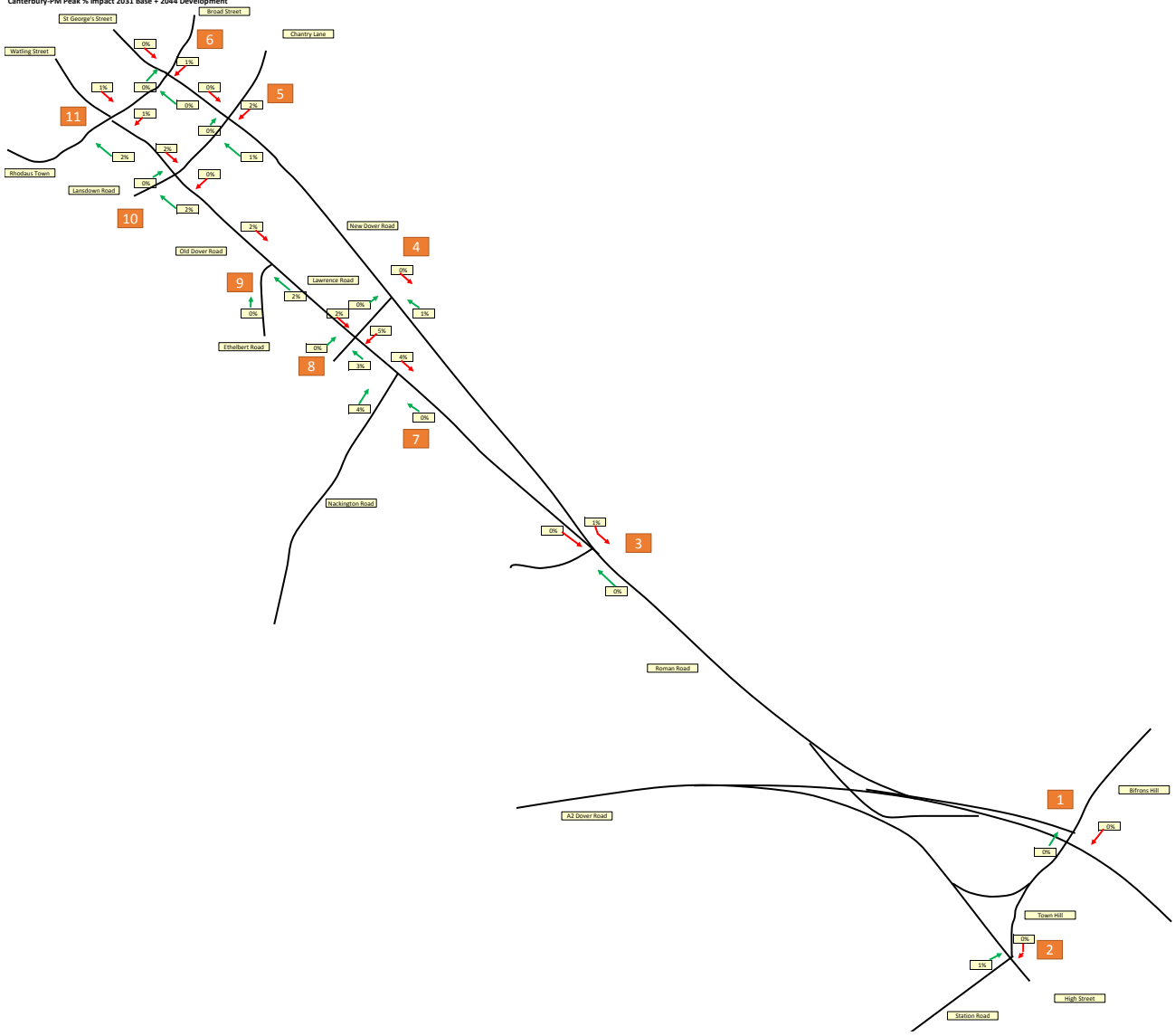

Longman, Phillip

From: Matt.Hogben@kent.gov.uk
Sent: 13 July 2018 09:04
To: Longman, Phillip; colin.finch@kent.gov.uk; James.Hammond@folkestone-hythe.gov.uk; sally.benge@kent.gov.uk
Cc: Kearney, Rebecca; Collins, Chad; Maria Rosa Gallego
Subject: RE: Otterpool Park Canterbury Trip Distribution Assessment

Follow Up Flag: Follow up
Flag Status: Completed

Hi Phil

Thank you for the e-mail. I have spoken to Colin on this matter. We feel that the following two junctions need to be included in the junction assessment together with the proposed capacity improvements by the South Canterbury site:

- 1) Nackington Road / Old Dover Road
- 2) Old Dover Road / The Drive / St Lawrence Road

Full details of the capacity improvements can be found in the South Canterbury Transport Assessment and Transport Assessment Addendum.

This is because the impact on these junctions is 5% and 4% respectively in the AM peak.

Furthermore we will be expecting the applicant to fund the provision of two new directional signs to the New Dover Road Park and Ride site from Faussett Hill and Bridge Road to sign drivers to use this route to access the Park and Ride site. This can be secured through a planning condition when planning permission is eventually granted for this site.

Regards

Matthew Hogben | Principal Transport and Development Planner | Ashford and Shepway | Highways and Transportation | Kent County Council | Ashford Highway Depot, 4 Javelin Way, Henwood Industrial Estate, Ashford, Kent, TN24 8AD | 03000 41 81 81 | www.kent.gov.uk

From: Longman, Phillip <Phillip.Longman@arcadis.com>
Sent: 12 July 2018 13:15
To: Finch, Colin - GT HTW <colin.finch@kent.gov.uk>; James.Hammond@folkestone-hythe.gov.uk; Hogben, Matt - GT HTW <Matt.Hogben@kent.gov.uk>; Benge, Sally - GT HTW <sally.benge@kent.gov.uk>
Cc: Kearney, Rebecca <rebecca.kearney@arcadis.com>; Collins, Chad <Chad.Collins@arcadis.com>; Maria Rosa Gallego <MariaRosa.Gallego@arcadis.com>
Subject: Otterpool Park Canterbury Trip Distribution Assessment

Dear All

Following the request from Canterbury City Council to consider the impact of Otterpool Park on the City, I have extended our vehicle trip distribution model to include Canterbury in more detail. Previously, Canterbury was included in our distribution model as a single zone, which did not provide the vehicle routing of trips in enough detail to consider impact on individual junctions in Canterbury. We have now included Canterbury in our distribution model as 23 individual zones. The zones have been chosen by generating clusters of Lower Level Super

Output Areas, as defined in Census 2011, according to the likely vehicle routing to each cluster. The attached spreadsheet shows the location of the centre of each zone in the sheet called "GM Zone Centres".

The 23 zones have been included in our three gravity models (one for incoming commuting trips, one for outgoing commuting trips and one for residential trips for non-work purposes), enabling us to determine the number of vehicle trips expected to be generated by the Otterpool Park development to/from each zone. The routes vehicles would take between each zone and Otterpool Park were determined using the vehicle routing tool on Google Maps.

This method of vehicle trip distribution is the method agreed with KCC, Folkstone & Hythe DC and Highways England for all other zones within our assessment area, including Ashford and Folkstone for which it had been necessary to consider likely vehicle routing in a similar level of detail.

You sent us a junction plan taken from the South Canterbury application (shown in sheet "Canterbury Junctions" in the spreadsheet) that identifies 11 existing junctions. The spreadsheet shows the distribution of Otterpool Park vehicle trips through these junctions for the AM and PM peak (sheets "AM Peak Devt Flows" and "PM Peak Devt Flows"). These flows are for full occupation of Otterpool Park at the end year (2044) of our main assessment.

We then extracted future base flows from the Mountfield Park Transport Assessment (sheet "2031 baseline"). These are the 2031 Base + Development flows for 4,000 homes + 45,000sqm commercial space. Sheets "2031 AM Base" and "2031 PM Base" show these trips on our network. We then compared our 2044 development trips to the 2031 baseline trips and calculated a percentage flow increase on each arm of each junction (sheets "Future AM %" and "Future PM %").

Our development flows through the junctions are low and the percentage flow increases range from less than 1% to up to 5%. As we are comparing 2044 development flows against a 2031 baseline, I would expect the flow increase against a 2044 baseline to be even lower.

I would be very grateful if you could review this information and let me know your thoughts on the requirement for further testing of these junctions in the Otterpool Park Transport Assessment.

Kind regards,

Phil

Phillip Longman
Associate Technical Director
Transport Planning & Urban Design

Phillip.Longman@arcadis.com
Arcadis Consulting (UK Limited)
Bernard Weatherill House, 8 Mint Walk, Croydon CR0 1EA

T: 020 3014 9100
www.arcadis.com



Be green, leave it on the screen.



Arcadis Consulting (UK) Limited is a private limited company registered in England & Wales (registered number 02212959). Arcadis House, 34 York Way, London, N1 9AB. Part of the Arcadis Group of Companies along with other entities in the UK.

This email and any files transmitted with it are the property of Arcadis and its affiliates. All rights, including without limitation copyright, are reserved. This email contains information that may be confidential and may also be privileged. It is for the exclusive use of the intended recipient(s). If you are not an intended recipient, please note that any form of distribution, copying or use of this communication or the information in it is strictly prohibited and may be unlawful. If you have received this communication in error, please return it to the sender and then delete the email and destroy any copies of it. While reasonable precautions have been taken to ensure that no software or viruses are present in our emails, we cannot guarantee that this email or any attachment is virus free or has not been intercepted or changed. Any opinions or other information in this email that do not relate to the official business of Arcadis are neither given nor endorsed by it.

APPENDIX B

Vehicle Traffic Survey Data Provided by Folkstone & Hythe District Council

Classified turning counts	
1	B2067 Aldington Road / B2067 Otterpool Lane
2	Aldington Road / Stone Street
3	Aldington Road / Lypne Hill
4	A20 Ashford Road / B2067 Otterpool Lane
5	A20 Ashford Road / Swan Lane
6	A20 Ashford Road / Stone Street / Hythe Road
7	A20 roundabout
8	M20 / A20 / B2068
9	A20 Ashford Road / Sandling Road
10	A260 Canterbury Road / Alkham Valley Road
11	White Horse Hill / A20 EB slips / A260 / A260 Spitfire Way
12	A20 WB slips / Alkham Valley Road
13	M20 WB off slip / A259 Churchill Avenue / A2034 Cherry Garden Avenue / M20 WB on slip / A20 Castle Hill Bridge
14	Eurotunnel EB slip road (Eurotunnel entry flow)
15	Eurotunnel WB slip road (Eurotunnel exit flow)
16	A20 Cheriton Interchange / B2064 Cheriton High Street
17	M20 J12
Classified link counts	
1	A20 Ashford rd (Cheriton It)
2	A20 (N of Sadling) E
3	A20 (N of Sadling) W
4	Stone Street N
5	Stone Street S
6	Aldington Road W
7	Aldington Road E
8	B2067 Aldington Road W
9	B2067 Aldington Road E
10	A20 Barron Hill N
11	A20 Barron Hill S
12	A20 Ashford rd (W Sellindge)
13	Hythe Road W
14	Hythe Road E
15	M20 J13 EB
16	M20 J13 WB
17	B2064 Cheriton App N
18	B2064 Cheriton App S
19	M20 (W OF J11)
20	M20 (N of Sandling)

Vehicle Traffic Survey Data Provided by Corinthian Mountfield Ltd

Classified link counts	
1	Nackington Road
2	Old Dover Road

APPENDIX C

Vehicle Traffic Survey Data Collected July 2017

M20 J10- signalised roundabout- full OD (including underpass)
Ashford Rd (A20)/ Stone Hill- priority- turning count
Ashford Rd (A20)/ Station Rd/ Church Rd- priority- turning counts
Hythe Rd (A20)/ Meersham- priority- turning counts
Hythe Rd (A20)/ The Street- priority- turning counts (2 junctions A and B)
A20 Ashford Rd/ A261 Hythe Rd/Stone St- priority- turning counts
A261 London Rd/ Barrak Hill- priority- turning counts
A259/ Dymchurch Rd/ Military Rd gyratory- signalised- full OD
A259 Prospect Rd/ A259 Seabrook Rd/ Station Rd/ High St- priority roundabout- full OD
A20 Ashford Rd/ A20 J11 offslip- priority- turning counts
M20 J11A- priority full OD required including all on/ offslips and M20 overpass
M20 J12- priority full OD required including all on/ offslips and M20 overpass
M20 J13- priority full OD required including all on/ offslips and M20 overpass
A20 Ashford Rd/ Stone Street- priority- turning counts
M20 J9- signalised full OD including all on/ offslips and M20 overpass
B2064 Cheriton High street / B2063 Risborough Lane – priority – turning counts
B2064 Cheriton High street / A2034 Cherry Garden avenue – priority – turning counts
A259 Prospect Road / Stade Street – priority – turning counts

APPENDIX D

ANPR Data Collected July 2017

ANPR data collection locations marked as ▲

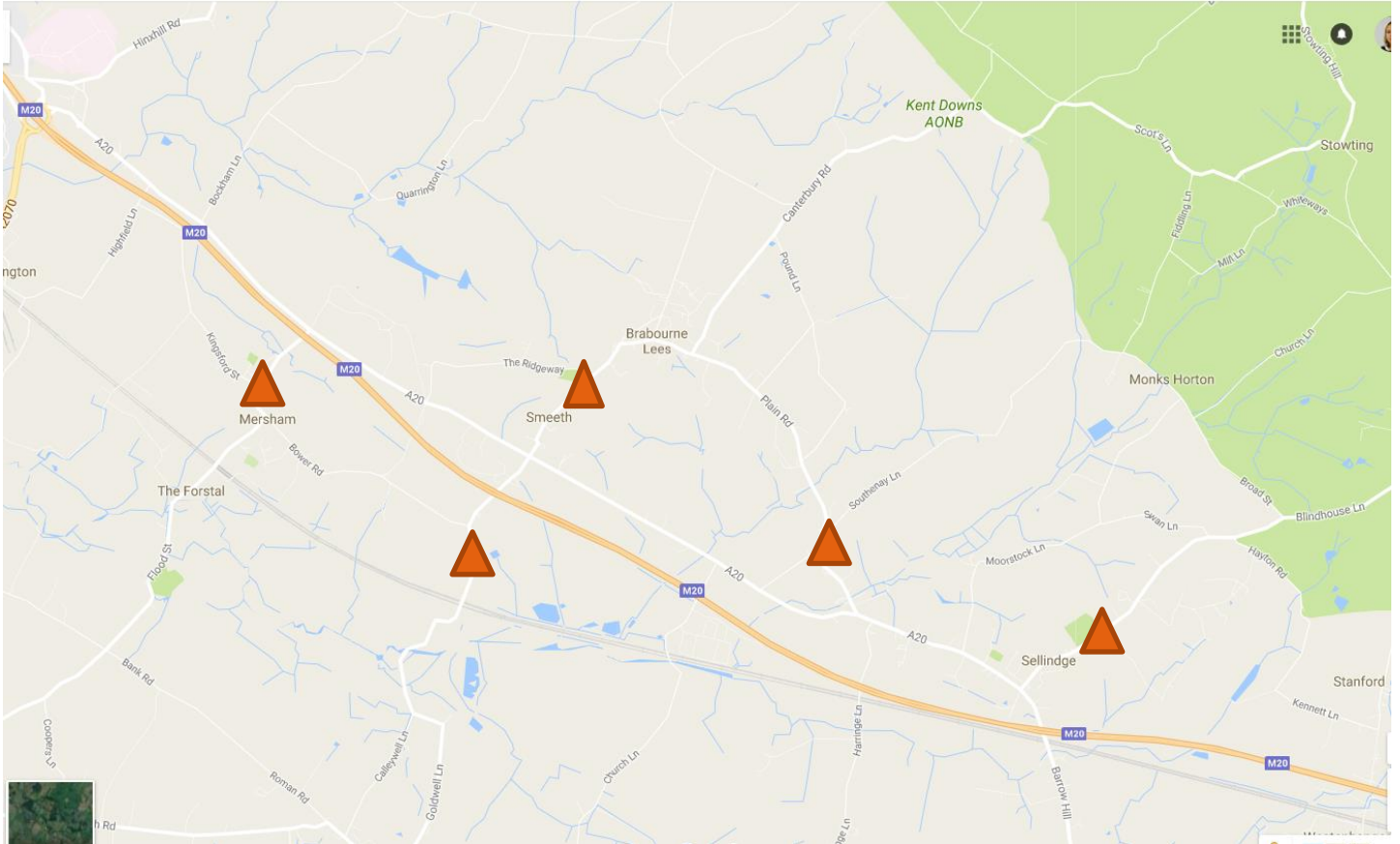

Otterpool Park Transport Assessment Scoping Report

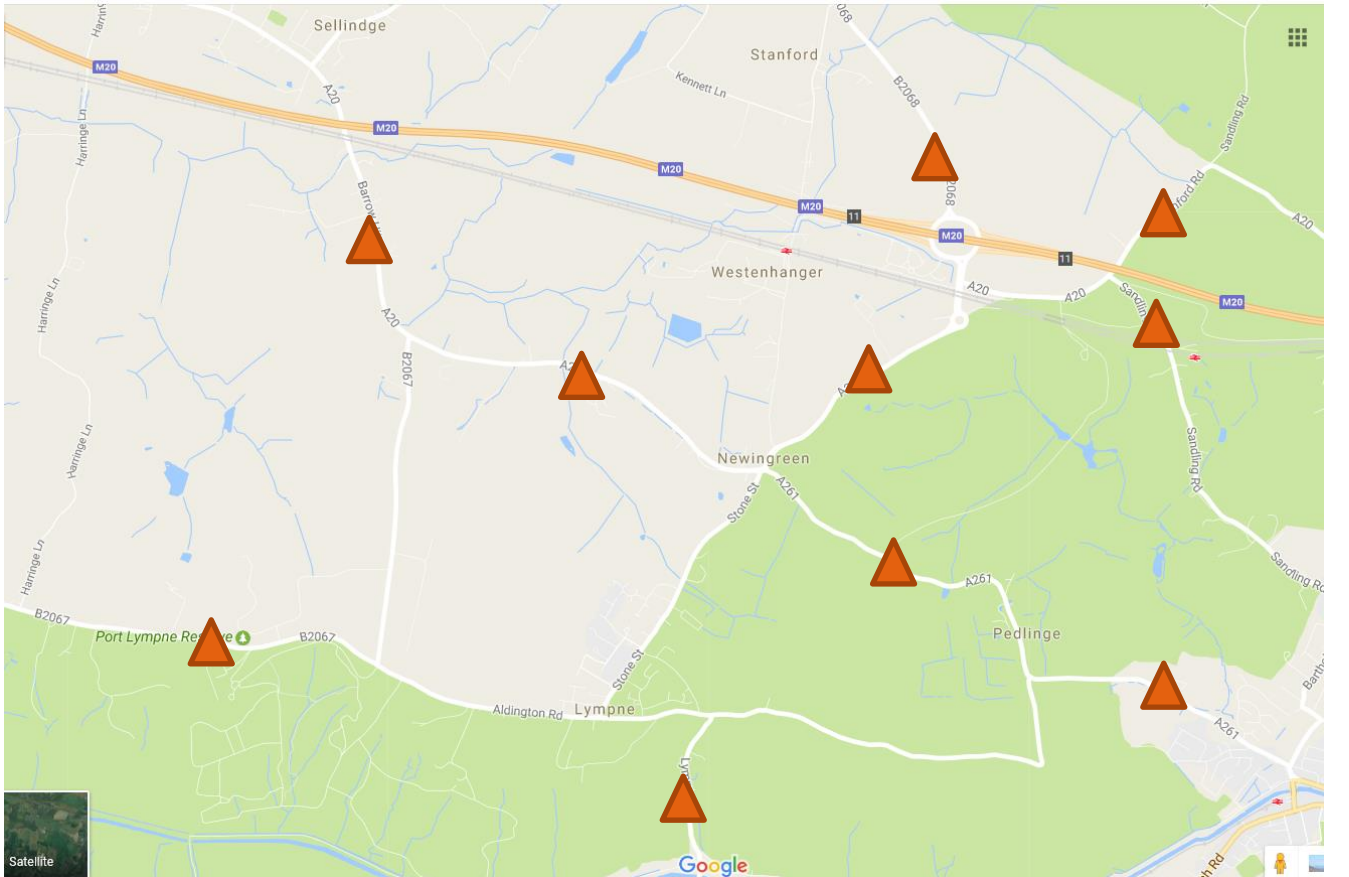
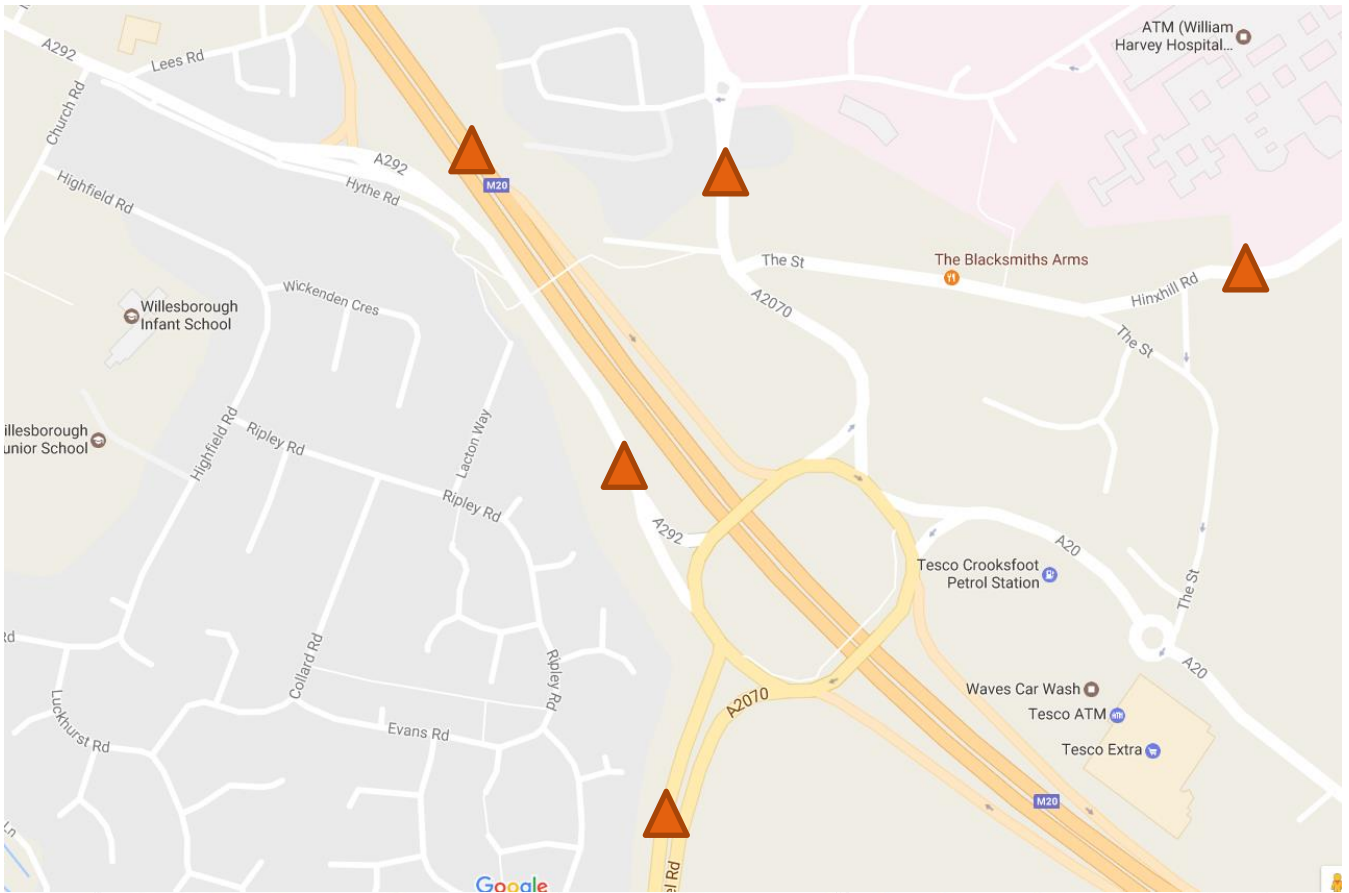

Otterpool Park Transport Assessment Scoping Report



Otterpool Park
Transport Assessment Scoping Report
APPENDIX E

Local Footpaths and Bridleways

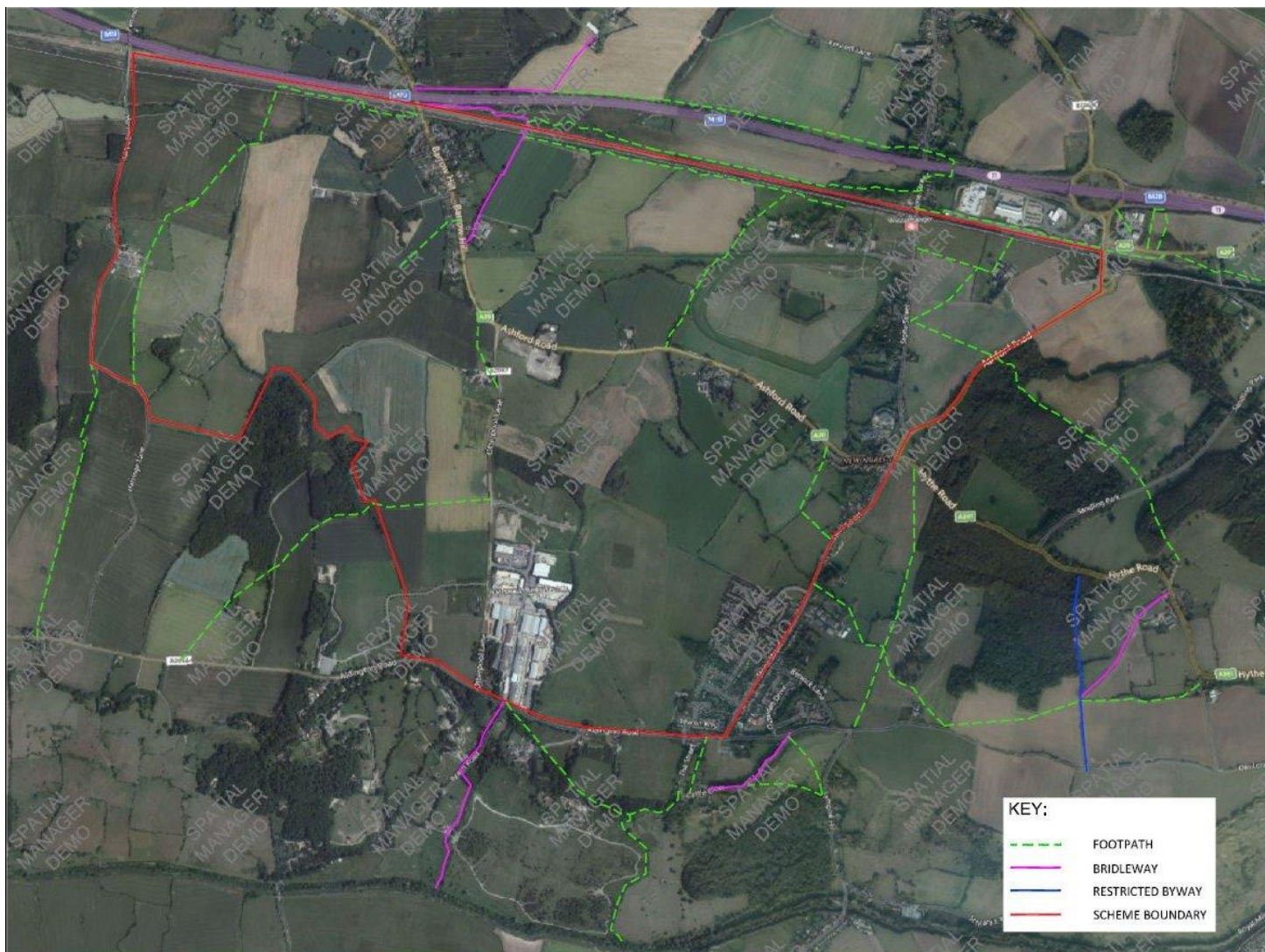

Otterpool Park
 Transport Assessment Scoping Report
APPENDIX F

Extent of VISUM model

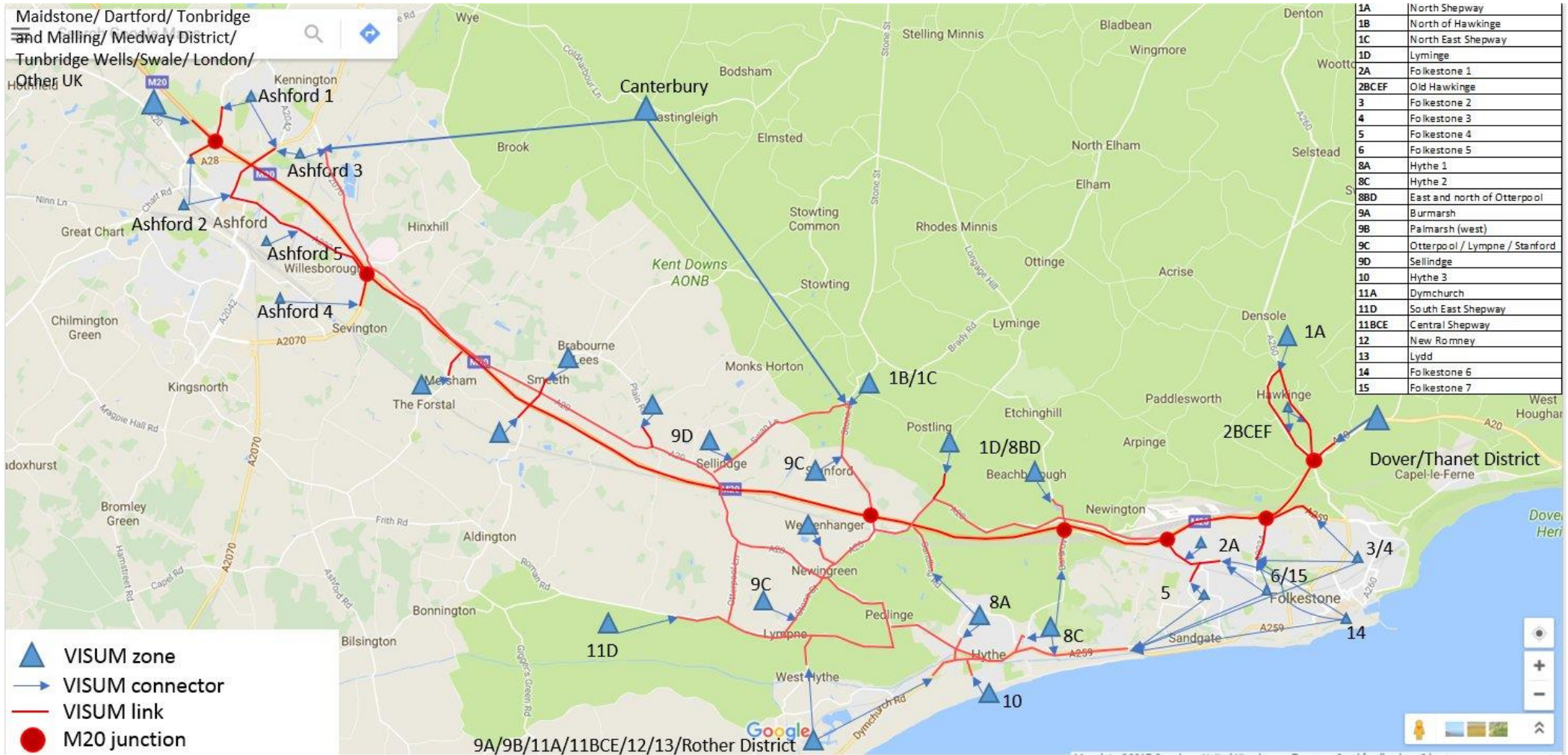

Otterpool Park
Transport Assessment Scoping Report
Extent of VISSIM model

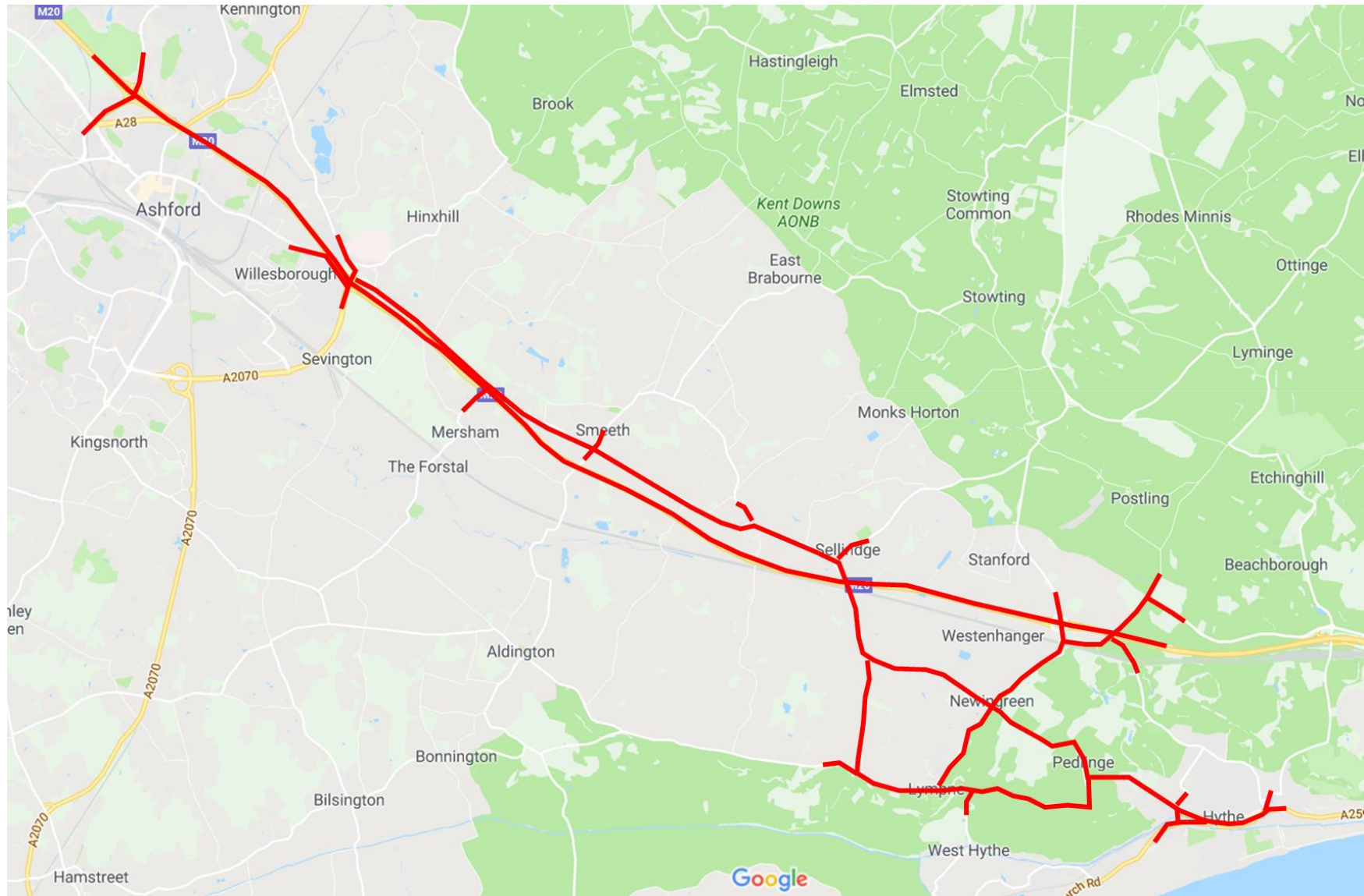

Arcadis Consulting (UK) Limited

Arcadis House
34 York Way
London N1 9AB
United Kingdom
T: +44 (0)20 7812 2000

[arcadis.com](https://www.arcadis.com)



**APPENDIX B – Canterbury Modelling and Data Validation
Report**

OTTERPOOL PARK

Operational Modelling Validation Report: Canterbury

SEPTEMBER 2018

Incorporating

EC HARRIS
BUILT ASSET
CONSULTANCY



CONTENTS

1	INTRODUCTION	1
1.1	Background	1
1.2	Purpose of this Note	1
1.3	Study Area	2
1.4	Road Network	3
1.4.1	Old Dover Road	4
1.4.2	St Lawrence Road	4
1.4.3	The Drive	4
1.4.4	Nackington Road	4
2	BASELINE CONDITIONS	5
2.1	Introduction	5
2.2	2014 Traffic Surveys	5
2.3	2014 Base Traffic Model Results	9
2.4	2018 Baseline Conditions	11
3	SUMMARY AND CONCLUSION	18
3.1	Summary	18
3.2	Conclusion	18

TABLES

Table 1	Junction Name and Type	2
Table 2	2014 AM Peak Hour Origin -Destination Matrix (PCUs)	6
Table 3	2014 PM Peak Hour Origin -Destination Matrix (PCUs)	7
Table 4	Observed Queue Results	9
Table 5	2014 AM Base Traffic Model and Observed Results	10
Table 6	2014 PM Base Traffic Model and Observed Results	10
Table 7	Comparison between 2014 and 2018 traffic flow data	14

APPENDICES

APPENDIX A

Mountfield Park Raw Traffic Data

APPENDIX B

Signal Configuration Plans

APPENDIX C

2018 Base LinSig Model Outputs

1 Introduction

1.1 Background

Arcadis Consulting (UK) Limited was appointed to develop a masterplan and planning submission in respect of the proposed development called Otterpool Park.

In December 2016, a Feasibility and Capacity Study undertaken as part of Stage 1 of the masterplanning process included a high-level assessment of the capacity of the M20 Junction 11, investigating the existing operation of the junction and testing a number of development scenarios using trip forecasts from a high-level trip generation calculation exercise based on vehicle trip rates provided by Shepway District Council.

Following the initial high-level capacity assessment in January 2017, a Trip Model was developed to calculate the number of trips generated by the site, the mode of travel in which the trips will occur and the spatial distribution of the trips. The masterplan has been developed further and a planning application is due to be submitted in 2018.

Scoping discussions with Kent County Council (KCC), Folkstone & Hythe District Council (F&HDC) and Highways England to agree the transport requirements for the planning application were conducted between May 2017 and June 2018. A Transport Assessment scoping note¹ containing the proposed modelling study area was issued in August 2017. Technical notes describing the proposed trip generation² and distribution³ method were submitted in May 2017 and July 2017 respectively. These reports will be updated prior to planning application submission.

In June 2016, Canterbury City Council provided scoping opinion to F&HDC requesting further analysis of the effect of the Otterpool Park proposals in Canterbury. Following further scoping discussion with KCC, it was agreed that traffic modelling of the following two signalised junctions would be required:

- a) Old Dover Road / The Drive / St Lawrence Road; and
- b) Old Dover Road / Nackington Road.

1.2 Purpose of this Note

The purpose of this note is to provide a high-level assessment of the existing conditions at the site and develop a suitable 2018 base model for assessing the potential impacts of Otterpool Park development traffic on the road network at this location.

A calibrated and validated base model for the Old Dover Road/ The Drive junction to Old Dover Road / Nackington Road junction was developed as part of the 2014 Mountfield Park Transport Assessment and has been used as the basis for this assessment. This note outlines how a new 2018 baseline year was established using the traffic conditions and base junction modelling undertaken in 2014 and provides an assessment of 2018 traffic conditions and flows.

¹ *Otterpool Park Garden Settlement Transport Assessment Scoping Report (August 2017)*

² *Otterpool Park Garden Settlement Trip Generation Calculation Method Technical Note (May 2017)*

³ *Otterpool Park Garden Settlement Method for the Distribution of External Vehicle Trips (July 2017)*

1.3 Study Area

The Old Dover Road/The Drive junction is situated next to Canterbury Cricket Club (a mile south-east of Canterbury city). There is a large proportion of residential housing along with shops and services supplying the local area. The locations of the two junctions are shown in Figure 1. Table 1 presents the type of each junction.

Figure 1 Site Location



Table 1 Junction Name and Type

No.	Junction	Type
Junction 1	Old Dover Road / The Drive / St Lawrence Road	Signalised Crossroads
Junction 2	Old Dover / Nackington Road	Signalised T Junction

1.4 Road Network

The Old Dover Road / The Drive / St Lawrence Road junction is a four-arm signalised crossroad that is linked to the three arm signalised Old Dover Road / Nackington Road T-junction via Old Dover Road. The road network shown Figure 2.

Figure 2 Road Network

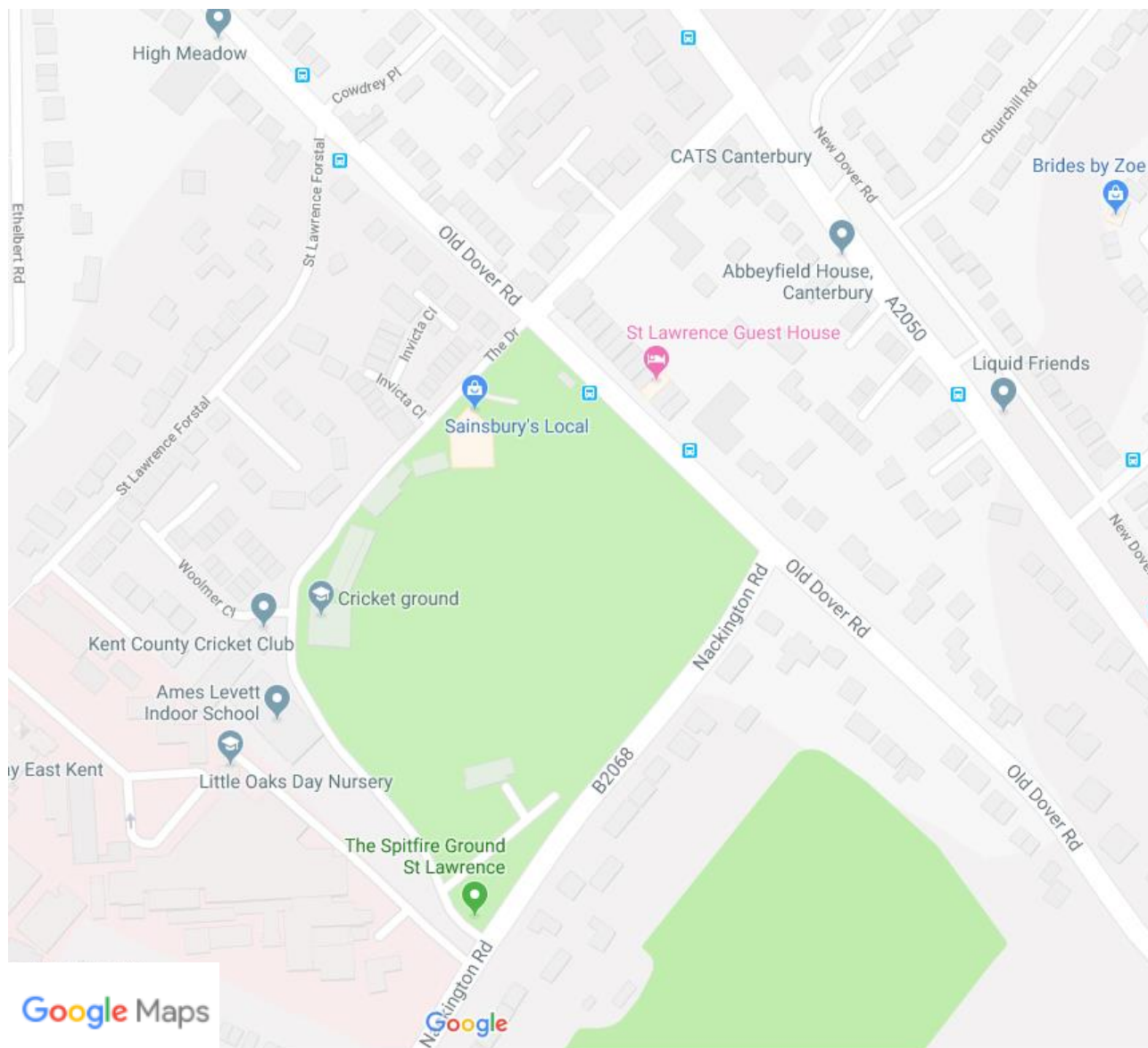

1.4.1 Old Dover Road

Old Dover Road runs from the Rhoadus Town/Upper Bridge Street roundabout on the south east of Canterbury Town Centre to the Old Gate Inn roundabout with New Dover Road to the south east of Canterbury. It is approximately 2km long and operates as a mixture of UAP3 and UAP4 link road with traffic calming between the Old Gate Inn roundabout to the south east and the junction with Nackington Road.

In the vicinity of the study site, Old Dover Road runs northwest – southeast and is the connecting link arm between the Old Dover Road / The Drive / St Lawrence Road junction and the Old Dover Road / Nackington Road junction. The Old Dover Road northwest approach to the Old Dover Road / The Drive junction has a 3.4m single lane with an advanced stopline for cyclists. Similarly, the southeast approach to the Old Dover Road / The Drive junction is a single lane approach with an advanced stopline for cyclists but with an approximate lane width of 3m. A straight-over signalised pedestrian crossing operates on the southeast approach with a crossing distance of approximately 10m.

The 170m section of Old Dover Road between the Old Dover Road/ The Drive / St Lawrence Road and Old Dover Road / Nackington Road junctions is slightly wider with a two-way carriageway width of approximately 9m. This is to accommodate on street parking on the northern side of the carriageway. There are also bus stops in both directions on Old Dover Road between the two junctions.

Southbound on approach to the Old Dover Road / Nackington Road junction, Old Dover Road flares to two lanes. This provides a 60m right-turn lane into Nackington Road that operates on an indicative right-turn signal. South of the Nackington Road junction there are traffic calming measures and the centre line on Old Dover Road is removed.

1.4.2 St Lawrence Road

St Lawrence Road runs between New Dover and Old Dover Road in a north east – south west direction. It is approximately 162m long with double yellow lines on both sides of the carriageway throughout its length except for a small amount of permit holder parking bays on the northern side of the carriageway. The carriageway is approximately 6m wide with single 3m lanes running in each direction. It has a single lane approach to the Old Dover Road junction with an advanced stopline for cyclists.

1.4.3 The Drive

The Drive is a narrow access road to residential cul de sacs and the Kent County Cricket Club. It has a single lane approach to the Old Dover Road / The Drive / St Lawrence Road junction, approximately 2.2m wide, with an advanced stopline for cyclists.

1.4.4 Nackington Road

Nackington Road is a key link road connecting Canterbury with villages and towns to the south. It is a two-way single lane carriageway with approximately 3m wide lanes. On approach to the junction with Old Dover Road it widens to two lanes to provide a short 30m right-turn flare with an advanced stopline for cyclists.

2 Baseline Conditions

2.1 Introduction

As part of the Mountfield Park planning application a technical note detailing the 2014 baseline traffic survey results was included. The raw traffic data collected for the site is provided as part of the appendices and includes data for both the Old Dover Road / The Drive / St Lawrence Road and Old Dover / Nackington Road junctions.

It was agreed with the KCC Highways Team that 2014 survey data collected as part of the Mountfield Park Transport Assessment (TA) could be used for the Otterpool Park assessment provided that they are validated against 2018 count data. In this Chapter, we present and compare the 2014 and 2018 traffic flow data.

2.2 2014 Traffic Surveys

The raw survey data from the Mountfield Park TA included classified turning counts for the Old Dover Road / The Drive / St Lawrence Road and Old Dover / Nackington Road junctions (see Appendix A). This data was extracted and factored to obtain turning volumes in Passenger Car Units (PCUs) which is approximately a single car length of 5.75m. These turning counts were used as the 2014 base traffic flow demands. The AM and PM peak hours were 08:00 – 09:00 hours and 17:00 – 18:00 hours respectively. Table 2 and Flows in red indicate key movements.

Table 3 present the traffic flows in PCUs on each of the arms during the AM peak and PM peak hours.

Table 2 2014 AM Peak Hour Origin -Destination Matrix (PCUs)

Approach From	Travelling To					Total
	A – St Lawrence Road	B – Old Dover Road South	C – Nackington Road	D – The Drive	E – Old Dover Road North	
A – St Lawrence Road	0	40	102	26	122	290
B – Old Dover Road South	43	0	71	6	162	282
C – Nackington Road	102	102	0	16	316	536
D – The Drive	15	9	22	0	32	78
E – Old Dover Road North	53	70	180	25	0	328
Total	213	221	375	73	632	1514

Flows in red indicate key movements.

Table 3 2014 PM Peak Hour Origin -Destination Matrix (PCUs)

Approach From	Travelling To					Total
	A – St Lawrence Road	B – Old Dover Road South	C – Nackington Road	D – The Drive	E – Old Dover Road North	
A – St Lawrence Road	0	62	104	14	25	205
B – Old Dover Road South	36	0	105	20	92	253
C – Nackington Road	56	100	0	33	134	323
D – The Drive	34	21	33	0	40	128
E – Old Dover Road North	68	155	271	46	0	540
Total	194	338	513	113	291	1449

Flows in red indicate key movements.

Figure 3 provides a visual representation of the predominant traffic flows recorded at the junctions. It shows that the predominant traffic flows were as follows:

- Old Dover Road North to Nackington Road – AM and PM peak hours;
- Nackington Road to Old Dover Road North – AM and PM peak hours;
- Old Dover Road South to Old Dover Road North – AM peak hour; and
- Old Dover Road North to Old Dover Road South – PM peak hour.

The key movements indicate that there is a tidal flow pattern along Old Dover Road with heavier northbound movements in the AM peak hour (towards Canterbury) and southbound movements in the PM peak hour. Movements to and from Nackington Road and Old Dover North were heavy in both the AM and PM peak hours.

Figure 3 Key Traffic Flow Movements



As part of the traffic surveys, 15-minute queue data was also collected at the two junctions. The observed data is presented in Table 4. The data indicates that the longest queues average and maximum queues in the AM peak hour formed on Nackington Road. Long queues also formed on the Old Dover South and North approaches. In the PM peak hour, the longest queues formed on Old Dover North, Nackington Drive and The Drive.

Table 4 Observed Queue Results

Approach		Queue Lengths			
		AM Peak Hour		PM peak Hour	
		Average	Maximum	Average	Maximum
A	St Lawrence Road	5	5	4	5
B	Old Dover Road South	9	10	6	8
C	Nackington Road	14	17	11	15
D	The Drive	3	4	9	10
E	Old Dover Road North	9	14	13	16

2.3 2014 Base Traffic Model Results

A calibrated and validated base model for the Old Dover Road / The Drive / St Lawrence Road junction to Old Dover / Nackington Road junction was developed as part of the Mountfield Park TA. Using the base LinSig model outputs from the TA a 2014 base model for the Old Dover Road / The Drive / St Lawrence Road and Old Dover / Nackington Road junctions was developed for the Otterpool Park assessment. This model retained the network layout, saturation flows and signal coordination which had previously been approved. Signal timing sheets, signal layout drawings, and any other supplementary signal data provided by the Local Authority were checked and used to input the phases and associated phase delays, phase minimums and intergreen matrices. These are included in Appendix B. It has been assumed that since no network changes have been implemented at this location since 2014 and therefore that the model provides a reasonable representation of existing network conditions. Table 5 and Table 6 provide a comparison of the base model Degree of Saturation (DoS) and Mean Maximum Queue length (MMQ) results and observed average and maximum queue lengths. Full model outputs are provided in Appendix C.

The base model results indicate that the network is fully saturated, particularly in the AM peak hour. The model indicates that four approaches, St Lawrence Road, Old Dover Road South, Nackington Road and Old Dover Road North are operating above practical capacity in the 2014 baseline conditions all with a DoS above 90%. The model also predicts long sustained queues on these approaches, which is in line with the observed average and maximum queue data. However, it should be noted that the observed average and maximum queue lengths on St Lawrence Road were lower than those predicted in the base LinSig model. A comparison with typical peak hour traffic using the Google Traffic application on Google Maps, shown in Figure 4, indicates that the base model is consistent with current typical peak hour traffic conditions. The entire network is shown in amber with red on the St Lawrence Road, Old Dover Road South and Nackington Road approaches. This indicates heavy congestion on the surrounding road network and the approaches identified in the base LinSig model.

The base model results for the PM peak hour also indicate that the network is operating at capacity, with one approach, Old Dover North, predicted to be operating above practical capacity with a DoS of 100.7%. The modelled MMQ for each of the approaches are consistent with those observed on site with the longest queues forming on Old Dover North.

Table 5 2014 AM Base Traffic Model and Observed Results

Approach		AM Peak Hour			
		Modelled		Observed	
		DoS (%)	Mean Max Queue (PCU)	Average Queue (Vehicles)	Max Queue (Vehicles)
A	St Lawrence Road	99	16	5	5
B	Old Dover Road South	64	9	9	11
C	Nackington Road	94	9	14	17
D	The Drive	49	3	3	4
E	Old Dover Road North	95	15	9	14
-	Old Dover Internal Link Northbound	98	27	9	10
-	Old Dover Internal Link Southbound	64	9	7	8

Table 6 2014 PM Base Traffic Model and Observed Results

Approach		PM Peak Hour			
		Modelled		Observed	
		DoS (%)	Mean Max Queue (PCU)	Average Queue (Vehicles)	Max Queue (Vehicles)
A	St Lawrence Road	77	8	4	5
B	Old Dover Road South	85	10	6	7
C	Nackington Road	78	6	11	15
D	The Drive	89	7	9	10
E	Old Dover Road North	101	29	13	16
-	Old Dover Internal Link Northbound	82	6	6	8
-	Old Dover Internal Link Southbound	68	6	8	10

Figure 4 Google Traffic Typical Traffic conditions: AM Peak Hour

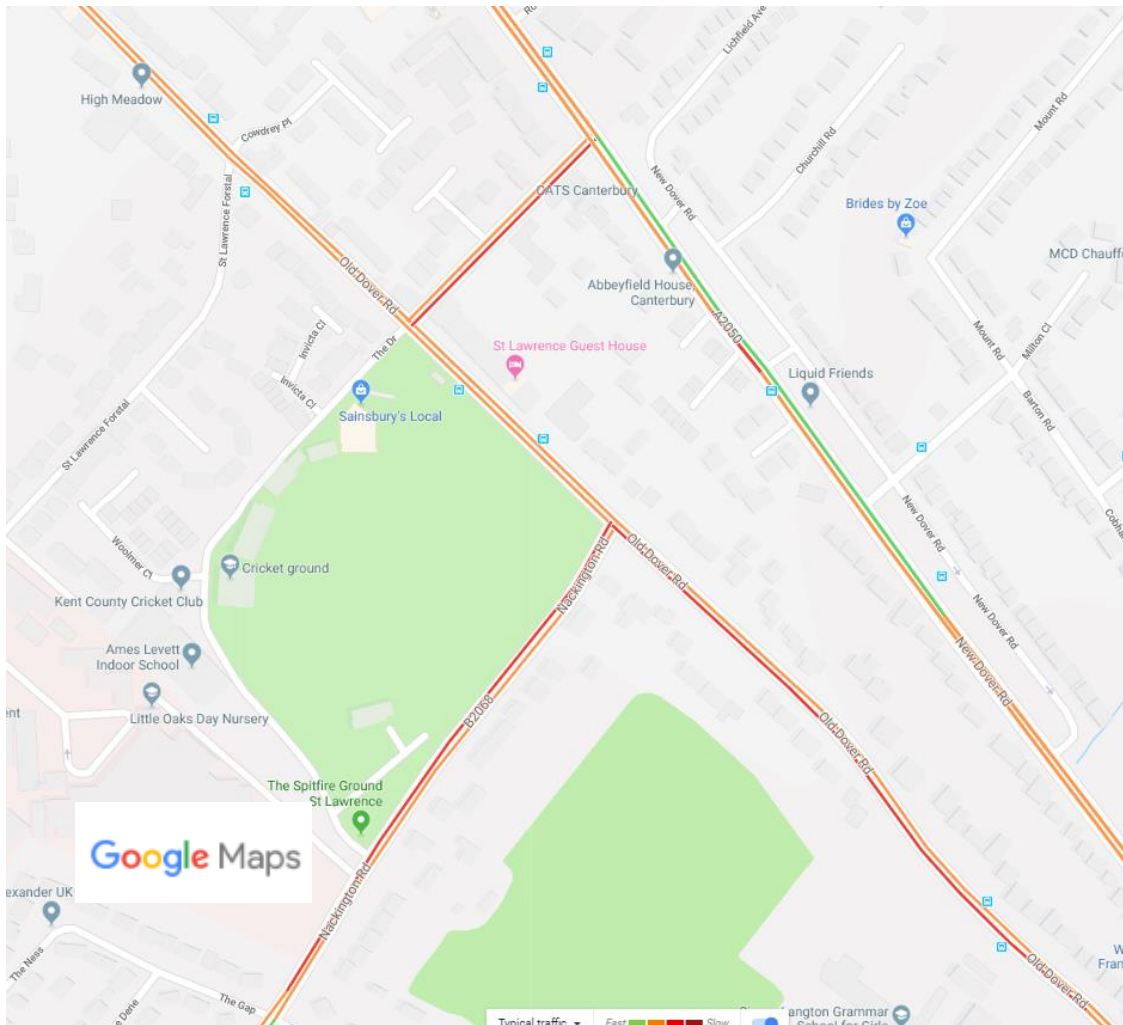

2.4 2018 Baseline Conditions

Since the traffic data used in the 2014 Mountfield Park TA is greater than 3 years old, KCC requested that it should be compared with 2018 traffic count data and adjusted accordingly to establish a new 2018 baseline for the network.

Automated Traffic Count (ATC) data was collected in March 2018 at the locations shown in Figure 5. Whilst only two of the five entrances to the network were covered by the 2018 ATCs, these are considered to be the two critical entrances and exits to the network. The ATC on Old Dover Road captures all of the traffic routing to and from the centre of Canterbury. The ATC on Nackington Road captures strategic traffic from south of Canterbury which is where the proposed Otterpool development is located. The ATCs are close enough to the junctions to assume that there would not be a significant leakage in network traffic and would therefore provide a robust method to assess network traffic growth.

Figure 5 2018 ATC Locations



Figure 6 shows a comparison of the rolling hour traffic flow profiles for each movement for each weekday as well as the weekday average. The data indicates that daily traffic profiles for each movement are consistent across each of the observed weekdays. The traffic flow profiles for Old Dover Road Northbound and Southbound show a tidal movement in the AM and PM peak hours with heavier flows northbound in the AM and southbound in the PM. As the flow profiles across each of the weekdays are similar, the average flow across the weekdays has been used for the purposes of this assessment.

Otterpool Park
Operational Modelling Validation Report

Figure 6 2018 ATC Rolling Hour Traffic Flow Profiles (PCUs)

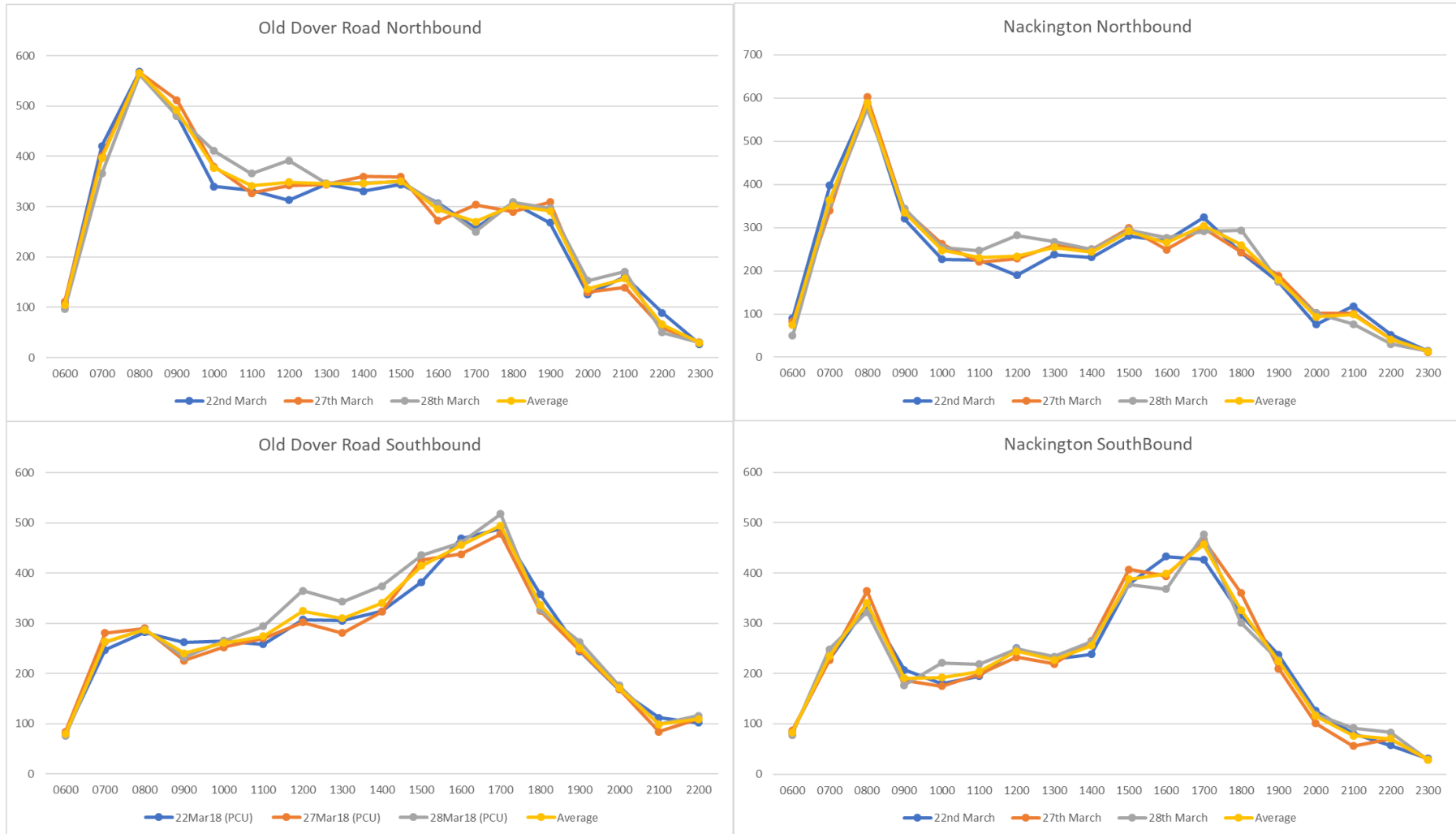
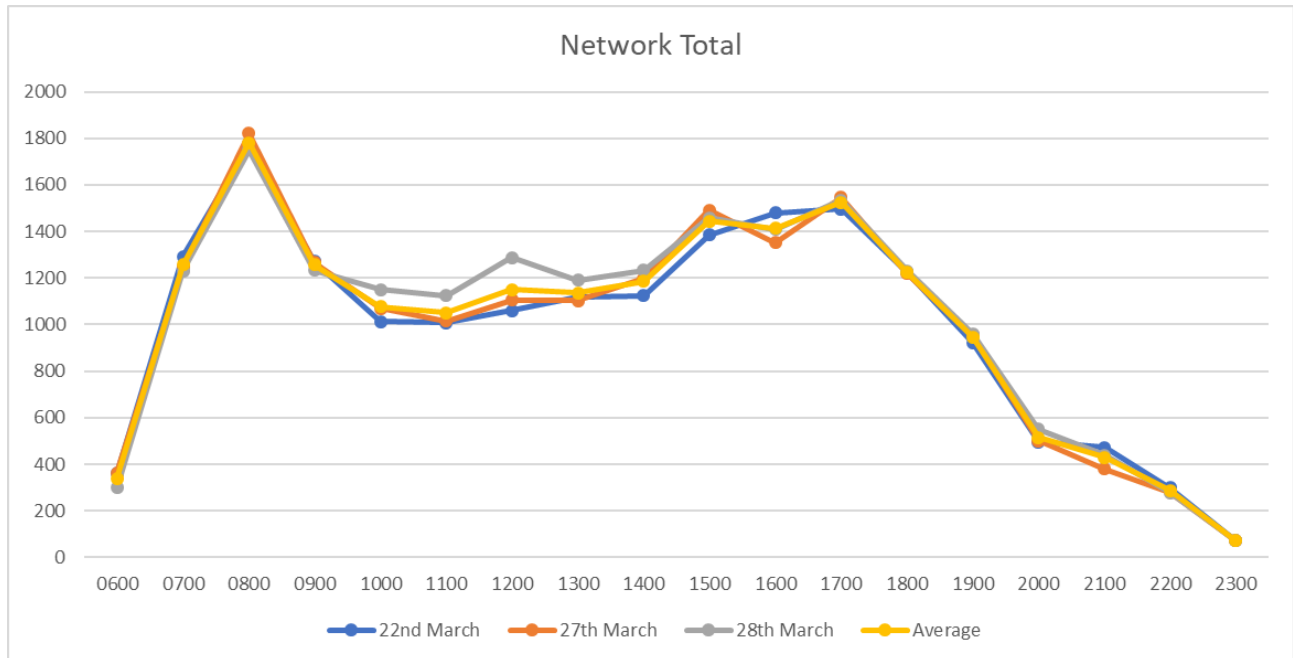

Figure 7 shows the network 'rolling hour' total flow profile for each weekday. These are also consistent across weekdays and indicate the peak hours are still 08:00 – 09:00 and 17:00 – 18:00 for the AM and PM peak hours respectively.

Figure 7 2018 Rolling Hour Network Total Traffic Flow Profiles (PCUs)



This comparison is shown in Table 7.

Table 7 Comparison between 2014 and 2018 traffic flow data

Direction	AM Peak Hour				PM Peak Hour			
	Traffic Flow (PCU)		Flow Difference		Traffic Flow (PCU)		Flow Difference	
	2014	2018	Vehicles	%	2014	2018	Vehicles	%
Nackington Road SB	376	340	-36	-9.6%	512	456	-55	-10.8%
Nackington Road NB	535	589	54	10.1%	317	305	-13	-3.9%
Old Dover Road SB	329	288	-41	-12.4%	530	518	-12	-2.3%
Old Dover Road NB	631	591	-41	-6.4%	291	277	-14	-4.8%
Total	1871	1808	-63	-3.4%	1650	1556	-94	-5.7%

The data indicates that there has been little change in traffic flows along Old Dover Road and Nackington Road between 2014 and 2018. The results indicate a net decrease in traffic demand of -3.4% and -5.7% in the AM and PM peak hours respectively.

Although a decrease in traffic demand or volume is not typically expected, it reflects the constraints on the network. The network results in the 2014 base LinSig model indicate that the network is fully saturated and

without network improvements additional traffic would not be able to be accommodated through these junctions. It is therefore a reasonable assumption there has been no growth in peak hour traffic flows at this location as there is not enough capacity on the network to accommodate further growth. There may have been an increase in demand in the shoulder peaks either side of the peak hour, however this does not affect the peak hour growth assumptions.

A review of the available annual count data in the vicinity of the site found that one DfT count point was in close proximity to the site. DfT count point ID 26110, shown in

, is located to the south east of the site. The annual count data for 2012 – 2017 for this location was extracted and is presented Figure 8. The data indicates that there was a reduction in yearly flows between 2014 and 2017. This is consistent with the reduction observed between the 2018 ATC data and 2014 junction turning counts.

Figure 8 DfT Count Point 26110 Location

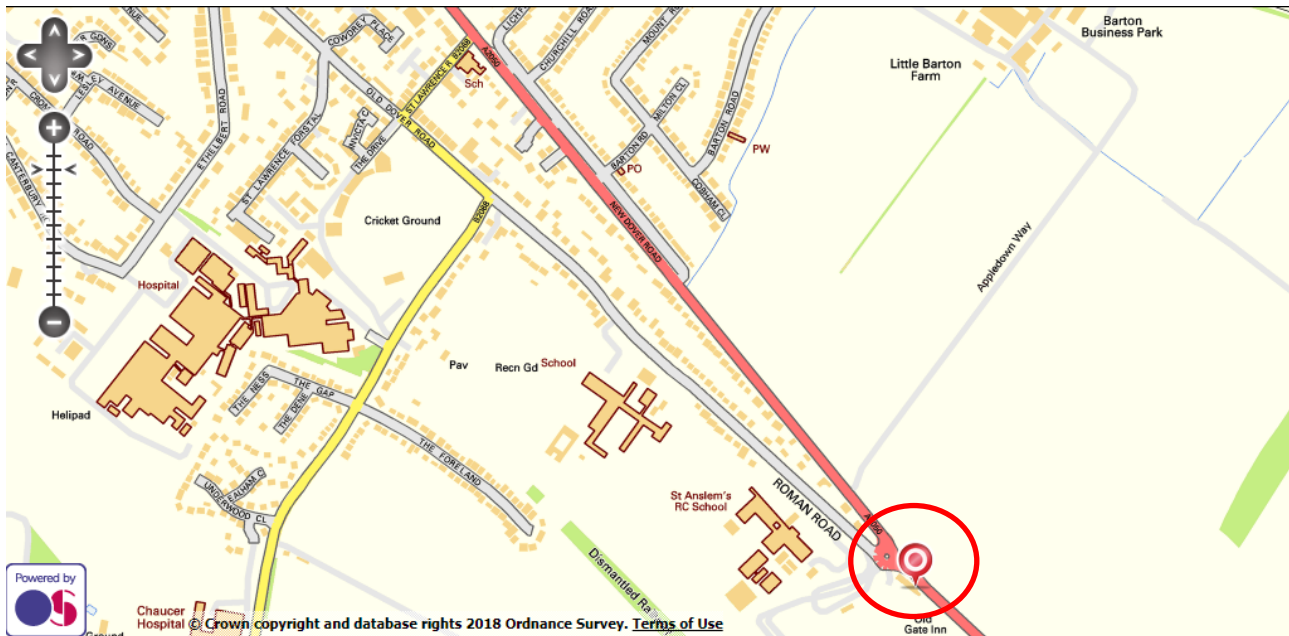
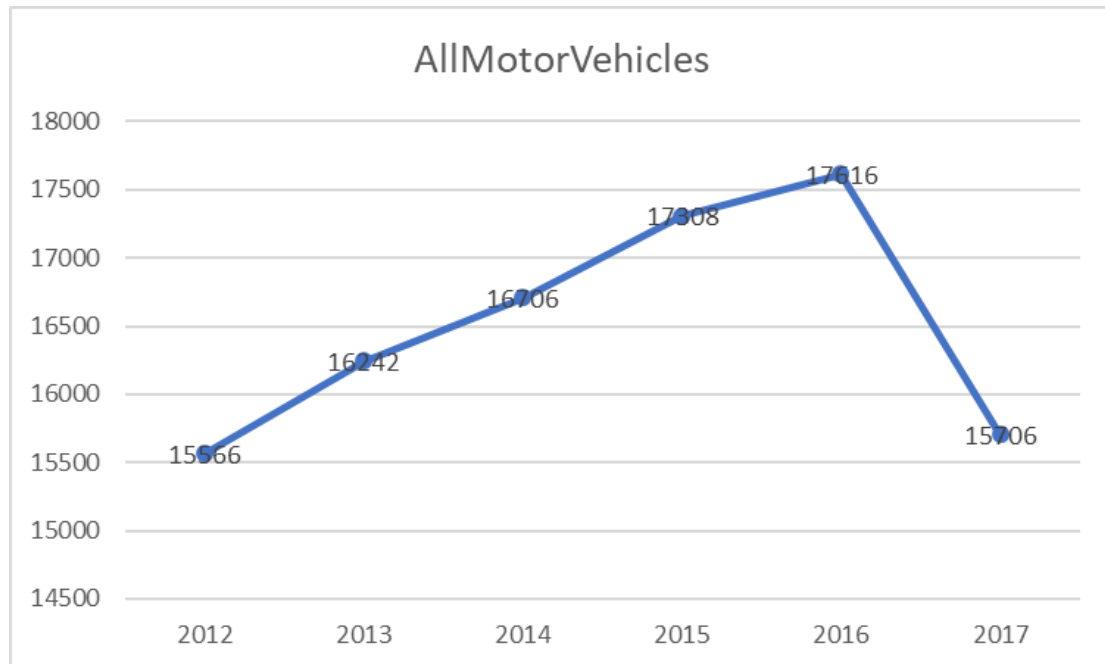

Figure 9 DfT Annual Traffic Flows at Count Point 26110



Therefore, based upon this assessment it is considered that no network traffic growth should be applied to the 2018 baseline and that the 2014 base model and traffic flows are considered a reasonable representation of the existing conditions at the site. It is also considered the worst-case scenario as the 2014 flows are higher than those recorded in 2018.

3 Summary and Conclusion

3.1 Summary

Arcadis Consulting (UK) Limited was appointed to undertake a traffic modelling assessment of the network surrounding Canterbury Cricket Club. Specifically, the Old Dover Road/ The Drive junction to the B2068 Nackington Road junction.

A calibrated and validated base model for the Nackington Road / Old Dover Road T-Junction to Old Dover Road / The Drive / St Lawrence Road junction was developed as part of the Mountfield Park TA. Using the base LinSig model outputs from the TA a 2014 base model for the junctions was developed. This model retained the network layout, saturation flows and signal coordination which had previously been approved.

The base model results indicate that the network is fully saturated, particularly in the AM peak hour. The model indicates that four approaches, St Lawrence Road, Old Dover Road South, B2068 Nackington Road and Old Dover Road North are operating above practical capacity in the 2014 baseline conditions all with a DoS above 90%.

In order to establish a new 2018 baseline for the network, the 2014 traffic count data was compared with 2018 ATC data. The comparison indicated that there has been little change in traffic flows along Old Dover Road and Nackington Road between 2014 and 2018. The results indicate a net decrease in traffic demand of 3.4% and 5.7% in the AM and PM peak hours respectively.

3.2 Conclusion

Based upon this assessment it is considered that no network traffic growth should be applied to the 2018 baseline and that the 2014 base model and traffic flows are considered a representation of the existing conditions at the site and fit to be used for the Otterpool Park assessment work for the Nackington Road / Old Dover Road and Old Dover Road / The Drive / St Lawrence Road junctions.

APPENDIX A

Mountfield Park Raw Traffic Data

JUNCTION Old Dover Road (NORTH) / St Lawrence Road

AM

Old Dover Road (NORTH)

TIME	Left to St Lawrence								Ahead ODR (S)								Right The Drive								Total				
	P/CY	M/C'	CAR	LGV	OGV	OGV	BUS	TOT/PCU	P/CY	M/C'	CAR	LGV	OGV	OGV	BUS	TOT/PCU	P/CY	M/C'	CAR	LGV	OGV	OGV	BUS	TOT/PCU					
800 - 815	0	0	3	1	0	0	0	4	4	1	0	58	1	1	1	2	63	67	0	0	7	2	0	0	0	9	9		
815 - 830	0	0	17	0	0	0	0	17	17	5	2	74	2	0	0	1	79	80	0	0	4	2	0	0	0	6	6		
830 - 845	0	0	21	0	0	0	1	22	23	1	0	45	3	0	0	6	54	62	0	0	4	0	0	0	0	4	4		
845 - 900	0	0	8	1	0	0	0	9	9	0	0	32	7	2	0	0	41	42	2	0	5	1	0	0	0	6	6.4		
Hourly Total	0	0	49	2	0	0	1	52	53	7	2	209	13	3	1	9	237	250	2	0	20	5	0	0	0	25	25	314	329

St Lawrence

TIME	Left								Ahead								Right								Total				
	P/CY	M/C'	CAR	LGV	OGV	OGV	BUS	TOT/PCU	P/CY	M/C'	CAR	LGV	OGV	OGV	BUS	TOT/PCU	P/CY	M/C'	CAR	LGV	OGV	OGV	BUS	TOT/PCU					
800 - 815	0	1	30	3	1	0	0	35	35	0	0	4	0	0	0	0	4	4	0	0	29	0	0	0	0	29	29		
815 - 830	0	0	35	5	1	0	1	42	44	1	0	11	1	0	0	0	12	12	2	0	30	0	0	0	0	30	30		
830 - 845	0	0	32	2	1	0	0	35	36	0	0	3	0	0	0	0	3	3	1	0	28	0	0	0	0	28	28		
845 - 900	1	0	22	1	0	0	2	25	28	0	0	5	2	0	0	0	7	7	0	0	34	0	0	0	0	34	34		
Hourly Total	1	1	119	11	3	0	3	137	142	1	0	23	3	0	0	0	26	26	3	0	121	0	0	0	0	121	122	284	289

Old Dover F

TIME	Left								Ahead								Right								Total				
	P/CY	M/C'	CAR	LGV	OGV	OGV	BUS	TOT/PCU	P/CY	M/C'	CAR	LGV	OGV	OGV	BUS	TOT/PCU	P/CY	M/C'	CAR	LGV	OGV	OGV	BUS	TOT/PCU					
800 - 815	0	0	8	1	0	0	0	9	9	0	2	101	4	0	0	1	108	108	0	0	37	4	0	0	0	41	41		
815 - 830	0	0	4	1	0	0	0	5	5	1	0	80	6	1	0	8	95	106	0	0	28	3	0	0	0	31	31		
830 - 845	0	0	4	0	0	0	0	4	4	0	0	85	5	2	0	5	97	105	0	1	42	2	0	0	1	46	47		
845 - 900	0	0	3	1	0	0	0	4	4	0	0	115	7	1	2	14	139	160	0	0	22	4	0	0	0	26	26		
Hourly Total	0	0	19	3	0	0	0	22	22	1	2	381	22	4	2	28	439	478	0	1	129	13	0	0	1	144	145	605	645

The Drive		Left								Ahead								Right								Total			
TIME		P/CY	M/C'	CAR	LGV	OGV	OGV	BUS	TOT/	PCU	P/CY	M/C'	CAR	LGV	OGV	OGV	BUS	TOT/	PCU	P/CY	M/C'	CAR	LGV	OGV	OGV	BUS	TOT/	PCU	Total
800 -	815	0	0	8	4	1	0	0	13	14	1	0	6	0	0	0	0	7	6.2	0	0	11	1	0	0	0	12	12	
815 -	830	0	0	4	0	0	0	0	4	4	0	0	3	0	0	0	0	3	3	0	0	11	0	0	0	0	11	11	
830 -	845	1	0	5	2	0	0	0	8	7.2	0	0	5	0	0	0	0	5	5	0	0	5	1	0	0	0	6	6	Total
845 -	900	1	0	7	0	0	0	0	8	7.2	0	0	0	1	0	0	0	1	1	0	0	2	0	0	0	0	2	2	TOT/PCU
Hourly	Total	2	0	24	6	1	0	0	33	32	1	0	14	1	0	0	0	16	15	0	0	29	2	0	0	0	31	31	80 78

Formula PCU PCU 0.2 0.4 1 1 1.5 2 2.3 PCU 0.2 0.4 1 1 1.5 2 2.3 PCU 0.2 0.4 1 1 1.5 2 2.3

PM

Old Dover Road (NORTH)

		Left								Ahead								Right								Total			
TIME		P/CY	M/C'	CAR	LGV	OGV	OGV	BUS	TOT/	PCU	P/CY	M/C'	CAR	LGV	OGV	OGV	BUS	TOT/	PCU	P/CY	M/C'	CAR	LGV	OGV	OGV	BUS	TOT/	PCU	Total
1700 -	1715	0	0	20	0	0	0	0	20	20	1	0	97	4	0	0	0	101	101	0	0	7	2	0	0	0	9	9	
1715 -	1730	0	1	14	0	0	0	0	15	14	0	0	94	6	0	0	0	100	100	0	0	7	0	0	0	0	7	7	
1730 -	1745	0	0	16	0	0	0	1	17	18	0	0	109	7	0	0	1	117	118	0	0	9	1	0	0	0	10	10	Total
1745 -	1800	0	0	11	1	0	0	0	12	12	0	0	98	2	0	0	1	101	102	0	0	17	1	0	0	0	18	18	TOT/PCU
Hourly	Total	0	1	61	1	0	0	1	64	65	1	0	398	19	0	0	2	419	422	0	0	40	4	0	0	0	44	44	527 530

St Lawrence

		Left								Ahead								Right								Total			
TIME		P/CY	M/C'	CAR	LGV	OGV	OGV	BUS	TOT/	PCU	P/CY	M/C'	CAR	LGV	OGV	OGV	BUS	TOT/	PCU	P/CY	M/C'	CAR	LGV	OGV	OGV	BUS	TOT/	PCU	Total
1700 -	1715	0	0	31	0	0	0	0	31	31	0	0	3	0	0	0	0	3	3	0	0	5	0	0	0	0	5	5	
1715 -	1730	0	0	46	3	0	0	1	50	51	0	0	3	0	0	0	0	3	3	0	0	8	0	0	0	0	8	8	
1730 -	1745	1	0	35	1	0	0	0	36	36	0	0	2	0	0	0	0	2	2	1	0	4	0	0	0	0	4	4.2	Total
1745 -	1800	1	0	42	1	0	0	1	44	46	0	0	5	0	0	0	0	5	5	0	0	7	0	0	0	0	7	7	TOT/PCU
Hourly	Total	2	0	154	5	0	0	2	161	164	0	0	13	0	0	0	0	13	13	1	0	24	0	0	0	0	24	24	198 201

Old Dover F		Left								Ahead								Right										
TIME	P/CY	M/C'	CAR	LGV	OGV	OGV	BUS	TOT/	PCU	P/CY	M/C'	CAR	LGV	OGV	OGV	BUS	TOT/	PCU	P/CY	M/C'	CAR	LGV	OGV	OGV	BUS	TOT/	PCU	Total
1700 -	1715	0	0	12	0	0	0	12	12	0	0	36	1	0	0	2	39	42	0	0	23	2	0	0	0	25	25	
1715 -	1730	0	0	11	0	0	0	11	11	2	0	49	2	0	0	2	53	56	1	0	23	3	0	0	0	26	26	
1730 -	1745	0	0	10	13	0	0	23	23	0	0	48	3	0	0	4	55	60	1	0	28	0	0	0	0	28	28	Total
1745 -	1800	0	0	8	1	0	0	9	9	0	0	65	3	0	0	1	69	70	1	0	14	3	0	0	0	17	17	TOT/PCU
Hourly	Total	0	0	41	14	0	0	55	55	2	0	198	9	0	0	9	216	228	3	0	88	8	0	0	0	96	97	367 379

The Drive		Left								Ahead								Right										
TIME	P/CY	M/C'	CAR	LGV	OGV	OGV	BUS	TOT/	PCU	P/CY	M/C'	CAR	LGV	OGV	OGV	BUS	TOT/	PCU	P/CY	M/C'	CAR	LGV	OGV	OGV	BUS	TOT/	PCU	Total
1700 -	1715	0	0	17	0	0	0	17	17	0	0	15	0	0	0	0	15	15	0	0	21	1	0	0	0	12	22	
1715 -	1730	0	0	7	1	0	0	8	8	0	0	2	0	0	0	0	2	2	0	0	14	0	0	0	0	11	14	
1730 -	1745	1	0	6	1	0	0	7	7.2	0	0	9	0	0	0	0	9	9	0	0	5	0	0	0	0	6	5	Total
1745 -	1800	0	0	6	1	0	0	7	7	0	0	6	1	0	0	0	7	7	0	0	11	2	0	0	0	2	13	TOT/PCU
Hourly	Total	1	0	36	3	0	0	39	39	0	0	32	1	0	0	0	33	33	0	0	51	3	0	0	0	31	54	103 126
										PCU		0.4	1	1	1.5	2	2.3											

JUNCTIO Nackington Approach / Old Dover Road South

AM

Nackington Appro		Left to ODR (NORTH)								Right to ODR (SOUTH)									
TIME	P/CY	M/C'	CAR	LGV	OGV	OGV	BUS	TOT/	PCU	P/CY	M/C'	CAR	LGV	OGV	OGV	BUS	TOT/	PCU	Total
800 -	815	0	0	99	7	0	0	107	108	1	0	31	1	0	0	0	32	32	
815 -	830	0	0	90	4	2	0	98	102	0	0	16	1	0	0	1	18	19	
830 -	845	0	1	96	7	0	0	105	106	0	0	30	2	0	0	0	32	32	Total
845 -	900	0	0	92	9	2	1	109	118	0	0	16	0	0	0	1	17	18	TOT/PCU
Hourly	Total	0	1	377	27	4	1	419	433	1	0	93	4	0	0	2	99	102	518 535

Old Dover Road (N)		Ahead to ODR (Sth)								Right To Nackington									
TIME	P/CY	M/C'	CAR	LGV	OGV	OGV	BUS	TOT/	PCU	P/CY	M/C'	CAR	LGV	OGV	OGV	BUS	TOT/	PCU	Total
800 -	815	1	0	40	1	0	0	42	44	1	1	59	9	2	1	1	73	76	
815 -	830	5	0	35	1	0	0	36	37	0	3	79	8	1	0	2	93	94	
830 -	845	0	0	23	1	0	0	25	26	0	0	59	5	1	0	4	69	75	Total
845 -	900	2	0	11	1	0	0	12	12	1	0	48	6	1	0	2	57	60	TOT/PCU
Hourly	Total	8	0	109	4	0	0	115	119	2	4	245	28	5	1	9	292	305	407 424

Old Dover Road Sc

Left to Nackington

Ahead to Old Dover Road (Nrth)

TIME	P/CY	M/C'	CAR	LGV	OGV	OGV	BUS	TOT/PCU	P/CY	M/C'	CAR	LGV	OGV	OGV	BUS	TOT/PCU	Total
800 - 815	1	0	9	0	0	0	1	11 12	0	2	43	5	0	0	1	51 51	
815 - 830	0	0	15	0	0	0	0	15 15	0	0	27	3	0	1	6	37 46	
830 - 845	0	0	19	1	0	0	2	22 25	0	0	32	3	0	0	6	41 49	Total
845 - 900	0	0	18	2	0	0	0	20 20	1	0	47	1	0	0	7	55 64	TOT/PCU
Hourly Total	1	0	61	3	0	0	3	68 71	1	2	149	12	0	1	20	184 210	252 281

PM

Nackir Approach

Left to ODR (North)

Right to ODR (South)

TIME	P/CY	M/C'	CAR	LGV	OGV	OGV	BUS	TOT/PCU	P/CY	M/C'	CAR	LGV	OGV	OGV	BUS	TOT/PCU	Total
1700 - 1715	0	0	40	3	0	0	0	43 43	0	0	32	1	0	0	0	33 33	
1715 - 1730	1	0	46	5	0	0	1	52 54	0	0	20	0	0	0	1	21 22	
1730 - 1745	2	0	59	3	0	0	0	62 62	0	0	23	1	0	0	1	25 26	Total
1745 - 1800	1	0	55	0	0	0	0	55 55	0	0	19	0	0	0	1	20 21	TOT/PCU
Hourly Total	4	0	200	11	0	0	1	212 214	0	0	94	2	0	0	3	99 103	311 317

Old Dover Road N

Ahead to ODR (South)

Right to Nackington

TIME	P/CY	M/C'	CAR	LGV	OGV	OGV	BUS	TOT/PCU	P/CY	M/C'	CAR	LGV	OGV	OGV	BUS	TOT/PCU	Total
1700 - 1715	0	0	63	4	0	0	0	67 67	0	0	90	1	0	0	0	91 91	
1715 - 1730	0	0	55	3	0	0	0	58 58	0	0	94	5	0	0	0	99 99	
1730 - 1745	0	0	54	3	0	0	1	58 59	1	0	106	3	0	0	0	109 109	Total
1745 - 1800	0	0	49	3	0	0	0	52 52	1	0	100	3	0	0	1	104 106	TOT/PCU
Hourly Total	0	0	221	13	0	0	1	235 236	2	0	390	12	0	0	1	403 405	638 641

Old Dover Road Sc

Left to Nackington

Ahead to ODR (North)

TIME	P/CY	M/C'	CAR	LGV	OGV	OGV	BUS	TOT/PCU	P/CY	M/C'	CAR	LGV	OGV	OGV	BUS	TOT/PCU	Total
1700 - 1715	0	1	22	0	0	0	1	24 25	2	0	22	0	0	0	2	24 27	
1715 - 1730	1	0	26	1	0	0	1	28 30	0	0	33	0	0	0	2	35 38	
1730 - 1745	0	0	18	0	1	0	1	20 22	0	0	27	2	1	0	3	33 37	Total
1745 - 1800	0	0	29	2	0	0	0	31 31	0	0	32	3	1	0	1	37 39	TOT/PCU
Hourly Total	1	1	95	3	1	0	3	103 107	2	0	114	5	2	0	8	129 141	232 248

Total

APPENDIX B

Signal Configuration Plans

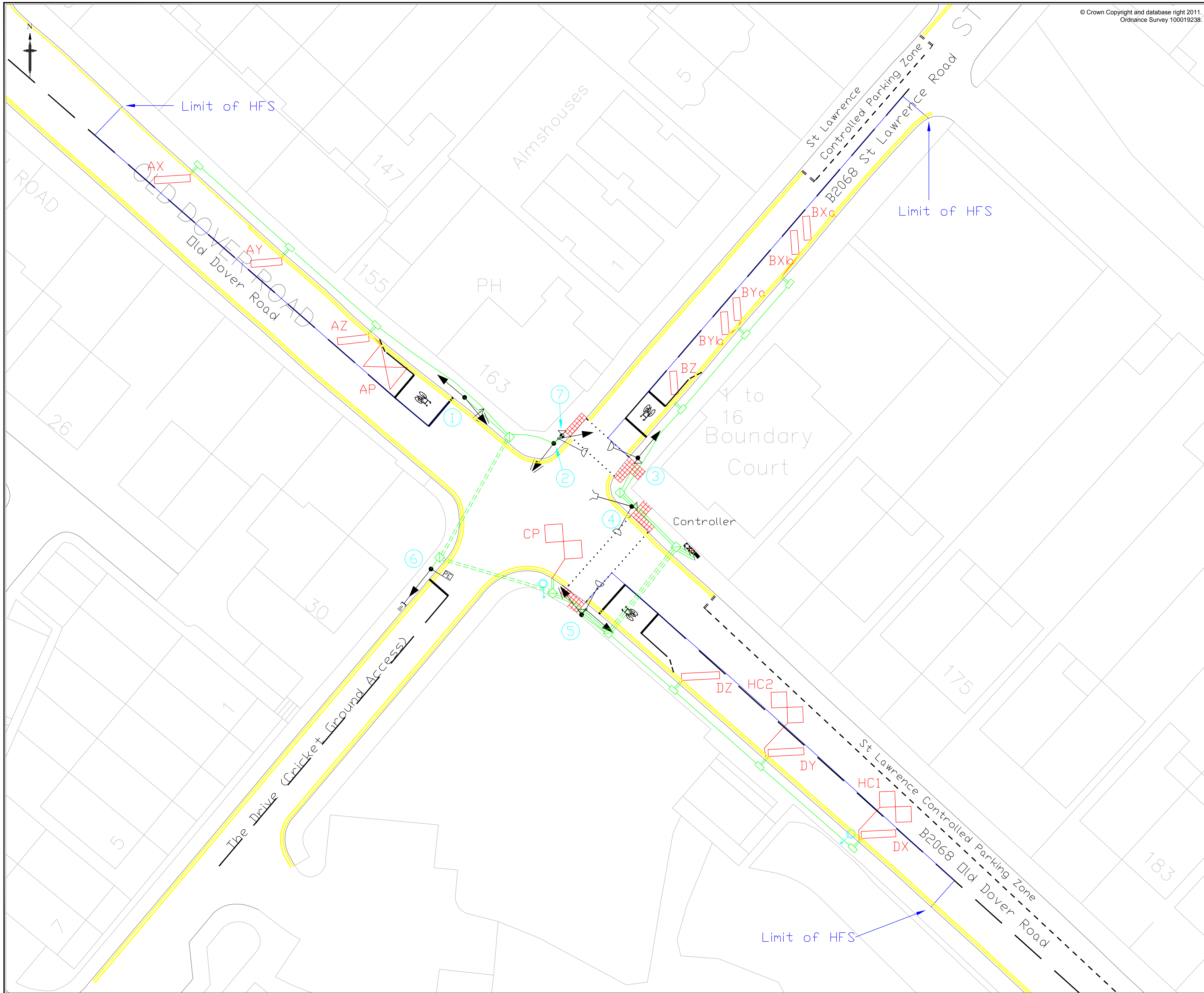

Key

- [Symbol] Junction box 550 mm depth (no under kerb ducts)
- [Symbol] Junction box 550 mm depth (with under kerb ducts)
- [Symbol] Junction pit 900 mm depth (no under kerb ducts)
- [Symbol] Junction pit 900 mm depth (with under kerb ducts)
- [Symbol] Junction pit 500 mm depth (no under kerb ducts)
- [Symbol] Junction pit 500 mm depth (with under kerb ducts)
- [Symbol] Duct FW/1 100 mm dia
- [Symbol] Duct FW/2 100 mm dia
- [Symbol] Duct FW/3 100 mm dia
- [Symbol] Duct CW/2 100 mm dia
- [Symbol] Duct CW/3 100 mm dia
- [Symbol] Duct CW/4 100 mm dia
- [Symbol] Signal controller cabinet
- [Symbol] Electricity supply pillar
- [Symbol] BT termination pillar
- AX [Symbol] Vehicle detector loop and identity
- [Symbol] Traffic signal and pole
- [Symbol] Traffic signal with secondary hoods
- [Symbol] Pedestrian signal
- [Symbol] Short pole
- [Symbol] Pedestrian push button unit
- [Symbol] Microwave vehicle detector
- [Symbol] Pedestrian / cycle on crossing detector
- [Symbol] Visual pedestrian or vehicle presence detector
- [Symbol] Photo electric cell
- [Symbol] Bus priority receiver
- [Symbol] Layout of blister tactile surface modules (red)
- [Symbol] Roadstuds
- [Symbol] Existing lighting column
- [Symbol] Guardrail type PG/1 - HV (staggered infill bars)
- [Symbol] HFS (HFS beyond stopline must be coloured Grey)

- Notes**
- This drawing is based on Ordnance Survey digital data supplemented by additional base detail measured on site. Original drawing 2862/S/IF.
 - High Friction Surface (HFS) shall extend 50m in advance of the stopline on each approach. The HFS shall extend to the first row of pedestrian studs beyond the stopline. On High Speed Roads, the HFS shall extend to the second row of pedestrian studs beyond the stopline. All HFS beyond the stopline shall be coloured grey.
 - This drawing shall be read in conjunction with KCC Standard Details:-
KCC/400/002 - Pedestrian guardrail
KCC/500/020 to 025 - Ducting and Junction Pits
KCC/1100/007 - Tactile paving at controlled pedestrian crossings points
KCC/1200/007 and /008 - Installation of signal equipment
KCC/1200/009 - Traffic Signal Pole Retention Socket.
 - This drawing shall be read in conjunction with the Contract Specification Appendices:-
Appendix 5/2 - Service Duct requirements.
Appendix 12/3 - Traffic Signs: Studs.
Appendix 12/5 - Traffic Signs: Traffic Signals.
Appendix 14/5 - Electrical Equipment.
 - Bus priority cable shall terminate in pole 6 and be tagged at the pole and in the controller 'Bus Priority'.
 - Ducting shall be adjusted locally to avoid existing Statutory Undertakers Plant.
 - The details of any existing services shown on this drawing are based upon information supplied by the statutory bodies and other authorities concerned. The accuracy of this information cannot be guaranteed and the presence of other apparatus, in particular service connections to individual properties, should be expected.

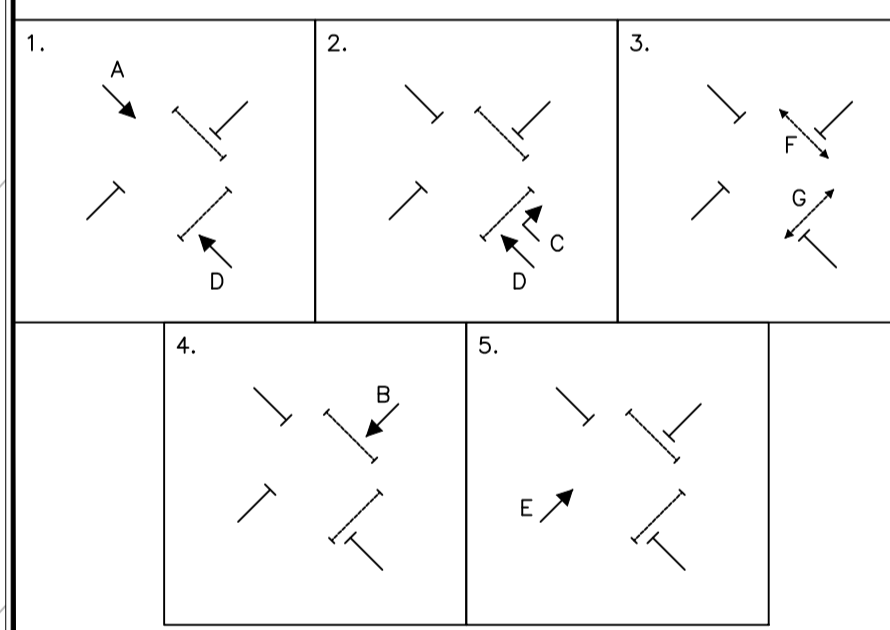

1	19/10/14	Revised OS base information Adjusted location of Pole 6 for new layout	IB		
0	08/04/14	As built drawing transferred to current theme TrafficCam fitted to pole 6 replacing EP loop	IB		
Rev	Revision Date	Purpose of revision	Drawn	Checked	Approved



Kent County Council
Aylesford Highway Depot
St. Michael's Close
Aylesford ME20 7BU
Tel: 03000 41 81 81

Project: **Intelligent Transport Systems**

Drawing title: **B2068 Old Dover Road/ St Lawrence Road, Canterbury Site Ref: 06/0061**

Drawing status: **As Built**

Scale: **1:200 at A1 Do not scale**

Drawing number: **ITS/2014/S/06-0061** Rev: **1**

This drawing is not to be used in whole or part other than for the intended purpose and project as defined on this drawing. Refer to the contract for full terms and conditions.



KENT COUNTY COUNCIL

TRAFFIC SIGNAL DATA SHEET

CONTROLLER

MANUFACTURER **Siemens**

TYPE **ST800**

REF NO **06/ 0060** SITE **B2068 Old Dover Road/ Nackington Road** TOWN **Canterbury**

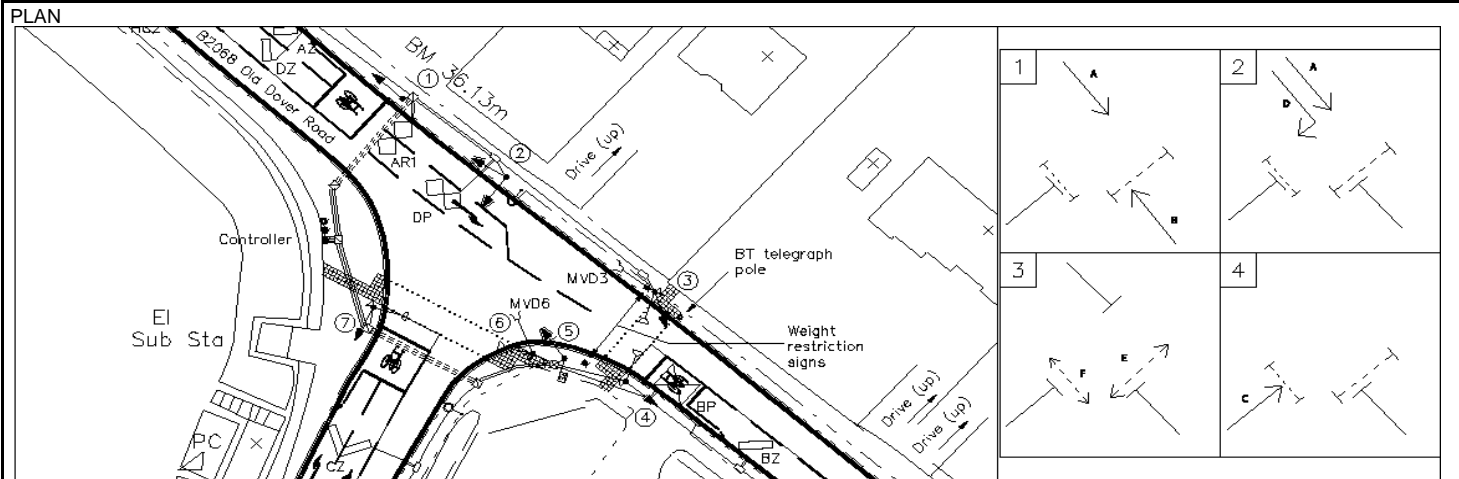

APPROACH	PHASE	MIN	PED B/OUT	MAX A	MAX B	MAX C	MAX D	EXT	DEMANDED BY DET NO	DEMANDED BY DET NAME	EXTENDED BY DET NO	EXTENDED BY DET NAME
Old Dover Road (NW) Ahead	A	7	-	20	15	15	15	1.6	2,3	AY,AZ	1,2,3	AX,AY,AZ
Old Dover Road (SE)	B	7	-	25	15	15	15	1.6	3,4,5,6	BX,BY,BZ,BP	3,4,5	BX,BY,BZ
Nackington Road	C	7	-	35	15	20	15	1.6	7,8,9	CX,CY,CZ	7,8,9	CX,CY,CZ
Old Dover Road (NW) RT IGA	D	4	-	20	10	35	10	1.6	13	DP	10,11,12	DX,DY,DZ
Peds across Old Dover Road (SE)	E	6	4	6	6	6	6	-	51,52	PB3E,PB4E	-	-
Peds across Nackington Road	F	7	8	7	7	7	7	-	53,54	PB6F,PB7F	-	-
Dummy All Red	G	1	-	1	1	1	1	-	-	-	50	MVD6
	H											
	I											
	J											
	K											
	L											
	M											
	N											
	O											
	P											

STAGE INTERGREEN TIMES										ADDITIONAL PHASE DELAYS				SPECIAL FEATURES # - Hurry Call is demanded by call cancel units HC1 and HC2 output true together Timetable Mo - Fr 0730 MAX 0930 MBX 1500 MCX 1830 MDX Sa 0730 MBX 1900 MDX Su 0830 MBX 1830 MDX		
TO FROM	1	2	3	4	5	6	7	8	9	10	NO	DELAY PHASE	FROM STAGE		TO STAGE	BY (SECS)
1		5	9-17	7							1					
2	6		9-17	7							2					
3	14	14		14							3					
4	5	5	9								4					
5											5					
6											6					
7											7					
8											8					
9											9					
10											10					

DETECTOR MONITOR (AS SEEN ON ENGINEERS TERMINAL)									HURRY CALLS				BUS PRIORITY CALLS								
IOP	7	6	5	4	3	2	1	0	HC	STAGE	DEMD	CALL DELAY	HOLD	PVENT	UNIT	PHASE	EXT	MAX	COMP	INHIBIT	DFM(s)
0	CX	BP	BZ	BY	BX	AZ	AY	AX	0	2	#	0	30	80	0	A	10	30	-	120	600
1	HC1	AR1	DP	DZ	DY	DX	CZ	CY	1						1	B	10	30	-	120	600
6	BPA	PB7F	PB6F	PB4E	PB3E	MVD6	MVD3	HC2							2	C	10	30	-	120	600
7	-	-	-	-	-	BPD	BPC	BPB							3	D	10	30	-	120	600

REVERSION STAGE	DFM PERIOD (HRS)	STARTING INTERGR'N (S)	F.T. TO CURRENT <input checked="" type="checkbox"/>	F.T. MODE STAGE GREEN TIME	COMMISSIONED	CONFIG NUMBER	DATA PREPARED	FILE REFERENCE	MANUAL CONTROL	PB STAGE	OTU X No	LINK LIST	BT CIRCUIT	AutoCAD file
1	1/18	13			23 May 2003	E62260 5.0.21	17 Jan 11	06/0060	PC	1 2 3 4 5 6 7 8	X31210	-	01227 478511	As Built Dwg 06-0060

Works Order : 5790/484/3
EM Number : 66221
Engineer : marco Gmys
Intersection : B2068 Old Dover / St Lawrence Rd, Canterbury. 06/061

Administration

General Specifications

Customer Name	<input type="text" value="Kent County Council"/>	Customer Order No.	<input type="text"/>
Intersection/ General Description	<input type="text" value="B2068 Old Dover / St Lawrence Rd,
Canterbury.
06/061"/>	Controller/ Serial Number	<input type="text"/>
Controller	<input checked="" type="radio"/> New <input type="radio"/> Modification	S.T.S. /EM Number	<input type="text" value="66221"/> Issue <input type="text" value="10"/>
Area Specifications/ Customer Drawings	<input type="text" value="Drawing No. 2862/S/1E"/>	Equipment Installation by	<input type="text" value="Signal Company"/>
Specification Section	<input type="text" value="KCC General Specification Issue 3.0"/>	Slot Cutting by	<input type="text" value="Signal Company"/>
Contract/Tender Ref:	<input type="text"/>	Civil Works by	<input type="text" value="Civil Contractor"/>
Quotation No.	<input type="text"/>	Customer's Engineer	<input type="text" value="Paul Clark"/>
Works Order No.	<input type="text" value="5790/484/3"/>	Telephone Number	<input type="text" value="01622 666063"/>

Signal Company Use Only

Signal Engineer	<input type="text" value="marco Gmys"/>	(IF PROM Label as >) PROM Number	<input type="text" value="16274"/>	PROM Variant	<input type="text" value="174"/>
		Configuration Check Value	<input type="text" value="2B BD 74 C6"/>		

Controller Options

Hardware	<input type="text" value="T800"/>	Firmware Type and Issue	<input type="text" value="PB800 ISS 19"/>	Other Options	<input type="text" value="KTD LO"/>
----------	-----------------------------------	-------------------------	---	---------------	-------------------------------------

ST950/ST900/ST750 Series Cabinet Options

Cabinet/Rack	Kit Type Options	<input type="radio"/>	<input type="radio"/>	<input type="radio"/>	<input type="radio"/>
Cabinet/Rack Variant	Cuckoo Options	<input type="checkbox"/>			

Mains Supply	<input type="text" value="230"/> Volts	<input type="text" value="50"/> Hz					
Peak Lamp Current	<input type="text" value="9"/> Amps	Dimming Voltage	<input type="text" value="160"/>	Answer Issue	<input type="text" value="0"/>	Date Created	<input type="text" value="11/02/03"/>
Average Lamp Power	<input type="text" value="1600"/> Watts	Low Inrush Transformer	<input type="checkbox"/>	Edit Issue	<input type="text" value="46"/>		
Total Average Power	<input type="text" value="1600"/> Watts						

Power feed fuse rating: requires 30 Amp minimum for controller, 15 Amp minimum for pelican/lightly loaded controller

Phases, Stages and Streams

Phases, Stages and Streams

Add/Delete/Insert Streams:

Streams	
<input checked="" type="radio"/>	Current Number of Streams <input type="text" value="1"/>

Phases	
<input type="radio"/>	Current Total Number of Phases <input type="text" value="11"/>
<input checked="" type="radio"/>	Number of Real Phases <input type="text" value="7"/>
<input type="radio"/>	Number of Dummy Phases <input type="text" value="4"/>

Stages	
<input type="radio"/>	Current Number of stages (inc. ALL-RED stages) <input type="text" value="6"/>

Switched Signs	
<input type="radio"/>	Number of Switched Signs <input type="text" value="0"/>

Action	
<input type="button" value="Add At"/>	<input type="button" value="Delete At"/>

Facilities/Modes Enabled and Mode Priority Levels

Facilities

UTC <input checked="" type="checkbox"/> Serial/Internal UTMC OTU <input type="checkbox"/> Free-standing OTU <input type="checkbox"/> Integral TC12 OTU <input checked="" type="checkbox"/> Serial MOVA	<input checked="" type="checkbox"/> Master Time Clock <input type="checkbox"/> Holiday Clock <input checked="" type="checkbox"/> FT To Current MAX <input type="checkbox"/> Linked Fixed Time	<input type="checkbox"/> Lamp Monitoring <input type="checkbox"/> RED Lamp Monitoring <input type="checkbox"/> Pelican/Puffin/Toucan <input type="checkbox"/> Standalone Manual	<input checked="" type="checkbox"/> Extend All Red <input type="checkbox"/> Speed Measurement <input type="checkbox"/> Ripple Change <input type="checkbox"/> London IMU	<input type="checkbox"/> Non-UK <input type="checkbox"/> Fail to Part Time <input type="checkbox"/> Fail To Hardware Flashing <input type="checkbox"/> Download To Level 3
--	--	--	---	---

Starting Intergreen

Mode Priority

	1	2	3	4	5	6	7	8	9	10	11	12	13
<input type="checkbox"/> Part Time	<input type="radio"/>	<input type="radio"/>	<input type="radio"/>	<input type="radio"/>	<input type="radio"/>	<input type="radio"/>	<input type="radio"/>	<input type="radio"/>	<input type="radio"/>	<input type="radio"/>	<input type="radio"/>	<input type="radio"/>	<input type="radio"/>
<input type="checkbox"/> Emergency Vehicles	<input type="radio"/>	<input type="radio"/>	<input type="radio"/>	<input type="radio"/>	<input type="radio"/>	<input type="radio"/>	<input type="radio"/>	<input type="radio"/>	<input type="radio"/>	<input type="radio"/>	<input type="radio"/>	<input type="radio"/>	<input type="radio"/>
<input checked="" type="checkbox"/> Hurry Call	<input type="radio"/>	<input checked="" type="radio"/>	<input type="radio"/>	<input type="radio"/>	<input type="radio"/>	<input type="radio"/>	<input type="radio"/>	<input type="radio"/>	<input type="radio"/>	<input type="radio"/>	<input type="radio"/>	<input type="radio"/>	<input type="radio"/>
<input type="checkbox"/>	<input type="radio"/>	<input type="radio"/>	<input type="radio"/>	<input type="radio"/>	<input type="radio"/>	<input type="radio"/>	<input type="radio"/>	<input type="radio"/>	<input type="radio"/>	<input type="radio"/>	<input type="radio"/>	<input type="radio"/>	<input type="radio"/>
<input checked="" type="checkbox"/> Priority Vehicle	<input type="radio"/>	<input type="radio"/>	<input type="radio"/>	<input type="radio"/>	<input type="radio"/>	<input checked="" type="radio"/>	<input type="radio"/>	<input type="radio"/>	<input type="radio"/>	<input type="radio"/>	<input type="radio"/>	<input type="radio"/>	<input type="radio"/>
<input checked="" type="checkbox"/> Manual Control	<input checked="" type="radio"/>	<input type="radio"/>	<input type="radio"/>	<input type="radio"/>	<input type="radio"/>	<input type="radio"/>	<input type="radio"/>	<input type="radio"/>	<input type="radio"/>	<input type="radio"/>	<input type="radio"/>	<input type="radio"/>	<input type="radio"/>
<input type="checkbox"/> Manual Step On	<input type="radio"/>	<input type="radio"/>	<input type="radio"/>	<input type="radio"/>	<input type="radio"/>	<input type="radio"/>	<input type="radio"/>	<input type="radio"/>	<input type="radio"/>	<input type="radio"/>	<input type="radio"/>	<input type="radio"/>	<input type="radio"/>
<input checked="" type="checkbox"/> Selected FT or VA or CLF	<input type="radio"/>	<input type="radio"/>	<input checked="" type="radio"/>	<input type="radio"/>	<input type="radio"/>	<input type="radio"/>	<input type="radio"/>	<input type="radio"/>	<input type="radio"/>	<input type="radio"/>	<input type="radio"/>	<input type="radio"/>	<input type="radio"/>
<input checked="" type="checkbox"/> UTC	<input type="radio"/>	<input type="radio"/>	<input type="radio"/>	<input checked="" type="radio"/>	<input type="radio"/>	<input type="radio"/>	<input type="radio"/>	<input type="radio"/>	<input type="radio"/>	<input type="radio"/>	<input type="radio"/>	<input type="radio"/>	<input type="radio"/>
<input type="checkbox"/>	<input type="radio"/>	<input type="radio"/>	<input type="radio"/>	<input type="radio"/>	<input type="radio"/>	<input type="radio"/>	<input type="radio"/>	<input type="radio"/>	<input type="radio"/>	<input type="radio"/>	<input type="radio"/>	<input type="radio"/>	<input type="radio"/>
<input checked="" type="checkbox"/> CLF (Non-Base Time)	<input type="radio"/>	<input type="radio"/>	<input type="radio"/>	<input type="radio"/>	<input checked="" type="radio"/>	<input type="radio"/>	<input type="radio"/>	<input type="radio"/>	<input type="radio"/>	<input type="radio"/>	<input type="radio"/>	<input type="radio"/>	<input type="radio"/>
<input type="checkbox"/> CLF (Base Time)	<input type="radio"/>	<input type="radio"/>	<input type="radio"/>	<input type="radio"/>	<input type="radio"/>	<input type="radio"/>	<input type="radio"/>	<input type="radio"/>	<input type="radio"/>	<input type="radio"/>	<input type="radio"/>	<input type="radio"/>	<input type="radio"/>
<input checked="" type="checkbox"/> Vehicle Actuated	<input type="radio"/>	<input type="radio"/>	<input type="radio"/>	<input type="radio"/>	<input type="radio"/>	<input type="radio"/>	<input checked="" type="radio"/>	<input type="radio"/>	<input type="radio"/>	<input type="radio"/>	<input type="radio"/>	<input type="radio"/>	<input type="radio"/>
<input checked="" type="checkbox"/> Fixed Time	<input type="radio"/>	<input type="radio"/>	<input type="radio"/>	<input type="radio"/>	<input type="radio"/>	<input type="radio"/>	<input type="radio"/>	<input type="radio"/>	<input type="radio"/>	<input type="radio"/>	<input checked="" type="radio"/>	<input type="radio"/>	<input type="radio"/>

Configuration Complexity

Low
 Medium
 High
 Maximum

standard.8DF

Default PROM data file

Correspondence Monitoring to inc.

Reds
 Ambers
 Switched Signs
 Ignore Reds and Ambers during

Flash Rate (ms)

Off
 On

Phases in Stages

Phases

	A	B	C	D	E	F	G	H	I	J	K
0								■			
1	■			■							
2			■	■							
3						□	□		■	□	□
4		■									
5					■						

Works Order : 5790/484/3
 EM Number : 66221
 Engineer : marco Gmys
 Intersection : B2068 Old Dover / St Lawrence Rd, Canterbury. 06/061

Stages in Streams

Stages in Streams

0 1 2 3 4 5 6 7

Phase or Stage to revert to in absence of demands/extensions

Startup Stage

Switch Off Stage

Standalone Pedestrian

Note: For a Stand-Alone Stream, the reversion must be to All Red stage or Traffic stage/phase to meet the relevant standard or specification.

Stages

In Stream

	0	1	2	3	4	5
0						

Works Order : 5790/484/3
 EM Number : 66221
 Engineer : marco Gmys
 Intersection : B2068 Old Dover / St Lawrence Rd, Canterbury. 06/061

Phase Type and Conditions

Phase Type and Conditions

Phases A to P

Phase	Title	Type	App. Type	Term. Type	Assoc. Phase
A	Old Dover Rd NW	0 - UK Traffic	0	0 - I	
B	St Lawrence Rd	0 - UK Traffic	0	0 - I	
C	Old Dover Rd SE RT	2 - UK GreenArrow	0	2 - I	D
D	Old Dover Rd SE	0 - UK Traffic	0	0 - I	
E	The Drive	0 - UK Traffic	0	0 - I	
F	Peds across St Lawrence Rd	1 - UK Far Side Pedestrian	2	0 - I	
G	Peds across Old Dover Rd SE	1 - UK Far Side Pedestrian	2	0 - I	
H	Dummy All Red	2 - UK GreenArrow	0	0 - I	
I	Fixed Phase to appear in Stage 3	1 - UK Far Side Pedestrian	0	0 - I	
J	Phase F dummy	1 - UK Far Side Pedestrian	1	0 - I	
K	Phase G dummy	1 - UK Far Side Pedestrian	1	0 - I	

1) App Types: 0 = Always Appears, 1 = Appears if dem'd prior to interstage, 2 = If dem'd, 3 = If dem'd before end of window time
 2) Term Types: 0 = Term's at end of stage, 1 = Term's when Assoc phase gains R.O.W, 2 = Term's when Assoc phase loses R.O.W.
 3) The H/W Fail Flash fields are for information only on all but ST900ELV Controllers. For other controllers, physical switches or links (etc.) select which aspects flash and these need to be set up manually.

Opposing and Conflicting Phases

Select Stream(s) To Configure

All
 0

Initialise

To Phase

		A	B	C	D	E	F	G	H	I	J	K
From Phase	A	■	Co	Co	o	Co	Co	Co	o	o	o	o
	B	Co	■	Co	Co	Co	Co	Co	o	o	o	o
	C	Co	Co	■	o	Co	Co	Co	o	o	o	o
	D	o	Co	o	■	Co	Co	Co	o	o	o	o
	E	Co	Co	Co	Co	■	Co	Co	o	o	o	o
	F	Co	Co	Co	Co	Co	■	o	o	o	o	o
	G	Co	Co	Co	Co	Co	o	■	o	o	o	o
	H	o	o	o	o	o	o	o	■	o	o	o
	I	o	o	o	o	o	o	o	o	■	o	o
	J	o	o	o	o	o	o	o	o	o	■	o
	K	o	o	o	o	o	o	o	o	o	o	■

Phase Minimums, Maximums, Extensions, Ped Leaving Periods

Phase Minimums, Maximums, Extensions, Ped Leaving Periods

Phases A to P

Phase	Min Green	Min Ped Clr	Extensions	Maximums								Pre-timed	
				A	B	C	D	E	F	G	H		
A	7	0	1.6	30	20	40	20	0	0	0	0	0	<input type="checkbox"/>
B	7	0	1.0	20	15	15	12	0	0	0	0	0	<input type="checkbox"/>
C	4	0	0.0	15	10	10	10	0	0	0	0	0	<input type="checkbox"/>
D	7	0	1.6	60	40	45	20	0	0	0	0	0	<input type="checkbox"/>
E	7	0	0.6	12	12	12	12	0	0	0	0	0	<input type="checkbox"/>
F	6	4	0.0	6	6	6	6	0	0	0	0	0	<input type="checkbox"/>
G	6	7	0.0	6	6	6	6	0	0	0	0	0	<input type="checkbox"/>
H	1	0	0.0	1	1	1	1	0	0	0	0	0	<input type="checkbox"/>
I	3	0	0.0	0	0	0	0	0	0	0	0	0	<input type="checkbox"/>
J	6	0	0.0	0	0	0	0	0	0	0	0	0	<input type="checkbox"/>
K	6	0	0.0	0	0	0	0	0	0	0	0	0	<input type="checkbox"/>
													<input type="checkbox"/>
													<input type="checkbox"/>
													<input type="checkbox"/>
													<input type="checkbox"/>
													<input type="checkbox"/>

Note: For Standalone Streams see Help for use of Max Sets.

Phase Intergreen Times

Select Stream(s) To Configure

All
 0

Note: On a Stand Alone Pelican/Toucan/Puffin Stream the Intergreens between Pedestrian and Traffic Phases are controlled by the timings (PBT, PIT, CMX, CDY, CRD and PAR), therefore 0 should be entered for the appropriate intergreen times in grid below.

To Phase

From Phase

	A	B	C	D	E	F	G	H	I	J	K
A		6	5		6	8	8	3	8	8	8
B	5		5	5	6	5	7	3	7	5	7
C	6	5			6	8	5	3	8	8	5
D		5			6	8	5	3	8	8	5
E	5	5	5	5		7	8	3	8	7	8
F	8	8	8	8	8			4			
G	12	12	12	12	12			7			
H	0	0	3	3	0	0	0				
I											
J											
K											

Intergreen Handset Limits

HIGH 199

Copy Intergreen Values

To Phase

From Phase

	A	B	C	D	E	F	G	H	I	J	K
A		5	5		5	6	6	3	6	6	6
B	5		5	5	5	5	5	3	5	5	5
C	5	5			5	6	5	3	6	6	5
D		5			5	6	5	3	6	6	5
E	5	5	5	5		5	6	3	6	5	6
F	6	6	6	6	6			4			
G	9	9	9	9	9			5			
H			3	3							
I											
J											
K											

Phase Timing Handset Ranges

Initialise Min Green Limits

Phase	Min. Green		Phase	Min. Green	
	Min.	Max.		Min.	Max.
A	<input type="text" value="3"/>	<input type="text" value="255"/>	Q		
B	<input type="text" value="3"/>	<input type="text" value="255"/>	R		
C	<input type="text" value="3"/>	<input type="text" value="255"/>	S		
D	<input type="text" value="3"/>	<input type="text" value="255"/>	T		
E	<input type="text" value="3"/>	<input type="text" value="255"/>	U		
F	<input type="text" value="3"/>	<input type="text" value="255"/>	V		
G	<input type="text" value="3"/>	<input type="text" value="255"/>	W		
H	<input type="text" value="1"/>	<input type="text" value="255"/>	X		
I	<input type="text" value="3"/>	<input type="text" value="255"/>	Y		
J	<input type="text" value="3"/>	<input type="text" value="255"/>	Z		
K	<input type="text" value="3"/>	<input type="text" value="255"/>	A2		
L			B2		
M			C2		
N			D2		
O			E2		
P			F2		

Max. Green Min. <input type="text" value="0"/> Max. <input type="text" value="255"/>	
Vehicle Extension Min. <input type="text" value="0.0"/> Max. <input type="text" value="10.0"/>	
Phase Delay Min. <input type="text" value="0"/> Max. <input type="text" value="10"/>	
Starting I/G Min. <input type="text" value="4"/> Max. <input type="text" value="12"/>	
Min Pedestrian Clearance (PBT) Min. <input type="text" value="0"/> Max. <input type="text" value="12"/>	
Traffic Phase Leaving Min. <input type="text" value="3.0"/> Max. <input type="text" value="3.0"/>	
Traffic Phase Red/Amber Min. <input type="text" value="2"/> Max. <input type="text" value="2"/>	

VA Demand and Extend Definitions

VA Demand and Extend Definitions

Demands

For Unlatched demands precede the name with a #.
Conditioning MUST be used to specify unlatched demands.

Phase	AX	AY	AZ	BPA
A				
B				
C	BPC			
D	DX	DY	DZ	BPD
E				
F				
G				
H				
I				
J	PB2F	PB3F		
K	PB4G	PB5G		

Phases A to P

Extensions

AX	AY	AZ	
BX	BY	BZ	
CP			
DX	DY	DZ	
MVD6			

Phase Internal/Revertive Demands

Phase Internal/Revertive Demands

Start-up Vehicle Responsive Demands

A	<input checked="" type="checkbox"/>	B	<input checked="" type="checkbox"/>	C	<input checked="" type="checkbox"/>	D	<input checked="" type="checkbox"/>	E	<input checked="" type="checkbox"/>	F	<input type="checkbox"/>	G	<input type="checkbox"/>	H	<input type="checkbox"/>	I	<input type="checkbox"/>	J	<input checked="" type="checkbox"/>	K	<input checked="" type="checkbox"/>		<input type="checkbox"/>		<input type="checkbox"/>		<input type="checkbox"/>		<input type="checkbox"/>		<input type="checkbox"/>
	<input type="checkbox"/>		<input type="checkbox"/>		<input type="checkbox"/>		<input type="checkbox"/>		<input type="checkbox"/>		<input type="checkbox"/>		<input type="checkbox"/>		<input type="checkbox"/>		<input type="checkbox"/>		<input type="checkbox"/>		<input type="checkbox"/>		<input type="checkbox"/>		<input type="checkbox"/>		<input type="checkbox"/>		<input type="checkbox"/>		

Demands Inserted When Leaving Manual and Fixed Time Modes

A	<input checked="" type="checkbox"/>	B	<input checked="" type="checkbox"/>	C	<input checked="" type="checkbox"/>	D	<input checked="" type="checkbox"/>	E	<input checked="" type="checkbox"/>	F	<input type="checkbox"/>	G	<input type="checkbox"/>	H	<input type="checkbox"/>	I	<input type="checkbox"/>	J	<input checked="" type="checkbox"/>	K	<input checked="" type="checkbox"/>		<input type="checkbox"/>		<input type="checkbox"/>		<input type="checkbox"/>		<input type="checkbox"/>		<input type="checkbox"/>
	<input type="checkbox"/>		<input type="checkbox"/>		<input type="checkbox"/>		<input type="checkbox"/>		<input type="checkbox"/>		<input type="checkbox"/>		<input type="checkbox"/>		<input type="checkbox"/>		<input type="checkbox"/>		<input type="checkbox"/>		<input type="checkbox"/>		<input type="checkbox"/>		<input type="checkbox"/>		<input type="checkbox"/>		<input type="checkbox"/>		<input type="checkbox"/>

Unlatched Demands that Start Max Timers

A	<input checked="" type="checkbox"/>	B	<input checked="" type="checkbox"/>	C	<input checked="" type="checkbox"/>	D	<input checked="" type="checkbox"/>	E	<input checked="" type="checkbox"/>	F	<input checked="" type="checkbox"/>	G	<input checked="" type="checkbox"/>	H	<input type="checkbox"/>	I	<input type="checkbox"/>	J	<input checked="" type="checkbox"/>	K	<input checked="" type="checkbox"/>		<input type="checkbox"/>		<input type="checkbox"/>		<input type="checkbox"/>		<input type="checkbox"/>		<input type="checkbox"/>
	<input type="checkbox"/>		<input type="checkbox"/>		<input type="checkbox"/>		<input type="checkbox"/>		<input type="checkbox"/>		<input type="checkbox"/>		<input type="checkbox"/>		<input type="checkbox"/>		<input type="checkbox"/>		<input type="checkbox"/>		<input type="checkbox"/>		<input type="checkbox"/>		<input type="checkbox"/>		<input type="checkbox"/>		<input type="checkbox"/>		<input type="checkbox"/>

Revertive Phase Demands

A	B	C	D	E	F	G	H	I	J	K	L	M	N	O	P
<input type="checkbox"/>	<input type="checkbox" value="B"/>	<input type="checkbox" value="D"/>	<input type="checkbox" value="D"/>	<input type="checkbox"/>	<input type="checkbox"/>	<input type="checkbox"/>	<input type="checkbox"/>	<input type="checkbox"/>	<input type="checkbox"/>	<input type="checkbox"/>					
Q	R	S	T	U	V	W	X	Y	Z	A2	B2	C2	D2	E2	F2

Stages - Prohibited, Alternative, Ignored Moves

Stages - Prohibited, Alternative, Ignored Moves

- Sets
- 1
 - 2
 - 3
 - 4

Modes	Restrictions Apply To:	No Restrictions
	<input checked="" type="radio"/>	<input type="radio"/>
	<input checked="" type="radio"/>	<input type="radio"/>
	<input checked="" type="radio"/>	<input type="radio"/>
	<input checked="" type="radio"/>	<input type="radio"/>
	<input checked="" type="radio"/>	<input type="radio"/>
	<input checked="" type="radio"/>	<input type="radio"/>
	<input type="radio"/>	<input type="radio"/>

Modes	Restrictions Apply To:	No Restrictions
Manual	<input checked="" type="radio"/>	<input type="radio"/>
	<input checked="" type="radio"/>	<input type="radio"/>
	<input type="radio"/>	<input type="radio"/>
	<input type="radio"/>	<input type="radio"/>
	<input type="radio"/>	<input type="radio"/>

To Stage

From Stage	0	1	2	3	4	5
0						
1						
2		0				
3						
4						
5						

Works Order : 5790/484/3
 EM Number : 66221
 Engineer : marco Gmys
 Intersection : B2068 Old Dover / St Lawrence Rd, Canterbury. 06/061

Stages - Prohibited, Alternative, Ignored Moves

Stages - Prohibited, Alternative, Ignored Moves

Sets

1

2

3

4

Modes	Restrictions Apply To:	No Restrictions
Urban Traffic Control	<input checked="" type="radio"/>	<input type="radio"/>
Cableless Linking	<input checked="" type="radio"/>	<input type="radio"/>
	<input checked="" type="radio"/>	<input type="radio"/>
	<input checked="" type="radio"/>	<input type="radio"/>
	<input checked="" type="radio"/>	<input type="radio"/>
	<input type="radio"/>	<input type="radio"/>

Modes	Restrictions Apply To:	No Restrictions
	<input checked="" type="radio"/>	<input type="radio"/>
	<input checked="" type="radio"/>	<input type="radio"/>
	<input type="radio"/>	<input type="radio"/>
	<input type="radio"/>	<input type="radio"/>
	<input type="radio"/>	<input type="radio"/>

To Stage

	0	1	2	3	4	5
0						
1	P					
2		0				
3	P					
4	P					
5	P					

Works Order : 5790/484/3
 EM Number : 66221
 Engineer : marco Gmys
 Intersection : B2068 Old Dover / St Lawrence Rd, Canterbury. 06/061

Stages - Prohibited, Alternative, Ignored Moves

Stages - Prohibited, Alternative, Ignored Moves

Sets

1

2

3

4

Modes	Restrictions Apply To:	No Restrictions
	<input checked="" type="radio"/>	<input type="radio"/>
	<input checked="" type="radio"/>	<input type="radio"/>
Vehicle Actuated	<input checked="" type="radio"/>	<input type="radio"/>
Hurry Call	<input checked="" type="radio"/>	<input type="radio"/>
Fixed Time	<input checked="" type="radio"/>	<input type="radio"/>
	<input type="radio"/>	<input type="radio"/>

Modes	Restrictions Apply To:	No Restrictions
	<input checked="" type="radio"/>	<input type="radio"/>
Priority	<input checked="" type="radio"/>	<input type="radio"/>
	<input type="radio"/>	<input type="radio"/>
	<input type="radio"/>	<input type="radio"/>
	<input type="radio"/>	<input type="radio"/>

To Stage

	0	1	2	3	4	5
0						
1	X					
2		0				
3	X					
4	X					
5	X					

Stage Internal Demands/Pedestrian Window Times

Stage Internal Demands/Pedestrian Window Times

Start-up Vehicle Responsive Demands

0	<input type="checkbox"/>	1	<input type="checkbox"/>	2	<input type="checkbox"/>	3	<input type="checkbox"/>	4	<input type="checkbox"/>	5	<input type="checkbox"/>	<input type="checkbox"/>	<input type="checkbox"/>	<input type="checkbox"/>	<input type="checkbox"/>	<input type="checkbox"/>	<input type="checkbox"/>	<input type="checkbox"/>	<input type="checkbox"/>	<input type="checkbox"/>	<input type="checkbox"/>
	<input type="checkbox"/>		<input type="checkbox"/>		<input type="checkbox"/>		<input type="checkbox"/>		<input type="checkbox"/>		<input type="checkbox"/>		<input type="checkbox"/>		<input type="checkbox"/>		<input type="checkbox"/>		<input type="checkbox"/>		<input type="checkbox"/>

Demands Inserted When Leaving Manual and Fixed Time Modes

0	<input type="checkbox"/>	1	<input type="checkbox"/>	2	<input type="checkbox"/>	3	<input type="checkbox"/>	4	<input type="checkbox"/>	5	<input type="checkbox"/>	<input type="checkbox"/>	<input type="checkbox"/>	<input type="checkbox"/>	<input type="checkbox"/>	<input type="checkbox"/>	<input type="checkbox"/>	<input type="checkbox"/>	<input type="checkbox"/>	<input type="checkbox"/>	<input type="checkbox"/>
	<input type="checkbox"/>		<input type="checkbox"/>		<input type="checkbox"/>		<input type="checkbox"/>		<input type="checkbox"/>		<input type="checkbox"/>		<input type="checkbox"/>		<input type="checkbox"/>		<input type="checkbox"/>		<input type="checkbox"/>		<input type="checkbox"/>

Unlatched Demands that Start Maximum Timers

0	<input checked="" type="checkbox"/>	1	<input checked="" type="checkbox"/>	2	<input checked="" type="checkbox"/>	3	<input checked="" type="checkbox"/>	4	<input checked="" type="checkbox"/>	5	<input checked="" type="checkbox"/>	<input type="checkbox"/>	<input type="checkbox"/>	<input type="checkbox"/>	<input type="checkbox"/>	<input type="checkbox"/>	<input type="checkbox"/>	<input type="checkbox"/>	<input type="checkbox"/>	<input type="checkbox"/>	<input type="checkbox"/>
	<input type="checkbox"/>		<input type="checkbox"/>		<input type="checkbox"/>		<input type="checkbox"/>		<input type="checkbox"/>		<input type="checkbox"/>		<input type="checkbox"/>		<input type="checkbox"/>		<input type="checkbox"/>		<input type="checkbox"/>		<input type="checkbox"/>

Window Times

0	1	2	3	4	5	6	7	8	9	10	11	12	13	14	15
<input type="text" value="0"/>	<input type="text" value="0"/>	<input type="text" value="0"/>	<input type="text" value="0"/>	<input type="text" value="0"/>	<input type="text" value="0"/>										
16	17	18	19	20	21	22	23	24	25	26	27	28	29	30	31

Exceptional Stages

<input type="checkbox"/>	<input type="checkbox"/>	<input type="checkbox"/>	<input type="checkbox"/>	<input type="checkbox"/>	<input type="checkbox"/>	<input type="checkbox"/>	<input type="checkbox"/>	<input type="checkbox"/>	<input type="checkbox"/>	<input type="checkbox"/>	<input type="checkbox"/>	<input type="checkbox"/>	<input type="checkbox"/>	<input type="checkbox"/>	<input type="checkbox"/>
<input type="checkbox"/>	<input type="checkbox"/>	<input type="checkbox"/>	<input type="checkbox"/>	<input type="checkbox"/>	<input type="checkbox"/>	<input type="checkbox"/>	<input type="checkbox"/>	<input type="checkbox"/>	<input type="checkbox"/>	<input type="checkbox"/>	<input type="checkbox"/>	<input type="checkbox"/>	<input type="checkbox"/>	<input type="checkbox"/>	<input type="checkbox"/>

Works Order : 5790/484/3
 EM Number : 66221
 Engineer : marco Gmys
 Intersection : B2068 Old Dover / St Lawrence Rd, Canterbury. 06/061

Fixed Time

Fixed Time

Stage Moves & Times (Not Fixed Time to Current Max)

Current Stage	0	1	2	3	4	5	6	7
Next Stage								
Time								
Current Stage	8	9	10	11	12	13	14	15
Next Stage								
Time								
Current Stage	16	17	18	19	20	21	22	23
Next Stage								
Time								
Current Stage	24	25	26	27	28	29	30	31
Next Stage								
Time								

Phases Demanded and Extended under Fixed Time to Current Max.

	A	B	C	D	E	F	G	H	I	J	K	L	M	N	O	P
Demand	<input checked="" type="checkbox"/>	<input checked="" type="checkbox"/>	<input checked="" type="checkbox"/>	<input checked="" type="checkbox"/>	<input checked="" type="checkbox"/>	<input type="checkbox"/>	<input type="checkbox"/>	<input type="checkbox"/>	<input type="checkbox"/>	<input checked="" type="checkbox"/>	<input checked="" type="checkbox"/>	<input type="checkbox"/>	<input type="checkbox"/>	<input type="checkbox"/>	<input type="checkbox"/>	<input type="checkbox"/>
Extend	<input checked="" type="checkbox"/>	<input checked="" type="checkbox"/>	<input checked="" type="checkbox"/>	<input checked="" type="checkbox"/>	<input checked="" type="checkbox"/>	<input type="checkbox"/>	<input type="checkbox"/>	<input type="checkbox"/>	<input type="checkbox"/>	<input type="checkbox"/>	<input type="checkbox"/>	<input type="checkbox"/>	<input type="checkbox"/>	<input type="checkbox"/>	<input type="checkbox"/>	<input type="checkbox"/>
	Q	R	S	T	U	V	W	X	Y	Z	A2	B2	C2	D2	E2	F2
Demand	<input type="checkbox"/>	<input type="checkbox"/>	<input type="checkbox"/>	<input type="checkbox"/>	<input type="checkbox"/>	<input type="checkbox"/>	<input type="checkbox"/>	<input type="checkbox"/>	<input type="checkbox"/>	<input type="checkbox"/>	<input type="checkbox"/>	<input type="checkbox"/>	<input type="checkbox"/>	<input type="checkbox"/>	<input type="checkbox"/>	<input type="checkbox"/>
Extend	<input type="checkbox"/>	<input type="checkbox"/>	<input type="checkbox"/>	<input type="checkbox"/>	<input type="checkbox"/>	<input type="checkbox"/>	<input type="checkbox"/>	<input type="checkbox"/>	<input type="checkbox"/>	<input type="checkbox"/>	<input type="checkbox"/>	<input type="checkbox"/>	<input type="checkbox"/>	<input type="checkbox"/>	<input type="checkbox"/>	<input type="checkbox"/>

UTC General Data

UTC General Data

Type of UTC

106

316

Integral OTU Address

Number of Control Words

Number of Reply Words

Controller to respond to TC bit.

Introduction of UTC to be disabled by Priority and LR

Non UTC RTC synchronisation input name

RTC Synchronisation Times

Clock Synchronise Time (UTC TS input)

Day

Time

Clock Confirm Time (UTC RT output)

Day

Time

Works Order : 5790/484/3
 EM Number : 66221
 Engineer : marco Gmys
 Intersection : B2068 Old Dover / St Lawrence Rd, Canterbury. 06/061

UTC Control and Reply Data Format

UTC Control and Reply Data Format

	Bit 1	Bit 2	Bit 3	Bit 4	Bit 5	Bit 6	Bit 7	Bit 8
Control Words								
Word 1	F1	#F2	#F3	#F4	#F5	D2	D3	D4
Word 2	D5	DX1	TS					
Word 3								
Word 4								
Reply Words								
Word 1	G1	G2	G3	G4	G5	DR2	DR3	DR4
Word 2	DR5	DF	CCT	SP1	RR	LF1	LF2	BD1
Word 3	BD2	BD3	BD4	CC				
Word 4								
Word 5								
Word 6								
Word 7								
Word 8								
Word 9								
Word 10								
Word 11								
Word 12								
Word 13								
Word 14								

UTC Phase Demand and Extend Definitions

UTC Demand and Extend Definitions

Demands

For Unlatched demands, precede the name with a #.
 Conditioning MUST be used to specify unlatched demands.

Phase	Demand 1	Demand 2	Demand 3	Demand 4
A	DX1			
B	DX1	D4		
C	DX1	D2		
D	DX1			
E	DX1	D5		
F				
G				
H				
I				
J	DX1	D3		
K	DX1	D3		

Phases A to P

Extensions

DX1			
DX1	D4		
DX1	D2		
DX1			
DX1	D5		

UTC Stage and Mode Data Definitions

UTC Stage and Mode Data Definitions

Stage	Force Bit	Green Confirm Bit	Demand Confirm Bit	Stage	Force Bit	Green Confirm Bit	Demand Confirm Bit
0				16			
1	F1	G1		17			
2	#F2	G2	DR2	18			
3	#F3	G3	DR3	19			
4	#F4	G4	DR4	20			
5	#F5	G5	DR5	21			
6				22			
7				23			
8				24			
9				25			
10				26			
11				27			
12				28			
13				29			
14				30			
15				31			

Mode Data Definitions

Manual Mode Operative:
 G1/G2 RR

Manual Mode Selected:
 G1/G2 RR

No Lamp Power, or Lamps Off due to RLM or Part Time:
 G1/G2

Detector Fault:
 DF

Normal NOT selected on the Manual Panel:
 G1/G2 RR

RR Button Selected:
 G1/G2 RR

If UTC Reply Confirms are required for a Controller Fault (CF) OR for separate MC and RR replies, Conditioning must be used.

MTC - Time Switch Parameters

MTC - Time Switch Parameters

	Type	Event		Type	Event
0	Alternate Max	MAXSETB	16	No Action	
1	Alternate Max	MAXSETC	17	No Action	
2	Alternate Max	MAXSETD	18	No Action	
3	Alternate DFM	ALTDFMB	19	No Action	
4	Alternate DFM	ALTDFMC	20	No Action	
5	Alternate DFM	ALTDFMD	21	No Action	
6	No Action		22	No Action	
7	No Action		23	No Action	
8	No Action		24	No Action	
9	No Action		25	No Action	
10	No Action		26	No Action	
11	No Action		27	No Action	
12	No Action		28	No Action	
13	No Action		29	No Action	
14	No Action		30	No Action	
15	No Action		31	No Action	

Works Order : 5790/484/3
EM Number : 66221
Engineer : marco Gmys
Intersection : B2068 Old Dover / St Lawrence Rd, Canterbury. 06/061

MTC - Time Switch Parameters Array

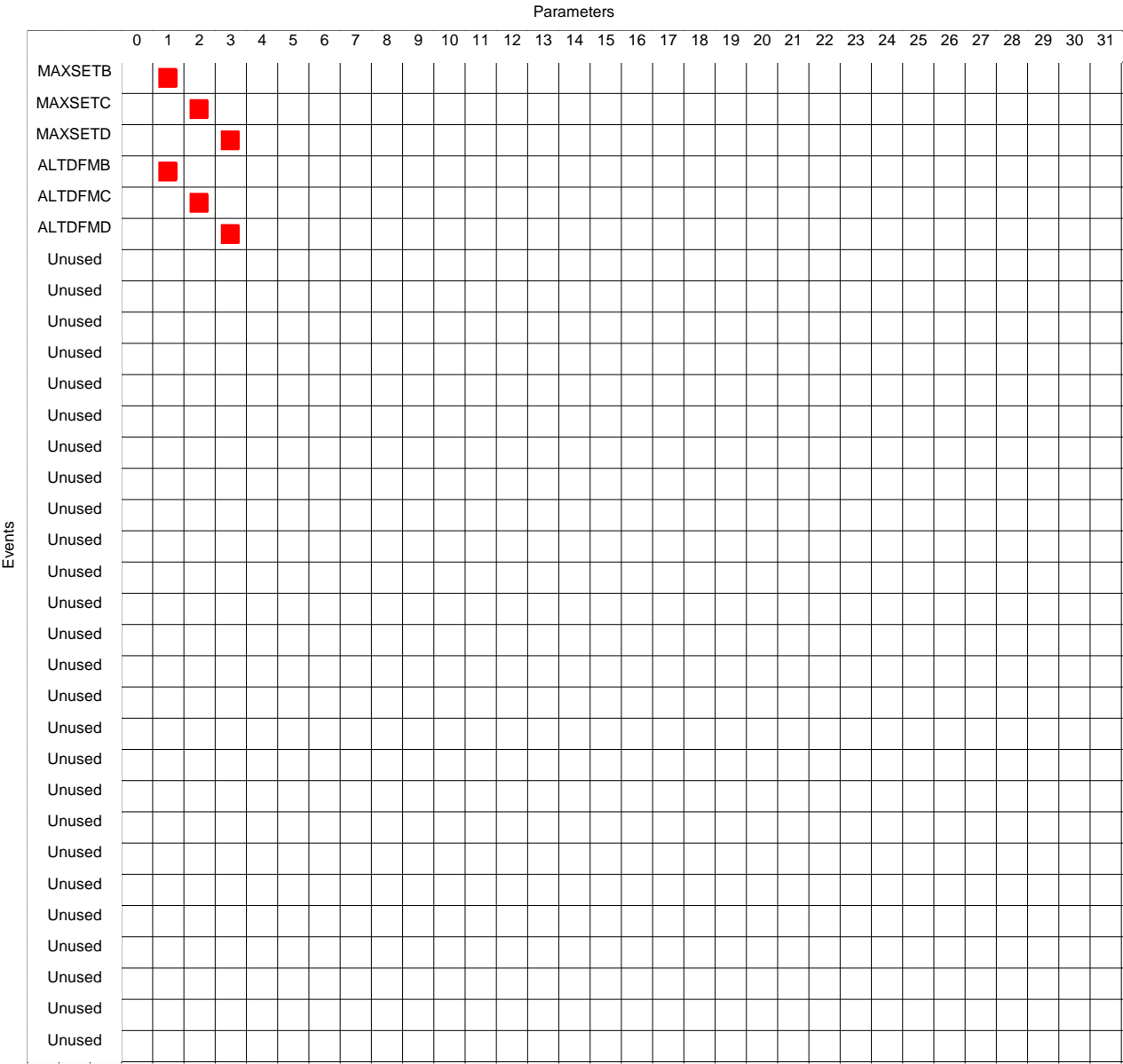

Works Order : 5790/484/3
EM Number : 66221
Engineer : marco Gmys
Intersection : B2068 Old Dover / St Lawrence Rd, Canterbury. 06/061

MTC - Day Type

MTC - Day Type							
No.	Mon	Tue	Wed	Thu	Fri	Sat	Sun
0	<input type="checkbox"/>	<input type="checkbox"/>	<input type="checkbox"/>	<input type="checkbox"/>	<input type="checkbox"/>	<input checked="" type="checkbox"/>	<input type="checkbox"/>
1	<input type="checkbox"/>	<input type="checkbox"/>	<input type="checkbox"/>	<input type="checkbox"/>	<input type="checkbox"/>	<input type="checkbox"/>	<input checked="" type="checkbox"/>
2	<input checked="" type="checkbox"/>	<input type="checkbox"/>	<input type="checkbox"/>	<input type="checkbox"/>	<input type="checkbox"/>	<input type="checkbox"/>	<input type="checkbox"/>
3	<input type="checkbox"/>	<input checked="" type="checkbox"/>	<input type="checkbox"/>	<input type="checkbox"/>	<input type="checkbox"/>	<input type="checkbox"/>	<input type="checkbox"/>
4	<input type="checkbox"/>	<input type="checkbox"/>	<input checked="" type="checkbox"/>	<input type="checkbox"/>	<input type="checkbox"/>	<input type="checkbox"/>	<input type="checkbox"/>
5	<input type="checkbox"/>	<input type="checkbox"/>	<input type="checkbox"/>	<input checked="" type="checkbox"/>	<input type="checkbox"/>	<input type="checkbox"/>	<input type="checkbox"/>
6	<input type="checkbox"/>	<input type="checkbox"/>	<input type="checkbox"/>	<input type="checkbox"/>	<input checked="" type="checkbox"/>	<input type="checkbox"/>	<input type="checkbox"/>
7	<input checked="" type="checkbox"/>	<input checked="" type="checkbox"/>	<input checked="" type="checkbox"/>	<input checked="" type="checkbox"/>	<input checked="" type="checkbox"/>	<input checked="" type="checkbox"/>	<input checked="" type="checkbox"/>
8	<input checked="" type="checkbox"/>	<input checked="" type="checkbox"/>	<input checked="" type="checkbox"/>	<input checked="" type="checkbox"/>	<input checked="" type="checkbox"/>	<input type="checkbox"/>	<input checked="" type="checkbox"/>
9	<input checked="" type="checkbox"/>	<input checked="" type="checkbox"/>	<input checked="" type="checkbox"/>	<input checked="" type="checkbox"/>	<input checked="" type="checkbox"/>	<input type="checkbox"/>	<input type="checkbox"/>
10	<input type="checkbox"/>	<input type="checkbox"/>	<input type="checkbox"/>	<input type="checkbox"/>	<input type="checkbox"/>	<input type="checkbox"/>	<input type="checkbox"/>
11	<input type="checkbox"/>	<input type="checkbox"/>	<input type="checkbox"/>	<input type="checkbox"/>	<input type="checkbox"/>	<input type="checkbox"/>	<input type="checkbox"/>
12	<input type="checkbox"/>	<input type="checkbox"/>	<input type="checkbox"/>	<input type="checkbox"/>	<input type="checkbox"/>	<input type="checkbox"/>	<input type="checkbox"/>
13	<input type="checkbox"/>	<input type="checkbox"/>	<input type="checkbox"/>	<input type="checkbox"/>	<input type="checkbox"/>	<input type="checkbox"/>	<input type="checkbox"/>
14	<input type="checkbox"/>	<input type="checkbox"/>	<input type="checkbox"/>	<input type="checkbox"/>	<input type="checkbox"/>	<input type="checkbox"/>	<input type="checkbox"/>
15	<input type="checkbox"/>	<input type="checkbox"/>	<input type="checkbox"/>	<input type="checkbox"/>	<input type="checkbox"/>	<input type="checkbox"/>	<input type="checkbox"/>

MTC - Timetable

MTC - Timetable

View Timetable Settings

0 - 15
 16 - 31
 32 - 47
 48 - 63

No.	Day Type	Time	Description	Function Code	Plan/Parameter
0	9	07:30:00	Introduce Max Set A	2	0
1	9	09:30:00	Introduce Max Set B	2	1
2	9	15:00:00	Introduce Max Set C	2	2
3	9	18:30:00	Introduce Max Set D	2	3
4	0	07:30:00	Introduce Max Set B	2	1
5	0	19:00:00	Introduce Max Set D	2	3
6	1	08:30:00	Introduce Max Set B	2	1
7	1	18:30:00	Introduce Max Set D	2	3
8	0		Introduce Plan 1	1	1
9	0		Introduce Plan 2	1	2
10	0		Introduce Plan 3	1	3
11	0		Introduce Plan 4	1	4
12	0		Isolate	0	0
13	0		Introduce Plan 2	1	2
14	0		Introduce Plan 4	1	4
15	0		Isolate	0	0

Function Codes:

0 = Isolate From CLF

1 = Introduce a CLF Plan

2 = Introduce a Parameter
(Combination of event switches)

3 = Selects an Individual event
switch to be set

4 = Selects an Individual event
switch to be cleared.

Priority and Emergency Vehicle - General

Priority and Emergency Vehicle - General																							
Unit	Input Name	Type Priority / Emergency		Phase	DFM Time (x10)	Gap Time	DFM Self Reset	Demands Sets				Revertive Demands Sets				Revertive Demands to Start Inhibit Timer Sets							
		P	E					0	1	2	3	0	1	2	3	0	1	2	3				
Unit 0	<input type="text" value="BPA"/>	<input checked="" type="radio"/>	<input type="radio"/>	<input type="text" value="A"/>	<input type="text" value="60"/>	<input type="text" value="4"/>	<input type="text" value="0"/>	<input checked="" type="checkbox"/>	<input checked="" type="checkbox"/>	<input checked="" type="checkbox"/>	<input checked="" type="checkbox"/>	<input type="checkbox"/>	<input type="checkbox"/>	<input type="checkbox"/>	<input type="checkbox"/>	<input type="checkbox"/>	<input type="checkbox"/>	<input type="checkbox"/>	<input type="checkbox"/>	<input type="checkbox"/>	<input type="checkbox"/>	<input type="checkbox"/>	<input type="checkbox"/>
Unit 1	<input type="text" value="BPB"/>	<input checked="" type="radio"/>	<input type="radio"/>	<input type="text" value="B"/>	<input type="text" value="60"/>	<input type="text" value="4"/>	<input type="text" value="0"/>	<input checked="" type="checkbox"/>	<input checked="" type="checkbox"/>	<input checked="" type="checkbox"/>	<input checked="" type="checkbox"/>	<input type="checkbox"/>	<input type="checkbox"/>	<input type="checkbox"/>	<input type="checkbox"/>	<input type="checkbox"/>	<input type="checkbox"/>	<input type="checkbox"/>	<input type="checkbox"/>	<input type="checkbox"/>	<input type="checkbox"/>	<input type="checkbox"/>	<input type="checkbox"/>
Unit 2	<input type="text" value="BPC"/>	<input checked="" type="radio"/>	<input type="radio"/>	<input type="text" value="C"/>	<input type="text" value="60"/>	<input type="text" value="4"/>	<input type="text" value="0"/>	<input checked="" type="checkbox"/>	<input checked="" type="checkbox"/>	<input checked="" type="checkbox"/>	<input checked="" type="checkbox"/>	<input type="checkbox"/>	<input type="checkbox"/>	<input type="checkbox"/>	<input type="checkbox"/>	<input type="checkbox"/>	<input type="checkbox"/>	<input type="checkbox"/>	<input type="checkbox"/>	<input type="checkbox"/>	<input type="checkbox"/>	<input type="checkbox"/>	<input type="checkbox"/>
Unit 3	<input type="text" value="BPD"/>	<input checked="" type="radio"/>	<input type="radio"/>	<input type="text" value="D"/>	<input type="text" value="60"/>	<input type="text" value="4"/>	<input type="text" value="0"/>	<input checked="" type="checkbox"/>	<input checked="" type="checkbox"/>	<input checked="" type="checkbox"/>	<input checked="" type="checkbox"/>	<input type="checkbox"/>	<input type="checkbox"/>	<input type="checkbox"/>	<input type="checkbox"/>	<input type="checkbox"/>	<input type="checkbox"/>	<input type="checkbox"/>	<input type="checkbox"/>	<input type="checkbox"/>	<input type="checkbox"/>	<input type="checkbox"/>	<input type="checkbox"/>
Unit 4	<input type="text"/>	<input checked="" type="radio"/>	<input type="radio"/>	<input type="text"/>	<input type="text" value="30"/>	<input type="text" value="4"/>	<input type="text" value="0"/>	<input checked="" type="checkbox"/>	<input checked="" type="checkbox"/>	<input checked="" type="checkbox"/>	<input checked="" type="checkbox"/>	<input checked="" type="checkbox"/>	<input checked="" type="checkbox"/>	<input checked="" type="checkbox"/>	<input checked="" type="checkbox"/>	<input checked="" type="checkbox"/>	<input checked="" type="checkbox"/>	<input checked="" type="checkbox"/>	<input checked="" type="checkbox"/>	<input checked="" type="checkbox"/>	<input checked="" type="checkbox"/>	<input checked="" type="checkbox"/>	<input checked="" type="checkbox"/>
Unit 5	<input type="text"/>	<input checked="" type="radio"/>	<input type="radio"/>	<input type="text"/>	<input type="text" value="30"/>	<input type="text" value="4"/>	<input type="text" value="0"/>	<input checked="" type="checkbox"/>	<input checked="" type="checkbox"/>	<input checked="" type="checkbox"/>	<input checked="" type="checkbox"/>	<input checked="" type="checkbox"/>	<input checked="" type="checkbox"/>	<input checked="" type="checkbox"/>	<input checked="" type="checkbox"/>	<input checked="" type="checkbox"/>	<input checked="" type="checkbox"/>	<input checked="" type="checkbox"/>	<input checked="" type="checkbox"/>	<input checked="" type="checkbox"/>	<input checked="" type="checkbox"/>	<input checked="" type="checkbox"/>	<input checked="" type="checkbox"/>
Unit 6	<input type="text"/>	<input checked="" type="radio"/>	<input type="radio"/>	<input type="text"/>	<input type="text" value="30"/>	<input type="text" value="4"/>	<input type="text" value="0"/>	<input checked="" type="checkbox"/>	<input checked="" type="checkbox"/>	<input checked="" type="checkbox"/>	<input checked="" type="checkbox"/>	<input checked="" type="checkbox"/>	<input checked="" type="checkbox"/>	<input checked="" type="checkbox"/>	<input checked="" type="checkbox"/>	<input checked="" type="checkbox"/>	<input checked="" type="checkbox"/>	<input checked="" type="checkbox"/>	<input checked="" type="checkbox"/>	<input checked="" type="checkbox"/>	<input checked="" type="checkbox"/>	<input checked="" type="checkbox"/>	<input checked="" type="checkbox"/>
Unit 7	<input type="text"/>	<input checked="" type="radio"/>	<input type="radio"/>	<input type="text"/>	<input type="text" value="30"/>	<input type="text" value="4"/>	<input type="text" value="0"/>	<input checked="" type="checkbox"/>	<input checked="" type="checkbox"/>	<input checked="" type="checkbox"/>	<input checked="" type="checkbox"/>	<input checked="" type="checkbox"/>	<input checked="" type="checkbox"/>	<input checked="" type="checkbox"/>	<input checked="" type="checkbox"/>	<input checked="" type="checkbox"/>	<input checked="" type="checkbox"/>	<input checked="" type="checkbox"/>	<input checked="" type="checkbox"/>	<input checked="" type="checkbox"/>	<input checked="" type="checkbox"/>	<input checked="" type="checkbox"/>	<input checked="" type="checkbox"/>

Inputs From Conditioning

Note:
 Bus Priority Unit values will not be used unless a valid Input Name is specified
 If Bus Unit is to generate a VA demand, then input name must also be specified on VA demands screen

Note:
 Valid values for DFM Self Reset: 1 or 0 for PB800, 0-255 for PB801 and later

Priority - Delays, Unit Inhibits and Associations

Priority - Delays, Unit Inhibits and Associations										
	Delay Time First Second		Priority Units Inhibited 0 1 2 3 4 5 6 7				Associated Priority Units 0 1 2 3 4 5 6 7			
Unit 0			<input checked="" type="checkbox"/> <input type="checkbox"/> <input type="checkbox"/> <input type="checkbox"/> <input type="checkbox"/> <input type="checkbox"/> <input type="checkbox"/> <input type="checkbox"/>				<input type="checkbox"/> <input type="checkbox"/> <input type="checkbox"/> <input type="checkbox"/> <input type="checkbox"/> <input type="checkbox"/> <input type="checkbox"/> <input type="checkbox"/>			
Unit 1			<input type="checkbox"/> <input checked="" type="checkbox"/> <input type="checkbox"/> <input type="checkbox"/> <input type="checkbox"/> <input type="checkbox"/> <input type="checkbox"/> <input type="checkbox"/>				<input type="checkbox"/> <input type="checkbox"/> <input type="checkbox"/> <input type="checkbox"/> <input type="checkbox"/> <input type="checkbox"/> <input type="checkbox"/> <input type="checkbox"/>			
Unit 2			<input type="checkbox"/> <input type="checkbox"/> <input checked="" type="checkbox"/> <input type="checkbox"/> <input type="checkbox"/> <input type="checkbox"/> <input type="checkbox"/> <input type="checkbox"/>				<input type="checkbox"/> <input type="checkbox"/> <input type="checkbox"/> <input type="checkbox"/> <input type="checkbox"/> <input type="checkbox"/> <input type="checkbox"/> <input type="checkbox"/>			
Unit 3			<input type="checkbox"/> <input type="checkbox"/> <input type="checkbox"/> <input checked="" type="checkbox"/> <input type="checkbox"/> <input type="checkbox"/> <input type="checkbox"/> <input type="checkbox"/>				<input type="checkbox"/> <input type="checkbox"/> <input type="checkbox"/> <input type="checkbox"/> <input type="checkbox"/> <input type="checkbox"/> <input type="checkbox"/> <input type="checkbox"/>			
Unit 4			<input type="checkbox"/> <input type="checkbox"/> <input type="checkbox"/> <input type="checkbox"/> <input type="checkbox"/> <input type="checkbox"/> <input type="checkbox"/> <input type="checkbox"/>				<input type="checkbox"/> <input type="checkbox"/> <input type="checkbox"/> <input type="checkbox"/> <input type="checkbox"/> <input type="checkbox"/> <input type="checkbox"/> <input type="checkbox"/>			
Unit 5			<input type="checkbox"/> <input type="checkbox"/> <input type="checkbox"/> <input type="checkbox"/> <input type="checkbox"/> <input type="checkbox"/> <input type="checkbox"/> <input type="checkbox"/>				<input type="checkbox"/> <input type="checkbox"/> <input type="checkbox"/> <input type="checkbox"/> <input type="checkbox"/> <input type="checkbox"/> <input type="checkbox"/> <input type="checkbox"/>			
Unit 6			<input type="checkbox"/> <input type="checkbox"/> <input type="checkbox"/> <input type="checkbox"/> <input type="checkbox"/> <input type="checkbox"/> <input type="checkbox"/> <input type="checkbox"/>				<input type="checkbox"/> <input type="checkbox"/> <input type="checkbox"/> <input type="checkbox"/> <input type="checkbox"/> <input type="checkbox"/> <input type="checkbox"/> <input type="checkbox"/>			
Unit 7			<input type="checkbox"/> <input type="checkbox"/> <input type="checkbox"/> <input type="checkbox"/> <input type="checkbox"/> <input type="checkbox"/> <input type="checkbox"/> <input type="checkbox"/>				<input type="checkbox"/> <input type="checkbox"/> <input type="checkbox"/> <input type="checkbox"/> <input type="checkbox"/> <input type="checkbox"/> <input type="checkbox"/> <input type="checkbox"/>			
Handset Delay Limits										
First Delay Handset Range	Min	Max	Second Delay Handset Range	Min	Max					

Priority Time Sets

Priority Time Sets

Sets

0 2

1 3

Copy Set

Priority Unit	0	1	2	3	4	5	6	7
Maximum time (secs)	30	30	30	30	15	15	15	15
Extension time (secs)	10.0	10.0	10.0	10.0	10.0	10.0	10.0	10.0
Inhibit Time (secs)	120	120	120	120	50	50	50	50

Compensation Times

Priority Units

	A	B	C	D	E	F	G	H	I	J	K
0											
1											
2											
3											
4											
5											
6											
7											

Works Order : 5790/484/3
 EM Number : 66221
 Engineer : marco Gmys
 Intersection : B2068 Old Dover / St Lawrence Rd, Canterbury. 06/061

Priority Time Sets

Priority Time Sets

Sets

0 2

1 3

Copy Set

Priority Unit	0	1	2	3	4	5	6	7
Maximum time (secs)	30	30	30	30	15	15	15	15
Extension time (secs)	10.0	10.0	10.0	10.0	10.0	10.0	10.0	10.0
Inhibit Time (secs)	120	120	120	120	50	50	50	50

Compensation Times

	A	B	C	D	E	F	G	H	I	J	K
0											
1											
2											
3											
4											
5											
6											
7											

Priority Units

Works Order : 5790/484/3
 EM Number : 66221
 Engineer : marco Gmys
 Intersection : B2068 Old Dover / St Lawrence Rd, Canterbury. 06/061

Priority Time Sets

Priority Time Sets

Sets

0 2

1 3

Copy Set

Priority Unit	0	1	2	3	4	5	6	7
Maximum time (secs)	30	30	30	30	15	15	15	15
Extension time (secs)	10.0	10.0	10.0	10.0	10.0	10.0	10.0	10.0
Inhibit Time (secs)	120	120	120	120	50	50	50	50

Compensation Times

	A	B	C	D	E	F	G	H	I	J	K
0											
1											
2											
3											
4											
5											
6											
7											

Priority Units

Priority Time Sets

Priority Time Sets

Sets

0 2

1 3

Copy Set

Priority Unit	0	1	2	3	4	5	6	7
Maximum time (secs)	30	30	30	30	15	15	15	15
Extension time (secs)	10.0	10.0	10.0	10.0	10.0	10.0	10.0	10.0
Inhibit Time (secs)	120	120	120	120	50	50	50	50

Compensation Times

Priority Units

	A	B	C	D	E	F	G	H	I	J	K
0											
1											
2											
3											
4											
5											
6											
7											

Works Order : 5790/484/3
EM Number : 66221
Engineer : marco Gmys
Intersection : B2068 Old Dover / St Lawrence Rd, Canterbury. 06/061

Priority - Allowed and Enforced Demands

Phase

	A	B	C	D	E	F	G	H	I	J	K
0											
1											
2											
3											
4											
5											
6											
7											

Works Order : 5790/484/3
 EM Number : 66221
 Engineer : marco Gmys
 Intersection : B2068 Old Dover / St Lawrence Rd, Canterbury. 06/061

Hurry Call

Hurry Call

Hurry Call	Stage Called	Call Input Name	Cancel Input Name	Confirm Output Name	Delay Time	Hold Time	Prevent Time
0	<input type="text" value="2"/>	<input type="text" value="*SCRT10"/>	<input type="text" value="CANCLHC0"/>	<input type="text"/>	<input type="text" value="0"/>	<input type="text" value="30"/>	<input type="text" value="0"/>
1	<input type="text" value="1"/>	<input type="text" value="*SCRT12"/>	<input type="text"/>	<input type="text"/>	<input type="text" value="15"/>	<input type="text" value="7"/>	<input type="text" value="0"/>
2	<input type="text"/>	<input type="text"/>	<input type="text"/>	<input type="text"/>	<input type="text" value="0"/>	<input type="text" value="0"/>	<input type="text" value="0"/>
3	<input type="text"/>	<input type="text"/>	<input type="text"/>	<input type="text"/>	<input type="text" value="0"/>	<input type="text" value="0"/>	<input type="text" value="0"/>
4	<input type="text"/>	<input type="text"/>	<input type="text"/>	<input type="text"/>	<input type="text" value="0"/>	<input type="text" value="0"/>	<input type="text" value="0"/>
5	<input type="text"/>	<input type="text"/>	<input type="text"/>	<input type="text"/>	<input type="text" value="0"/>	<input type="text" value="0"/>	<input type="text" value="0"/>
6	<input type="text"/>	<input type="text"/>	<input type="text"/>	<input type="text"/>	<input type="text" value="0"/>	<input type="text" value="0"/>	<input type="text" value="0"/>
7	<input type="text"/>	<input type="text"/>	<input type="text"/>	<input type="text"/>	<input type="text" value="0"/>	<input type="text" value="0"/>	<input type="text" value="0"/>

Hurry Call Limit Values

	Min.	Max.
Call Delay	<input type="text" value="0"/>	<input type="text" value="255"/>
Call Hold	<input type="text" value="0"/>	<input type="text" value="255"/>
Call Prevent	<input type="text" value="0"/>	<input type="text" value="255"/>

Works Order : 5790/484/3
 EM Number : 66221
 Engineer : marco Gmys
 Intersection : B2068 Old Dover / St Lawrence Rd, Canterbury. 06/061

Manual Panel

Manual Panel

Stage Buttons and LEDs

Button No.	Title	Called Stage for Stream							
		0	1	2	3	4	5	6	7
0	All Red	<input type="text" value="0"/>							
1	Old Dover Road	<input type="text" value="1"/>							
2	Old Dover Rd SE + RT	<input type="text" value="2"/>							
3	Pedestrians	<input type="text" value="3"/>							
4	St Lawrence	<input type="text" value="4"/>							
5	The Drive	<input type="text" value="5"/>							
6	<input type="text"/>	<input type="text"/>							
7	<input type="text"/>	<input type="text"/>							

General LEDs

	AUX 1	AUX 2	AUX 3	AUX 4 (Hurry Call)	AUX 5 (Higher Priority)
Conditioned	<input type="checkbox"/>	<input checked="" type="checkbox"/>	<input checked="" type="checkbox"/>	<input type="checkbox"/>	<input checked="" type="checkbox"/>

Manual Mode Enable

Always
 When Handset Plugged in (Note 1)
 When 'MND' Command Entered

NOTE:
For this to operate Special Conditioning is required.

General Buttons

	None	SW1	SW2	SW3
Momentary		<input type="checkbox"/>	<input type="checkbox"/>	<input type="checkbox"/>
Dim Override	<input type="radio"/>	<input checked="" type="radio"/>	<input type="radio"/>	<input type="radio"/>
RR	<input checked="" type="radio"/>	<input type="radio"/>	<input type="radio"/>	<input type="radio"/>

Manual Signals On

Immediate Signals On
 As Start-Up

Mode Select Switches Disabled

VA Fixed Time CLF

Works Order : 5790/484/3
 EM Number : 66221
 Engineer : marco Gmys
 Intersection : B2068 Old Dover / St Lawrence Rd, Canterbury. 06/061

Manual Mode - Optional Phases Appearance

Manual Mode - Optional Phases Appearance

	A	B	C	D	E	F	G	H	I	J	K	L	M	N	O	P
Never Appears	<input type="radio"/>	<input type="radio"/>	<input type="radio"/>	<input type="radio"/>	<input type="radio"/>	<input type="radio"/>	<input type="radio"/>	<input type="radio"/>	<input type="radio"/>	<input type="radio"/>	<input type="radio"/>	<input type="radio"/>	<input type="radio"/>	<input type="radio"/>	<input type="radio"/>	<input type="radio"/>
Demand Dependant	<input type="radio"/>	<input type="radio"/>	<input type="radio"/>	<input type="radio"/>	<input type="radio"/>	<input checked="" type="radio"/>	<input checked="" type="radio"/>	<input type="radio"/>	<input type="radio"/>	<input type="radio"/>	<input type="radio"/>	<input type="radio"/>	<input type="radio"/>	<input type="radio"/>	<input type="radio"/>	<input type="radio"/>
Always Appears	<input checked="" type="radio"/>	<input checked="" type="radio"/>	<input checked="" type="radio"/>	<input checked="" type="radio"/>	<input checked="" type="radio"/>	<input type="radio"/>	<input type="radio"/>	<input checked="" type="radio"/>	<input checked="" type="radio"/>	<input checked="" type="radio"/>	<input checked="" type="radio"/>	<input type="radio"/>	<input type="radio"/>	<input type="radio"/>	<input type="radio"/>	<input type="radio"/>
	Q	R	S	T	U	V	W	X	Y	Z	A2	B2	C2	D2	E2	F2
Never Appears	<input type="radio"/>	<input type="radio"/>	<input type="radio"/>	<input type="radio"/>	<input type="radio"/>	<input type="radio"/>	<input type="radio"/>	<input type="radio"/>	<input type="radio"/>	<input type="radio"/>	<input type="radio"/>	<input type="radio"/>	<input type="radio"/>	<input type="radio"/>	<input type="radio"/>	<input type="radio"/>
Demand Dependant	<input type="radio"/>	<input type="radio"/>	<input type="radio"/>	<input type="radio"/>	<input type="radio"/>	<input type="radio"/>	<input type="radio"/>	<input type="radio"/>	<input type="radio"/>	<input type="radio"/>	<input type="radio"/>	<input type="radio"/>	<input type="radio"/>	<input type="radio"/>	<input type="radio"/>	<input type="radio"/>
Always Appears	<input type="radio"/>	<input type="radio"/>	<input type="radio"/>	<input type="radio"/>	<input type="radio"/>	<input type="radio"/>	<input type="radio"/>	<input type="radio"/>	<input type="radio"/>	<input type="radio"/>	<input type="radio"/>	<input type="radio"/>	<input type="radio"/>	<input type="radio"/>	<input type="radio"/>	<input type="radio"/>

Extend All Red - General

Extend All Red - General

Auto Extend to Max

- Part Time
- Emergency Vehicle
- Hurry Call
- LRT
- Priority
- Manual
- Manual Step On
- UTC
- MOVA
- CLF
- VA*
- Fixed Time

All Red Timings

Stream	0	1	2	3	4	5	6	7
Extension Time	<input style="width: 100px;" type="text" value="0.0"/>							
Max Time	<input style="width: 100px;" type="text" value="8"/>							

* Selecting Extend to Max on VA mode will also cause Extend to Max on CLF, UTC and Priority modes.

Detectors Associated with All Red Extension Units

Unit	Associated Detectors							
1	MVD4	CP						
2	MVD4							
3	CP							
4								
5								
6								
7								

The association between detectors and extension units must be performed in special conditioning.

Works Order : 5790/484/3
EM Number : 66221
Engineer : marco Gmys
Intersection : B2068 Old Dover / St Lawrence Rd, Canterbury. 06/061

Extend All Red - Stage To Stage Moves

To Stage

	0	1	2	3	4	5
From Stage 0						
1				1		
2				3		
3						
4						
5				2		

Works Order : 5790/484/3
EM Number : 66221
Engineer : marco Gmys
Intersection : B2068 Old Dover / St Lawrence Rd, Canterbury. 06/061

Extend All Red - Independent Intergreens

Phase Not Affected by Hold

	A	B	C	D	E	F	G	H	I	J	K
A	■										
B		■									
C			■								
D				■							
E					■						
F						■					
G							■				
H								■			
I									■		
J										■	
K											■

Works Order : 5790/484/3
EM Number : 66221
Engineer : marco Gmys
Intersection : B2068 Old Dover / St Lawrence Rd, Canterbury. 06/061

Special Conditioning

```
; USE OF SCRATCH BITS
; -----
; SCRT0
; SCRT1
; SCRT2
; SCRT3
; SCRT4
; SCRT5
; SCRT6
; SCRT7
; SCRT8
; SCRT9
; SCRT10 = REQUEST HURRY CALL 0
; SCRT11 = CONFIRMATION THAT HURRY CALL 0 HAS RUN, SO AS TO ALLOW HURRY CALL 1
; SCRT12 = REQUEST HURRY CALL 1
; SCRT13 =
; SCRT14 =
; SCRT15 =

; HURRY CALL CONDITIONING
; =====

; REQUEST HURRY CALL 0
; -----
CCTO4.CCTO5.NOT(PHASEF).NOT(PHASEG).NOT(CNDTMA21)=SCRT10 ; HURRY CALL 0 IS REQUESTED, BY SCRT10, IF
; BOTH HURRY CALL CALL CANCEL INPUTS ARE TRUE
; AND PHASE F IS NOT GREEN
; AND PHASE G IS NOT GREEN
; AND HURRY CALL PREVENT CONDITIONING TIMER 1
; IS NOT RUNNING

; HURRY CALL 0 PREVENT PERIOD
; -----
IFT HRYSTT1 EQL<1> THN ; IF HURRY CALL 0 IS TIMING REQUEST OR FORCING HURRY MODE
RUN<20> ; REPEATEDLY START CONDITIONING TIMER 0
END

IFT (HRYSTT1 EQL<2>).CNDTER20 THN ; IF HURRY CALL 0 IS TIMING HOLD PERIOD AND CONDITIONING TIMER 0
RUN<21> ; HAS JUST TERMINATED THEN START CONDITIONING TIMER 1
END

; CANCEL HURRY CALL 0
; -----
IFT HRYSTT1 EQL<2> THN ; IF HURRY CALL 0 IS TIMING HOLD PERIOD THEN
IFT (NOT(HC1).NOT(HC2))+LCPHJ+LCPHK) THN ; HURRY CALL 0 IS CANCELLED IF EITHER
TRUE=CANCLHC0 ; LOOPS HC1 AND HC2 ARE BOTH UNOCCUPIED
END ; OR
END ; PHASE J OR PHASE K (F OF G) ARE DEMANDED

; REQUEST HURRY CALL 1
; -----
; HURRY CALL 1 MAY BE ENABLED/ DISABLED BY HANDSET USING THE
; CONDITIONING FACILTIY ENABLE COMMAND "CFE".
; CONTROLLER CFE0 DEFAULT VALUE IS NORMALLY "0" (DISABLED)
; WHEREAS THE REQUIRED DEFAULT STATE FOR HURRY CALL 1 IS ENABLED.
; THEREFORE IN CONDITIONING THE RESULTANT STATE OF CFE0 HAS BEEN INVERTED
```

Works Order : 5790/484/3
EM Number : 66221
Engineer : marco Gmys
Intersection : B2068 Old Dover / St Lawrence Rd, Canterbury. 06/061

Special Conditioning

```
; TO ALLOW THE DEFAULT VALUE OF "0" TO MEAN ENABLED.
;
; TO DISABLE HURRY CALL 1 SET CFE0 TO "1"
; TO ENABLE HURRY CALL 1 SET CFE0 TO "0"
;
IFT NOT(CFE0 EQL<1>) THN      ; IF HURRY CALL 1 CONDITIONING IS ENABLED THEN
IFT HRYSTT1 EQL<2> THN      ; IF HURRY CALL 0 IS TIMING HOLD PERIOD THEN
RUN<22>                      ; REPEATEDLY START CONDITIONING TIMER 2
END

IFT CNDTER22 THN            ; IF CONDITIONING TIMER 2 HAS JUST TERMINATED THEN
TRUE=SCRT11                ; SET SCRATCH BIT SCRT11 TRUE
END

IFT NOT(PREVB).PHASEB.SCRT11 THN ; IF PHASE B HAS JUST GONE TO GREEN AND
TRUE=SCRT12                ; SCRATCH BIT SCRT11 IS TRUE THEN
ELS                        ; SET SCRATCH BIT SCRT12 TRUE
FALSE=SCRT12              ; OTHERWISE SET SCRATCH BIT SCRT12 TO FALSE
END

IFT PHASEA THN            ; IF PHASE A IS AT GREEN THEN
FALSE=SCRT11              ; RESET SCRATCH BIT SCRT11 TO FALSE
END

END

; STAGE 1 REVERSION WITH UNSATISFIED PED DEMAND
;~~~~~
STAGE3.(LCPHJ+LCPHK).(NOT(LCPHB+UCPHB+LCPHC+UCPHC+LCPHE+UCPHE))=+LCPHA ;ALLOW REVERT TO STAGE 1 IF A PED PHASE DEMAND AT I
;STAGE TO STAGE 3.

MAUXSW1=MIL22              ;AUX 1 LED LIT WHEN SWITCH 1 OPERATED ( dimming override )
(MODE0 EQL<6>)=MIL23      ;AUX 2 LED LIT WHEN UTC ACTIVE
(MODE0 EQL<3>)=MIL05      ;AUX 3 LED LIT WHEN RUNNING CLF
(MODE0 EQL<13>)=MIL17     ;BUS PRIORITY LIGHTS HIGHER PRIORITY LED

; CALL / CANCEL UNIT OPERATION
; -----
CCTO0=+LCPHA              ;CALL CANCEL UNIT 0 INSERTS A LATCHED DEMAND FOR PHASE B
CCTO1=+LCPHB

; UTC REPLIES
; =====
LMPON.LPSPRD.SWLMP.S.Not(FLF17).NOT(STAGE1)=G1 ;LAMPS OFF AND STAGE CONFIRMS FOR UTC G1 _G2 BITS
LMPON.LPSPRD.SWLMP.S.Not(FLF17).NOT(STAGE2)=G2

NOT((MODE0 EQL<1>+MODE0 EQL<2>+MODE0 EQL<4>))=RR ;RR BIT REPLIES MANUAL,F.T AND VA MODES

; UTC BUS PRIORITY REPLIES
; -----
NOT(MODE0 EQL<13>)=SP1    ;SP1 BIT REPLIES WHEN IN PRIORITY MODE

NOT(BPA)=BD1             ;BD1 REPLIES WHEN INPUT BPA IS ACTIVE
NOT(BPB)=BD2            ;BD2 REPLIES WHEN INPUT BPB IS ACTIVE
NOT(BPC)=BD3            ;BD3 REPLIES WHEN INPUT BPC IS ACTIVE
NOT(BPD)=BD4            ;BD4 REPLIES WHEN INPUT BPD IS ACTIVE
```

Works Order : 5790/484/3
EM Number : 66221
Engineer : marco Gmys
Intersection : B2068 Old Dover / St Lawrence Rd, Canterbury. 06/061

Special Conditioning

```
NOT(LMPANY0)=LF1 ;ANY LAMP FAIL REPLIES UTC LF1 BIT.
NOT(LMP2RED0)=LF2 ;SECOND RED LAMP FAIL REPLIES UTC LF2 BIT.

; EXTEND ALL RED SPECIAL CONDITIONING FOR UNITS 1 TO 3
; -----
MVD4+MVD4_ext+CP+CP_ext+SSFIX =IGEO1 ; UNIT 1
(MVD4+MVD4_ext+CP+CP_ext+SSFIX)=IGEC1
MVD4+MVD4_ext+SSFIX =IGEO2 ; UNIT 2
MVD4+MVD4_ext+SSFIX =IGEC2
CP+CP_ext+SSFIX =IGEO3 ; UNIT 3
CP+CP_ext+SSFIX =IGEC3

; RTC SYNC CONFIRM SIGNAL
; ~~~~~
; CONFIRM SIGNALS AFTER SYNC TIME AS FOLLOWS -

;SUNDAY----- FOR 3 SECONDS
;MONDAY----- FOR 5 SECONDS
;TUESDAY----- FOR 7 SECONDS
;WEDNESDAY-- FOR 9 SECONDS
;THURSDAY--- FOR 11 SECONDS
;FRIDAY----- FOR 13 SECONDS
;SATURDAY--- FOR 15 SECONDS

IFT 1SCRT254.NOT CC THN
TRUE=1SCRT255
END

1SCRT254.NOT(1SCRT255)=CCT

NOT(MODE0 EQL<8>)=+1SCRT254

NOT((RTCDYS EQL<1>).(RTCSEC GRT<2>))=.1SCRT255 ; RESET FLAG - SUNDAY
NOT((RTCDYS EQL<2>).(RTCSEC GRT<4>))=.1SCRT255 ; RESET FLAG - MONDAY
NOT((RTCDYS EQL<3>).(RTCSEC GRT<6>))=.1SCRT255 ; RESET FLAG - TUESDAY
NOT((RTCDYS EQL<4>).(RTCSEC GRT<8>))=.1SCRT255 ; RESET FLAG - WEDNESDAY
NOT((RTCDYS EQL<5>).(RTCSEC GRT<10>))=.1SCRT255 ; RESET FLAG - THURSDAY
NOT((RTCDYS EQL<6>).(RTCSEC GRT<12>))=.1SCRT255 ; RESET FLAG - FRIDAY
NOT((RTCDYS EQL<0>).(RTCSEC GRT<14>))=.1SCRT255 ; RESET FLAG - SATURDAY
```

Works Order : 5790/484/3
EM Number : 66221
Engineer : marco Gmys
Intersection : B2068 Old Dover / St Lawrence Rd, Canterbury. 06/061

Special Conditioning

```
; EXTERNAL LAMP MONITORING FACILITY
; -----
RF2:.PHASEF=1AUXCMD4          ; DOUBLE RED FAIL SENDS ALL PEDESTRIAN PHASES TO RED
*.PHASEG=1AUXCMDG4

RF2:+LCPHJ=+1WTCTRLF        ; WAIT INDICATORS LIT IF DEMAND EXISTS
*.LCPHK=+1WTCTRLG          ; FOR ASSOCIATED DUMMY PHASE(S) OR IF RF2 PRESENT

FALSE::=.LCPHF              ; REMOVES ALL PEDESTRIAN PHASE DEMANDS UNTIL
*.UCPHF                     ; FOLLOWING BLOCK INSERTS THEM
*.LCPHG
*.UCPHG

PHASEJ.((NOT CNDTMA32)+(NOT RF1)).(NOT RF2)=+UCPHF ; DEMAND REAL PEDESTRIAN PHASE WHEN DUMMY REACHES
; GREEN IF RF1 ABSENT OR AFTER DELAY TIMER IF RF1 PRESENT
; DO NOT DEMAND AT ALL IF RF2 PRESENT

PHASEK.((NOT CNDTMA33)+(NOT RF1)).(NOT RF2)=+UCPHG ; DEMAND REAL PEDESTRIAN PHASE WHEN DUMMY REACHES
; GREEN IF RF1 ABSENT OR AFTER DELAY TIMER IF RF1 PRESENT
; DO NOT DEMAND AT ALL IF RF2 PRESENT

RF2:+LCPHF=PRVPHF          ; PREVENT PEDESTRIAN PHASES FROM APPEARING IF RF2
*.LCPHG=PRVPHG            ; PRESENT OR IF A LATCHED DEMAND EXISTS

IFT (NOT PHASEJ) THN       ; RESET RLMU DELAY TIMERS IF ASSOCIATED DUMMY PHASES
RUN <32>                   ; ARE NOT AT GREEN
END

IFT (NOT PHASEK) THN
RUN <33>
END

(NOT RF2)::=.PRSLMPAF=+UCPHJ ; WAIT LAMP LIT ON REAL PHASE DEMANDS DUMMY PHASE
*.PRSLMPAG=+UCPHK          ; PROVIDING RF2 NOT PRESENT
*.PRSLMPAF=+LCPHJ
*.PRSLMPAG=+LCPHK

(NOT RF2)::=.LCPHJ         ; REMOVE ALL DUMMY PHASE DEMANDS IF RF2 PRESENT
*.UCPHJ
*.LCPHK
*.UCPHK

INC 1SCRTCH30              ; IF THE LMU SIGNALS A RED FAIL
(RF1+RF2).1SCRT241=CABLMP ; FLASH THE DFM LAMP
(NOT(MODE0 EQL <8>)):.LF=1PEDFLF0 ; ANY LAMP FAIL SETS FLF23=1
*.RF1=1PEDFLF1            ; SINGLE RED FAIL SETS FLF23=2
*.RF2=1PEDFLF2            ; DOUBLE RED FAIL SETS FLF23=4
; N.B. MULTIPLE FAILURES COULD GIVE OTHER VALUES

NOT(LF).NOT(RF1)=LF1      ; ANY LAMP FAIL REPLIES LF1
NOT(RF2)=LF2              ; 2ND RED FAIL REPLIES LF2
```

Works Order : 5790/484/3
EM Number : 66221
Engineer : marco Gmys
Intersection : B2068 Old Dover / St Lawrence Rd, Canterbury. 06/061

Special Conditioning

; ADDITIONAL DETECTOR DEMANDS / EXTENSIONS
; ~~~~~
BZ: =+EXOB
* =+EXCB

Special Conditioning Timers

Special Conditioning Timers

Timers

0-31

No	Value	Min	Max	200ms	Description	No	Value	Min	Max	200ms	Description
0		0	255	<input type="checkbox"/>		16		0	255	<input type="checkbox"/>	
1		0	255	<input type="checkbox"/>		17		0	255	<input type="checkbox"/>	
2		0	255	<input type="checkbox"/>		18		0	255	<input type="checkbox"/>	
3		0	255	<input type="checkbox"/>		19		0	255	<input type="checkbox"/>	
4		0	255	<input type="checkbox"/>		20	1	0	255	<input type="checkbox"/>	Timer used to start Timer 21
5		0	255	<input type="checkbox"/>		21	50	0	255	<input type="checkbox"/>	Hurry Call 0 prevent timer
6		0	255	<input type="checkbox"/>		22	1	0	255	<input type="checkbox"/>	Timer used to request Hurry Call 1
7		0	255	<input type="checkbox"/>		23		0	255	<input type="checkbox"/>	
8		0	255	<input type="checkbox"/>		24		0	255	<input type="checkbox"/>	
9		0	255	<input type="checkbox"/>		25		0	255	<input type="checkbox"/>	
10		0	255	<input type="checkbox"/>		26		0	255	<input type="checkbox"/>	
11		0	255	<input type="checkbox"/>		27		0	255	<input type="checkbox"/>	
12		0	255	<input type="checkbox"/>		28		0	255	<input type="checkbox"/>	
13		0	255	<input type="checkbox"/>		29		0	255	<input type="checkbox"/>	
14		0	255	<input type="checkbox"/>		30		0	255	<input type="checkbox"/>	
15		0	255	<input type="checkbox"/>		31		0	255	<input type="checkbox"/>	

Special Conditioning Timers

Special Conditioning Timers

Timers

32-63

No	Value	Min	Max	200ms	Description	No	Value	Min	Max	200ms	Description
32	2	0	255	<input type="checkbox"/>	Phase F RLM delay timer	48		0	255	<input type="checkbox"/>	
33	2	0	255	<input type="checkbox"/>	Phase G RLM delay timer	49		0	255	<input type="checkbox"/>	
34		0	255	<input type="checkbox"/>		50		0	255	<input type="checkbox"/>	
35		0	255	<input type="checkbox"/>		51		0	255	<input type="checkbox"/>	
36		0	255	<input type="checkbox"/>		52		0	255	<input type="checkbox"/>	
37		0	255	<input type="checkbox"/>		53		0	255	<input type="checkbox"/>	
38		0	255	<input type="checkbox"/>		54		0	255	<input type="checkbox"/>	
39		0	255	<input type="checkbox"/>		55		0	255	<input type="checkbox"/>	
40		0	255	<input type="checkbox"/>		56		0	255	<input type="checkbox"/>	
41		0	255	<input type="checkbox"/>		57		0	255	<input type="checkbox"/>	
42		0	255	<input type="checkbox"/>		58		0	255	<input type="checkbox"/>	
43		0	255	<input type="checkbox"/>		59		0	255	<input type="checkbox"/>	
44		0	255	<input type="checkbox"/>		60		0	255	<input type="checkbox"/>	
45		0	255	<input type="checkbox"/>		61		0	255	<input type="checkbox"/>	
46		0	255	<input type="checkbox"/>		62		0	255	<input type="checkbox"/>	
47		0	255	<input type="checkbox"/>		63		0	255	<input type="checkbox"/>	

Works Order : 5790/484/3
EM Number : 66221
Engineer : marco Gmys
Intersection : B2068 Old Dover / St Lawrence Rd, Canterbury. 06/061

Special Instructions

66221

Board	Position	Skt	Port	Type I or O	Line	Cable	Block
CPU	A	X3I	0	I	00 - 07	101	1TBG
CPU	A	X3I	1	I	08 - 15		1TBH
CPU	A	X3O	11	O	88 - 91	105	1TBX
IO1	B	B	2	I	16 - 23	103	1TBJ
IO1	B	E	4	O	32 - 39		1TBK
IO1	B	C	3	I	24 - 31	103	1TBL
IO1	B	D	5	O	40 - 47		1TBM
IO2	C	B	6	I	48 - 55	103	1TBN
IO2	C	E	8	O	64 - 71		1TBP
IO2	C	C	7	I	56 - 63	103	1TBR
IO2	C	D	9	O	72 - 79		1TBS

The socket X3 on the CPU pcb is the double stacked one
X3I = Inner (nearest the board)
X3O = Outer

The Item List is included for reference only.

Works Order : 5790/484/3
 EM Number : 66221
 Engineer : marco Gmys
 Intersection : B2068 Old Dover / St Lawrence Rd, Canterbury. 06/061

Special Instructions

ST800 CONTROLLER ITEMS LIST SHEET 1 (*I*L*)

ITEM	DRAWING NUMBER	DESCRIPTION	QTY	TOT	REMARKS
1					
2	667/1/27000/001	Cabinet 8 Phase wired 16 Phase		1	
3	667/1/27000/002	Cabinet 24 Phase wired 32 Phase			
4	667/1/27001/001	Rack 8 Phase wired 16 Phase			
5	667/1/27001/002	Rack 24 Phase wired 32 Phase			
6					
7					
8					
9					
10					
11					
12					
13					
14					
15					
16					
17					
18					
19					
20					
21					
22					
23					
24	667/1/27002/000	Lamp Switch Kit 8 Phase			
25	667/1/27003/000	I/O Kit		2	
26	667/1/27005/000	SDE Facility Kit			
27	667/1/27004/000	Integral OTU Kit			
28					
29					
30					
31					
32					
33					
34					
35					
36					
37					
38					
39	667/1/16274/174	Configuration Eprom (Issue 4. 0)		1	
40					

Note 1:
 Please refer to special
 instruction pages for
 additional information on
 items marked with an '*'.

Works Order : 5790/484/3
 EM Number : 66221
 Engineer : marco Gmys
 Intersection : B2068 Old Dover / St Lawrence Rd, Canterbury. 06/061

Special Instructions

ST800 CONTROLLER ITEMS LIST SHEET 2 (*I*L*)

ITEM	DRAWING NUMBER	DESCRIPTION	QTY	TOT	REMARKS
41					
42	667/1/27056/001	Manual Panel Assy (Intersection Cont)			
43	667/1/27056/010	Manual Panel Assy (Sigs on/off)			
44	667/1/27056/000	Manual Panel Blanking Kit			
45					
46					
47					
48					
49					
50					
51					
52	667/7/25171/000	Current Transformer			
53					
54					
55					
56					
57					
58					
59					
60					
61	667/1/27000/101	Cabinet Export 8 Phase wired 16 Phase			
62	667/1/27000/102	Cabinet Export 24 Phase wired 32 Phase			
63	667/1/27001/101	Rack Export 8 Phase wired 16 Phase			
64	667/1/27001/102	Rack Export 24 Phase wired 32 Phase			
65	667/1/27002/100	Export Lamp Switch Kit			
66	667/1/27084/001	Dimming Assembly (1.5KVA)(Fit Std UK)			
67	667/1/27084/002	Dimming Assembly (2.0KVA)			
68	667/1/27084/003	Dimming Assembly (3.0KVA)			
69	667/1/27130/000	30A Controller Kit			
70					
71	667/1/27001/310	ST800 SE Export Rack up to 8 Phase			
72	667/1/27223/003	ST800 SE 8 Phase Driver No LMU			
73	667/1/27223/403	ST800 SE 4 Phase Driver No LMU			
74					
75					
76					
77	667/1/27000/301	ST800 P In a Cabinet 4Ph 1 Stream PED			
78	667/1/27012/000	PED 2nd Stream Kit for ST800 P			
79	667/1/27001/300	ST800 P Rack Only 4Ph 1 Stream PED			

Note 2:
 Ancillary Processor PLD
 Variants
 101 OTU & LMU
 102 OTU Only
 103 LMU Only
 104 OTU & LMU + Up/Download
 105 OUT Only + Up/DownLoad
 NB Controller Has built in LMU
 So LMU on Ancillary Processor
 Not required included for info
 only.

Note 3:
 Fit Current Transformer
 starting from position
 TLB/z/16 on the first phase
 driver PCB. if more than 3
 sensors are called up fit the
 4th sensor to the second
 Phases driver PCB, and so on
 until all sensors have been
 used up.
 TLB/b/14 - 1st sensor terminal
 TLB/z/16 - 2nd sensor terminal
 TLB/z/14 - 3rd sensor terminal
 TLB/z/12 - 4th sensor terminal
 TLB/z/12 - 4th sensor terminal
 TLB/z/12 - 4th sensor terminal

Works Order : 5790/484/3
EM Number : 66221
Engineer : marco Gmys
Intersection : B2068 Old Dover / St Lawrence Rd, Canterbury. 06/061

Special Instructions

Configuration Complexity Number is 209

Works Order : 5790/484/3
EM Number : 66221
Engineer : marco Gmys
Intersection : B2068 Old Dover / St Lawrence Rd, Canterbury. 06/061

Special Instructions

LAMP MONITORING

=====

Lamp monitoring is provided by an external Microsense I2LM unit. Therefore the controllers lamp monitoring facilities are not being used and the red lamp monitoring functions are provided through special conditioning as described below:-

Dummy phase(s) K and L are duplicate of pedestrian phase(s) F and G.

Any timing changes made to the real phase MUST be duplicated on the dummy phase.

Note that the dummy phase does not need any leaving intergreens.

The real ped phase is configured with a type 2 appearance code so conditioning can control when it appears and for this reason the PHD handset command MUST NOT be used for ped phase(s) F or G or J as although the stage will not appear

Under normal operation when the dummy phase goes to green it will demand the real phase which will then go straight to green. However if a 1st red lamp failure exists the demand is delayed by a PIR timer to give the extra intergreen. When a 2nd red lamp failure exists the demand will never occur. If a 2nd red lamp failure occurs during the ped green the real phase will be terminated once it's minimum green time has expired.

Lighting wait indicators and flashing the DFM lamp will operate as normal except that a DFM fault will cause the flashing to cease.

Lamp failure indications from the Microsense I2LM do not set the normal fault log flags so the special pedestrian fault flag (FLF23) has been used instead.

FLF23=1 indicates any lamp fail.

FLF23=2 indicates a 1st red lamp failure.

FLF23=4 indicates a 2nd red lamp failure.

Multiple failures will give a combination of these values, therefore it is easier to read if displayed in binary.

The I2LM fault outputs may be returned via the OTU to provide LF1 and LF2 replies.

I2LM CONNECTIONS

=====

Connect any lamp fail output to :LF 1TBR/6 - I/P61 & input common.

Connect 1st red lamp failure output to :RF1 1TBR/7 - I/P62 & input common.

Connect 2nd red lamp failure output to :RF2 1TBR/8 - I/P63 & input common.

NB. These outputs MUST be open circuit for active.

Works Order : 5790/484/3
EM Number : 66221
Engineer : marco Gmys
Intersection : B2068 Old Dover / St Lawrence Rd, Canterbury. 06/061

Call Cancel

Call Cancel

Unit No.	Input Name	Call Delay	Cancel Delay	Phase Demanded (Unlatched Demand)
0	AP	3	0	
1	BZ	3	0	
2	CP	3	2	C
3	EP	3	0	E
4	HC1	15	0	
5	HC2	15	0	
6		0	0	
7		0	0	

Inputs and Outputs

Inputs and Outputs

Port Number & Type

Enable Signal Required
 Check boxes

Port:

Inputs & Outputs

	DET No	Bit No	Type I or O	Name	Req'd	BP	Inv	U/D	Misc	DFM	DFM Group	Ext time	Phs	UTC	SDE	Pri	HC	CC	IG	UD	LRT	Term Block	Terminal No	
<input type="radio"/>	0	0	I	AX	<input checked="" type="checkbox"/>	<input type="checkbox"/>	<input type="checkbox"/>	<input type="checkbox"/>	<input type="checkbox"/>	A	0	0.0	<input checked="" type="checkbox"/>	<input type="checkbox"/>	<input type="checkbox"/>	<input type="checkbox"/>	<input type="checkbox"/>	<input type="checkbox"/>	<input type="checkbox"/>	<input type="checkbox"/>	<input type="checkbox"/>	<input type="checkbox"/>	1TBG	1
<input type="radio"/>	1	1	I	AY	<input checked="" type="checkbox"/>	<input type="checkbox"/>	<input type="checkbox"/>	<input type="checkbox"/>	<input type="checkbox"/>	A	0	0.0	<input checked="" type="checkbox"/>	<input type="checkbox"/>	<input type="checkbox"/>	<input type="checkbox"/>	<input type="checkbox"/>	<input type="checkbox"/>	<input type="checkbox"/>	<input type="checkbox"/>	<input type="checkbox"/>	<input type="checkbox"/>	1TBG	2
<input type="radio"/>	2	2	I	AZ	<input checked="" type="checkbox"/>	<input type="checkbox"/>	<input type="checkbox"/>	<input type="checkbox"/>	<input type="checkbox"/>	A	0	0.0	<input checked="" type="checkbox"/>	<input type="checkbox"/>	<input type="checkbox"/>	<input type="checkbox"/>	<input type="checkbox"/>	<input type="checkbox"/>	<input type="checkbox"/>	<input type="checkbox"/>	<input type="checkbox"/>	<input type="checkbox"/>	1TBG	3
<input type="radio"/>	3	3	I	AP	<input checked="" type="checkbox"/>	<input type="checkbox"/>	<input type="checkbox"/>	<input type="checkbox"/>	<input type="checkbox"/>	A	0	0.0	<input type="checkbox"/>	<input type="checkbox"/>	<input type="checkbox"/>	<input type="checkbox"/>	<input type="checkbox"/>	<input checked="" type="checkbox"/>	<input type="checkbox"/>	<input type="checkbox"/>	<input type="checkbox"/>	<input type="checkbox"/>	1TBG	4
<input type="radio"/>	4	4	I	BX	<input checked="" type="checkbox"/>	<input type="checkbox"/>	<input type="checkbox"/>	<input checked="" type="checkbox"/>	<input type="checkbox"/>	A	0	0.0	<input checked="" type="checkbox"/>	<input type="checkbox"/>	<input type="checkbox"/>	<input type="checkbox"/>	<input type="checkbox"/>	<input type="checkbox"/>	<input type="checkbox"/>	<input type="checkbox"/>	<input type="checkbox"/>	<input type="checkbox"/>	1TBG	5
<input type="radio"/>	5	5	I	BXu	<input checked="" type="checkbox"/>	<input type="checkbox"/>	<input type="checkbox"/>	<input type="checkbox"/>	<input type="checkbox"/>	I	0	0.0	<input type="checkbox"/>	<input type="checkbox"/>	<input type="checkbox"/>	<input type="checkbox"/>	<input type="checkbox"/>	<input type="checkbox"/>	<input type="checkbox"/>	<input type="checkbox"/>	<input checked="" type="checkbox"/>	<input type="checkbox"/>	1TBG	6
<input type="radio"/>	6	6	I	BY	<input checked="" type="checkbox"/>	<input type="checkbox"/>	<input type="checkbox"/>	<input checked="" type="checkbox"/>	<input type="checkbox"/>	A	0	0.0	<input checked="" type="checkbox"/>	<input type="checkbox"/>	<input type="checkbox"/>	<input type="checkbox"/>	<input type="checkbox"/>	<input type="checkbox"/>	<input type="checkbox"/>	<input type="checkbox"/>	<input type="checkbox"/>	<input type="checkbox"/>	1TBG	7
<input type="radio"/>	7	7	I	BYu	<input checked="" type="checkbox"/>	<input type="checkbox"/>	<input type="checkbox"/>	<input type="checkbox"/>	<input type="checkbox"/>	I	0	0.0	<input type="checkbox"/>	<input type="checkbox"/>	<input type="checkbox"/>	<input type="checkbox"/>	<input type="checkbox"/>	<input type="checkbox"/>	<input type="checkbox"/>	<input type="checkbox"/>	<input checked="" type="checkbox"/>	<input type="checkbox"/>	1TBG	8

Add Delete Move Clear Used By

Inputs and Outputs

Inputs and Outputs

Enable Signal Required
 Check boxes

Port Number & Type

Port:

Inputs & Outputs

	DET No	Bit No	Type I or O	Name	Req'd	BP	Inv	U/D	Misc	DFM	DFM Group	Ext time	Phs	UTC	SDE	Pri	HC	CC	IG	UD	LRT	Term Block	Terminal No
<input type="radio"/>	8	0	I	BZ	<input checked="" type="checkbox"/>	<input type="checkbox"/>	<input type="checkbox"/>	<input type="checkbox"/>	<input type="checkbox"/>	A	0	0.0	<input checked="" type="checkbox"/>	<input type="checkbox"/>	<input type="checkbox"/>	<input type="checkbox"/>	<input type="checkbox"/>	<input checked="" type="checkbox"/>	<input type="checkbox"/>	<input type="checkbox"/>	<input type="checkbox"/>	1TBH	1
<input type="radio"/>	9	1	I	CP	<input checked="" type="checkbox"/>	<input type="checkbox"/>	<input type="checkbox"/>	<input type="checkbox"/>	<input type="checkbox"/>	A	0	2.0	<input checked="" type="checkbox"/>	<input type="checkbox"/>	<input type="checkbox"/>	<input type="checkbox"/>	<input type="checkbox"/>	<input checked="" type="checkbox"/>	<input checked="" type="checkbox"/>	<input type="checkbox"/>	<input type="checkbox"/>	1TBH	2
<input type="radio"/>	10	2	I	DX	<input checked="" type="checkbox"/>	<input type="checkbox"/>	<input type="checkbox"/>	<input type="checkbox"/>	<input type="checkbox"/>	A	0	0.0	<input checked="" type="checkbox"/>	<input type="checkbox"/>	<input type="checkbox"/>	<input type="checkbox"/>	<input type="checkbox"/>	<input type="checkbox"/>	<input type="checkbox"/>	<input type="checkbox"/>	<input type="checkbox"/>	1TBH	3
<input type="radio"/>	11	3	I	DY	<input checked="" type="checkbox"/>	<input type="checkbox"/>	<input type="checkbox"/>	<input type="checkbox"/>	<input type="checkbox"/>	A	0	0.0	<input checked="" type="checkbox"/>	<input type="checkbox"/>	<input type="checkbox"/>	<input type="checkbox"/>	<input type="checkbox"/>	<input type="checkbox"/>	<input type="checkbox"/>	<input type="checkbox"/>	<input type="checkbox"/>	1TBH	4
<input type="radio"/>	12	4	I	DZ	<input checked="" type="checkbox"/>	<input type="checkbox"/>	<input type="checkbox"/>	<input type="checkbox"/>	<input type="checkbox"/>	A	0	0.0	<input checked="" type="checkbox"/>	<input type="checkbox"/>	<input type="checkbox"/>	<input type="checkbox"/>	<input type="checkbox"/>	<input type="checkbox"/>	<input type="checkbox"/>	<input type="checkbox"/>	<input type="checkbox"/>	1TBH	5
<input type="radio"/>	13	5	I	EP	<input checked="" type="checkbox"/>	<input type="checkbox"/>	<input type="checkbox"/>	<input type="checkbox"/>	<input type="checkbox"/>	A	1	0.0	<input type="checkbox"/>	<input type="checkbox"/>	<input type="checkbox"/>	<input type="checkbox"/>	<input type="checkbox"/>	<input checked="" type="checkbox"/>	<input type="checkbox"/>	<input type="checkbox"/>	<input type="checkbox"/>	1TBH	6
<input type="radio"/>	14	6	I	HC1	<input checked="" type="checkbox"/>	<input type="checkbox"/>	<input type="checkbox"/>	<input type="checkbox"/>	<input type="checkbox"/>	I	0	0.0	<input type="checkbox"/>	<input type="checkbox"/>	<input type="checkbox"/>	<input type="checkbox"/>	<input type="checkbox"/>	<input checked="" type="checkbox"/>	<input type="checkbox"/>	<input type="checkbox"/>	<input type="checkbox"/>	1TBH	7
<input type="radio"/>	15	7	I	HC2	<input checked="" type="checkbox"/>	<input type="checkbox"/>	<input type="checkbox"/>	<input type="checkbox"/>	<input type="checkbox"/>	I	0	0.0	<input type="checkbox"/>	<input type="checkbox"/>	<input type="checkbox"/>	<input type="checkbox"/>	<input type="checkbox"/>	<input checked="" type="checkbox"/>	<input type="checkbox"/>	<input type="checkbox"/>	<input type="checkbox"/>	1TBH	8

-
-
-
-

Inputs and Outputs

Inputs and Outputs

Enable Signal Required
 Check boxes

Port Number & Type

Port:

3



Inputs & Outputs

	DET No	Bit No	Type I or O	Name	Req'd	BP	Inv	U/D	Misc	DFM	DFM Group	Ext time	Phs	UTC	SDE	Pri	HC	CC	IG	UD	LRT	Term Block	Terminal No	
<input type="radio"/>	24	0	I		<input type="checkbox"/>	<input type="checkbox"/>	<input type="checkbox"/>	<input type="checkbox"/>	<input type="checkbox"/>				<input type="checkbox"/>	<input type="checkbox"/>	<input type="checkbox"/>	<input type="checkbox"/>	<input type="checkbox"/>	<input type="checkbox"/>	<input type="checkbox"/>	<input type="checkbox"/>	<input type="checkbox"/>	<input type="checkbox"/>	1TBL	1
<input type="radio"/>	25	1	I		<input type="checkbox"/>	<input type="checkbox"/>	<input type="checkbox"/>	<input type="checkbox"/>	<input type="checkbox"/>				<input type="checkbox"/>	<input type="checkbox"/>	<input type="checkbox"/>	<input type="checkbox"/>	<input type="checkbox"/>	<input type="checkbox"/>	<input type="checkbox"/>	<input type="checkbox"/>	<input type="checkbox"/>	<input type="checkbox"/>	1TBL	2
<input type="radio"/>	26	2	I		<input type="checkbox"/>	<input type="checkbox"/>	<input type="checkbox"/>	<input type="checkbox"/>	<input type="checkbox"/>				<input type="checkbox"/>	<input type="checkbox"/>	<input type="checkbox"/>	<input type="checkbox"/>	<input type="checkbox"/>	<input type="checkbox"/>	<input type="checkbox"/>	<input type="checkbox"/>	<input type="checkbox"/>	<input type="checkbox"/>	1TBL	3
<input type="radio"/>	27	3	I	CANCLHC0	<input checked="" type="checkbox"/>	<input type="checkbox"/>	<input type="checkbox"/>	<input type="checkbox"/>	<input type="checkbox"/>	N		0.0	<input type="checkbox"/>	<input type="checkbox"/>	<input type="checkbox"/>	<input type="checkbox"/>	<input checked="" type="checkbox"/>	<input type="checkbox"/>	<input type="checkbox"/>	<input type="checkbox"/>	<input type="checkbox"/>	<input type="checkbox"/>	1TBL	4
<input type="radio"/>	28	4	I		<input type="checkbox"/>	<input type="checkbox"/>	<input type="checkbox"/>	<input type="checkbox"/>	<input type="checkbox"/>				<input type="checkbox"/>	<input type="checkbox"/>	<input type="checkbox"/>	<input type="checkbox"/>	<input type="checkbox"/>	<input type="checkbox"/>	<input type="checkbox"/>	<input type="checkbox"/>	<input type="checkbox"/>	<input type="checkbox"/>	1TBL	5
<input type="radio"/>	29	5	I		<input type="checkbox"/>	<input type="checkbox"/>	<input type="checkbox"/>	<input type="checkbox"/>	<input type="checkbox"/>				<input type="checkbox"/>	<input type="checkbox"/>	<input type="checkbox"/>	<input type="checkbox"/>	<input type="checkbox"/>	<input type="checkbox"/>	<input type="checkbox"/>	<input type="checkbox"/>	<input type="checkbox"/>	<input type="checkbox"/>	1TBL	6
<input type="radio"/>	30	6	I		<input type="checkbox"/>	<input type="checkbox"/>	<input type="checkbox"/>	<input type="checkbox"/>	<input type="checkbox"/>				<input type="checkbox"/>	<input type="checkbox"/>	<input type="checkbox"/>	<input type="checkbox"/>	<input type="checkbox"/>	<input type="checkbox"/>	<input type="checkbox"/>	<input type="checkbox"/>	<input type="checkbox"/>	<input type="checkbox"/>	1TBL	7
<input type="radio"/>	31	7	I		<input type="checkbox"/>	<input type="checkbox"/>	<input type="checkbox"/>	<input type="checkbox"/>	<input type="checkbox"/>				<input type="checkbox"/>	<input type="checkbox"/>	<input type="checkbox"/>	<input type="checkbox"/>	<input type="checkbox"/>	<input type="checkbox"/>	<input type="checkbox"/>	<input type="checkbox"/>	<input type="checkbox"/>	<input type="checkbox"/>	1TBL	8

Add

Delete

Move

Clear Used By

Inputs and Outputs

Inputs and Outputs

Enable Signal Required
 Check boxes

Port Number & Type

Port:

6



Inputs & Outputs

	DET No	Bit No	Type I or O	Name	Req'd	BP	Inv	U/D	Misc	DFM	DFM Group	Ext time	Phs	UTC	SDE	Pri	HC	CC	IG	UD	LRT	Term Block	Terminal No
<input type="radio"/>	48	0	I	MVD4	<input checked="" type="checkbox"/>	<input type="checkbox"/>	<input type="checkbox"/>	<input type="checkbox"/>	<input type="checkbox"/>	A	0	0.6	<input type="checkbox"/>	<input type="checkbox"/>	<input type="checkbox"/>	<input type="checkbox"/>	<input type="checkbox"/>	<input type="checkbox"/>	<input checked="" type="checkbox"/>	<input type="checkbox"/>	<input type="checkbox"/>	1TBN	1
<input type="radio"/>	49	1	I	MVD6	<input checked="" type="checkbox"/>	<input type="checkbox"/>	<input type="checkbox"/>	<input type="checkbox"/>	<input type="checkbox"/>	A	1	0.0	<input checked="" type="checkbox"/>	<input type="checkbox"/>	<input type="checkbox"/>	<input type="checkbox"/>	<input type="checkbox"/>	<input type="checkbox"/>	<input type="checkbox"/>	<input type="checkbox"/>	<input type="checkbox"/>	1TBN	2
<input type="radio"/>	50	2	I	PB2F	<input checked="" type="checkbox"/>	<input type="checkbox"/>	<input type="checkbox"/>	<input type="checkbox"/>	<input type="checkbox"/>	A	1	0.0	<input checked="" type="checkbox"/>	<input type="checkbox"/>	<input type="checkbox"/>	<input type="checkbox"/>	<input type="checkbox"/>	<input type="checkbox"/>	<input type="checkbox"/>	<input type="checkbox"/>	<input type="checkbox"/>	1TBN	3
<input type="radio"/>	51	3	I	PB3F	<input checked="" type="checkbox"/>	<input type="checkbox"/>	<input type="checkbox"/>	<input type="checkbox"/>	<input type="checkbox"/>	A	1	0.0	<input checked="" type="checkbox"/>	<input type="checkbox"/>	<input type="checkbox"/>	<input type="checkbox"/>	<input type="checkbox"/>	<input type="checkbox"/>	<input type="checkbox"/>	<input type="checkbox"/>	<input type="checkbox"/>	1TBN	4
<input type="radio"/>	52	4	I	PB4G	<input checked="" type="checkbox"/>	<input type="checkbox"/>	<input type="checkbox"/>	<input type="checkbox"/>	<input type="checkbox"/>	A	1	0.0	<input checked="" type="checkbox"/>	<input type="checkbox"/>	<input type="checkbox"/>	<input type="checkbox"/>	<input type="checkbox"/>	<input type="checkbox"/>	<input type="checkbox"/>	<input type="checkbox"/>	<input type="checkbox"/>	1TBN	5
<input type="radio"/>	53	5	I	PB5G	<input checked="" type="checkbox"/>	<input type="checkbox"/>	<input type="checkbox"/>	<input type="checkbox"/>	<input type="checkbox"/>	A	1	0.0	<input checked="" type="checkbox"/>	<input type="checkbox"/>	<input type="checkbox"/>	<input type="checkbox"/>	<input type="checkbox"/>	<input type="checkbox"/>	<input type="checkbox"/>	<input type="checkbox"/>	<input type="checkbox"/>	1TBN	6
<input type="radio"/>	54	6	I		<input type="checkbox"/>	<input type="checkbox"/>	<input type="checkbox"/>	<input type="checkbox"/>	<input type="checkbox"/>				<input type="checkbox"/>	<input type="checkbox"/>	<input type="checkbox"/>	<input type="checkbox"/>	<input type="checkbox"/>	<input type="checkbox"/>	<input type="checkbox"/>	<input type="checkbox"/>	<input type="checkbox"/>		
<input type="radio"/>	55	7	I	BPA	<input checked="" type="checkbox"/>	<input type="checkbox"/>	<input type="checkbox"/>	<input type="checkbox"/>	<input type="checkbox"/>	I	2	0.0	<input checked="" type="checkbox"/>	<input type="checkbox"/>	<input type="checkbox"/>	<input checked="" type="checkbox"/>	<input type="checkbox"/>	<input type="checkbox"/>	<input type="checkbox"/>	<input type="checkbox"/>	<input type="checkbox"/>	1TBN	8

Add

Delete

Move

Clear Used By

Inputs and Outputs

Inputs and Outputs

Enable Signal Required
 Check boxes

Port Number & Type

Port:

Inputs & Outputs

	DET No	Bit No	Type I or O	Name	Req'd	BP	Inv	U/D	Misc	DFM	DFM Group	Ext time	Phs	UTC	SDE	Used By				Term Block	Terminal No		
																Pri	HC	CC	IG	UD	LRT		
<input type="radio"/>	56	0	I	BPB	<input checked="" type="checkbox"/>	<input type="checkbox"/>	<input type="checkbox"/>	<input type="checkbox"/>	<input type="checkbox"/>	<input type="text" value="1"/>	<input type="text" value="2"/>	<input type="text" value="0.0"/>	<input checked="" type="checkbox"/>	<input type="checkbox"/>	<input type="checkbox"/>	<input checked="" type="checkbox"/>	<input type="checkbox"/>	<input type="checkbox"/>	<input type="checkbox"/>	<input type="checkbox"/>	<input type="checkbox"/>	1TBR	1
<input type="radio"/>	57	1	I	BPC	<input checked="" type="checkbox"/>	<input type="checkbox"/>	<input type="checkbox"/>	<input type="checkbox"/>	<input type="checkbox"/>	<input type="text" value="1"/>	<input type="text" value="2"/>	<input type="text" value="0.0"/>	<input checked="" type="checkbox"/>	<input type="checkbox"/>	<input type="checkbox"/>	<input checked="" type="checkbox"/>	<input type="checkbox"/>	<input type="checkbox"/>	<input type="checkbox"/>	<input type="checkbox"/>	<input type="checkbox"/>	1TBR	2
<input type="radio"/>	58	2	I	BPD	<input checked="" type="checkbox"/>	<input type="checkbox"/>	<input type="checkbox"/>	<input type="checkbox"/>	<input type="checkbox"/>	<input type="text" value="1"/>	<input type="text" value="2"/>	<input type="text" value="0.0"/>	<input checked="" type="checkbox"/>	<input type="checkbox"/>	<input type="checkbox"/>	<input checked="" type="checkbox"/>	<input type="checkbox"/>	<input type="checkbox"/>	<input type="checkbox"/>	<input type="checkbox"/>	<input type="checkbox"/>	1TBR	3
<input type="radio"/>	59	3	I		<input type="checkbox"/>	<input type="checkbox"/>	<input type="checkbox"/>	<input type="checkbox"/>	<input type="checkbox"/>				<input type="checkbox"/>	<input type="checkbox"/>	<input type="checkbox"/>	<input type="checkbox"/>	<input type="checkbox"/>	<input type="checkbox"/>	<input type="checkbox"/>	<input type="checkbox"/>	<input type="checkbox"/>		
<input type="radio"/>	60	4	I		<input type="checkbox"/>	<input type="checkbox"/>	<input type="checkbox"/>	<input type="checkbox"/>	<input type="checkbox"/>				<input type="checkbox"/>	<input type="checkbox"/>	<input type="checkbox"/>	<input type="checkbox"/>	<input type="checkbox"/>	<input type="checkbox"/>	<input type="checkbox"/>	<input type="checkbox"/>	<input type="checkbox"/>	1TBR	5
<input type="radio"/>	61	5	I	LF	<input checked="" type="checkbox"/>	<input type="checkbox"/>	<input checked="" type="checkbox"/>	<input type="checkbox"/>	<input type="checkbox"/>	<input type="text" value="N"/>	<input type="text"/>	<input type="text" value="0.0"/>	<input type="checkbox"/>	<input type="checkbox"/>	<input type="checkbox"/>	<input type="checkbox"/>	<input type="checkbox"/>	<input type="checkbox"/>	<input type="checkbox"/>	<input type="checkbox"/>	<input type="checkbox"/>	1TBR	6
<input type="radio"/>	62	6	I	RF1	<input checked="" type="checkbox"/>	<input type="checkbox"/>	<input checked="" type="checkbox"/>	<input type="checkbox"/>	<input type="checkbox"/>	<input type="text" value="N"/>	<input type="text"/>	<input type="text" value="0.0"/>	<input type="checkbox"/>	<input type="checkbox"/>	<input type="checkbox"/>	<input type="checkbox"/>	<input type="checkbox"/>	<input type="checkbox"/>	<input type="checkbox"/>	<input type="checkbox"/>	<input type="checkbox"/>	1TBR	7
<input type="radio"/>	63	7	I	RF2	<input checked="" type="checkbox"/>	<input type="checkbox"/>	<input checked="" type="checkbox"/>	<input type="checkbox"/>	<input type="checkbox"/>	<input type="text" value="N"/>	<input type="text"/>	<input type="text" value="0.0"/>	<input type="checkbox"/>	<input type="checkbox"/>	<input type="checkbox"/>	<input type="checkbox"/>	<input type="checkbox"/>	<input type="checkbox"/>	<input type="checkbox"/>	<input type="checkbox"/>	<input type="checkbox"/>	1TBR	8

-

Works Order : 5790/484/3
 EM Number : 66221
 Engineer : marco Gmys
 Intersection : B2068 Old Dover / St Lawrence Rd, Canterbury. 06/061

Aspect Drives

Aspect Drives

A-L M-X Y-F2

Phase Driver Card 1			
	Used For	Term Block	Term No
A - Red	Phase	1TBA	1
A - Amber	Phase	1TBA	2
A - Green	Phase	1TBA	3
B - Red	Phase	1TBA	4
B - Amber	Phase	1TBA	5
B - Green	Phase	1TBA	6
C - Red	Phase	1TBA	7
C - Amber	Phase	1TBA	8
C - Green	Phase	1TBA	9
D - Red	Phase	1TBA	10
D - Amber	Phase	1TBA	11
D - Green	Phase	1TBA	12

Phase Driver Card 1			
	Used For	Term Block	Term No
E - Red	Phase	1TBB	1
E - Amber	Phase	1TBB	2
E - Green	Phase	1TBB	3
F - Red	Phase	1TBB	4
F - Amber	Phase	1TBB	5
F - Green	Phase	1TBB	6
G - Red	Phase	1TBB	7
G - Amber	Phase	1TBB	8
G - Green	Phase	1TBB	9
H - Red			
H - Amber			
H - Green			

Phase Driver Card 2			
	Used For	Term Block	Term No
I - Red			
I - Amber			
I - Green			
J - Red			
J - Amber			
J - Green			
K - Red			
K - Amber			
K - Green			
L - Red			
L - Amber			
L - Green			

I/O - DFM Group Timings

I/O - DFM Group Timings

Input Group	State	SET A	SET B	SET C	SET D
Group 0	Active (Mins)	<input type="text" value="60"/>	<input type="text" value="60"/>	<input type="text" value="60"/>	<input type="text" value="60"/>
	InActive (Hrs)	<input type="text" value="18"/>	<input type="text" value="18"/>	<input type="text" value="18"/>	<input type="text" value="18"/>
Group 1	Active (Mins)	<input type="text" value="60"/>	<input type="text" value="60"/>	<input type="text" value="60"/>	<input type="text" value="60"/>
	InActive (Hrs)	<input type="text"/>	<input type="text"/>	<input type="text"/>	<input type="text"/>
Group 2	Active (Mins)	<input type="text" value="10"/>	<input type="text" value="10"/>	<input type="text" value="10"/>	<input type="text" value="10"/>
	InActive (Hrs)	<input type="text"/>	<input type="text"/>	<input type="text"/>	<input type="text"/>
Group 3	Active (Mins)	<input type="text" value="30"/>	<input type="text" value="30"/>	<input type="text" value="30"/>	<input type="text" value="30"/>
	InActive (Hrs)	<input type="text" value="18"/>	<input type="text" value="18"/>	<input type="text" value="18"/>	<input type="text" value="18"/>
Group 4	Active (Mins)	<input type="text" value="30"/>	<input type="text" value="30"/>	<input type="text" value="30"/>	<input type="text" value="30"/>
	InActive (Hrs)	<input type="text" value="18"/>	<input type="text" value="18"/>	<input type="text" value="18"/>	<input type="text" value="18"/>
Group 5	Active (Mins)	<input type="text" value="30"/>	<input type="text" value="30"/>	<input type="text" value="30"/>	<input type="text" value="30"/>
	InActive (Hrs)	<input type="text" value="18"/>	<input type="text" value="18"/>	<input type="text" value="18"/>	<input type="text" value="18"/>
Group 6	Active (Mins)	<input type="text" value="30"/>	<input type="text" value="30"/>	<input type="text" value="30"/>	<input type="text" value="30"/>
	InActive (Hrs)	<input type="text" value="18"/>	<input type="text" value="18"/>	<input type="text" value="18"/>	<input type="text" value="18"/>
Group 7	Active (Mins)	<input type="text" value="30"/>	<input type="text" value="30"/>	<input type="text" value="30"/>	<input type="text" value="30"/>
	InActive (Hrs)	<input type="text" value="18"/>	<input type="text" value="18"/>	<input type="text" value="18"/>	<input type="text" value="18"/>

Note - 255 or blank disables DFM monitoring of that state (active or inactive) during that timeset (A to D)

Handset Limiting Values

State	Min	Max
Active (Mins)	<input type="text" value="0"/>	<input type="text" value="255"/>
InActive (Hrs)	<input type="text" value="0"/>	<input type="text" value="255"/>

Index

- 1 General Junction Data
 - 1.1 Administration
 - 1.2 Phases, Stages and Streams
 - 1.3 Facilities/Modes Enabled and Mode Priority Levels
 - 1.4 Phases in Stages
 - 1.5 Stages in Streams
- 2 Phases
 - 2.1 Phase Type and Conditions
 - 2.2 Opposing and Conflicting Phases
 - 2.3 Timings
 - 2.3.1 Phase Minimums, Maximums, Extensions, Ped Leaving Periods
 - 2.3.2 Phase Intergreen Times
 - 2.3.3 Intergreen Handset Limits
 - 2.3.4 Phase Timing Handset Ranges
 - 2.4 VA Demand and Extend Definitions
 - 2.5 Phase Internal/Revertive Demands
- 3 Stage Movements
 - 3.1 Stages - Prohibited, Alternative, Ignored Moves
 - 3.2 Stage Internal Demands/Pedestrian Window Times
 - 3.3 Phase Delays (No configuration data to print)
- 4 Modes and Facilities - Detailed
 - 4.1 Fixed Time
 - 4.2 Cableless Linking
 - 4.2.1 CLF - Plan(s) (No configuration data to print)
 - 4.2.2 CLF - Demand Dependent Moves (No configuration data to print)
 - 4.3 UTC and MOVA
 - 4.3.1 UTC General Data
 - 4.3.2 UTC Control and Reply Data Format
 - 4.3.3 UTC Data Definitions
 - 4.3.3.1 UTC Phase Demand and Extend Definitions
 - 4.3.3.2 UTC Stage and Mode Data Definitions
 - 4.3.3.3 UTC Demand Dependent Forces (No configuration data to print)
 - 4.3.4 UTC and MOVA Detectors (No configuration data to print)
 - 4.4 Master Time Clock
 - 4.4.1 MTC - Time Switch Parameters
 - 4.4.2 MTC - Time Switch Parameters Array
 - 4.4.3 MTC - Day Type
 - 4.4.4 MTC - Timetable
 - 4.5 Priority and Emergency Vehicle
 - 4.5.1 Priority and Emergency Vehicle - General
 - 4.5.2 Priority - Delays, Unit Inhibits and Associations
 - 4.5.3 Priority Time Sets
 - 4.5.4 Priority - Allowed and Enforced Demands
 - 4.6 Hurry Call
 - 4.7 Manual
 - 4.7.1 Manual Panel
 - 4.7.2 Manual Mode - Optional Phases Appearance
 - 4.8 Extend All Red
 - 4.8.1 Extend All Red - General
 - 4.8.2 Extend All Red - Stage To Stage Moves
 - 4.8.3 Extend All Red - Independent Intergreens
- 5 Conditioning Data
 - 5.1 Special Conditioning
 - 5.2 Special Conditioning Timers
 - 5.3 Fault Log Flags (No configuration data to print)
- 6 Special Instructions
- 7 I/O
 - 7.1 Call Cancel
 - 7.2 Inputs and Outputs
 - 7.3 Aspect Drives
 - 7.4 I/O - DFM Group Timings

Works Order : 53624
 EM Number : 62260
 Engineer : Marco Gmys
 Intersection : B2068 Old Dover Road / Nackington Road - Canterbury. 06/060

Administration

General Specifications

Customer Name	<input type="text" value="Kent County Council"/>	Customer Order No.	<input type="text"/>
Intersection/ General Description	<input type="text" value="B2068 Old Dover Road / Nackington Road - Canterbury. 06/060"/>	Controller/ Serial Number	<input type="text"/>
Controller	<input checked="" type="radio"/> New <input type="radio"/> Modification	S.T.S. /EM Number	<input type="text" value="62260"/> Issue <input type="text" value="6"/>
Area Specifications/ Customer Drawings	<input type="text" value="2861/S/1C"/>	Equipment Installation by	<input type="text" value="Signal Company"/>
Specification Section	<input type="text"/>	Slot Cutting by	<input type="text" value="Signal Company"/>
Contract/Tender Ref:	<input type="text"/>	Civil Works by	<input type="text" value="Civils Contractor"/>
Quotation No.	<input type="text"/>	Customer's Engineer	<input type="text" value="P.Clark"/>
Works Order No.	<input type="text" value="53624"/>	Telephone Number	<input type="text" value="01622-666063"/>

Signal Company Use Only

Signal Engineer	<input type="text" value="Marco Gmys"/>	(IF PROM Label as >) PROM Number	<input type="text" value="16260"/>	PROM Variant	<input type="text" value="0"/>
		Configuration Check Value	<input type="text" value="B9 15 59 6D"/>		

Controller Options

Hardware	<input type="text" value="T800"/>	Firmware Type and Issue	<input type="text" value="PB800 ISS 18"/>	Other Options	<input type="text" value="KTD LO"/>
----------	-----------------------------------	-------------------------	---	---------------	-------------------------------------

ST950/ST900/ST750 Series Cabinet Options

Cabinet/Rack	Kit Type Options	<input type="radio"/>	<input type="radio"/>	<input type="radio"/>	<input type="radio"/>
Cabinet/Rack Variant	Cuckoo Options	<input type="checkbox"/>			

Mains Supply	<input type="text" value="240"/> Volts	<input type="text" value="50"/> Hz			
Peak Lamp Current	<input type="text" value="4"/> Amps	Dimming Voltage	<input type="text" value="160"/>	Answer Issue	<input type="text" value="2"/>
Average Lamp Power	<input type="text" value="600"/> Watts	Low Inrush Transformer	<input type="checkbox"/>	Edit Issue	<input type="text" value="25"/>
Total Average Power	<input type="text" value="800"/> Watts			Date Created	<input type="text" value="17/01/03"/>

Power feed fuse rating: requires 30 Amp minimum for controller, 15 Amp minimum for pelican/lightly loaded controller

Phases, Stages and Streams

Phases, Stages and Streams

Add/Delete/Insert Streams:

Streams	
<input checked="" type="radio"/>	Current Number of Streams <input type="text" value="1"/>

Phases	
<input type="radio"/>	Current Total Number of Phases <input type="text" value="10"/>
<input checked="" type="radio"/>	Number of Real Phases <input type="text" value="6"/>
<input type="radio"/>	Number of Dummy Phases <input type="text" value="4"/>

Stages	
<input type="radio"/>	Current Number of stages (inc. ALL-RED stages) <input type="text" value="5"/>

Switched Signs	
<input type="radio"/>	Number of Switched Signs <input type="text" value="0"/>

Action	
<input type="button" value="Add At"/>	<input type="button" value="Delete At"/>

Facilities/Modes Enabled and Mode Priority Levels

Facilities

UTC <input checked="" type="checkbox"/> Serial/Internal UTMC OTU <input type="checkbox"/> Free-standing OTU <input type="checkbox"/> Integral TC12 OTU <input checked="" type="checkbox"/> Serial MOVA	<input checked="" type="checkbox"/> Master Time Clock <input type="checkbox"/> Holiday Clock <input checked="" type="checkbox"/> FT To Current MAX <input type="checkbox"/> Linked Fixed Time	<input type="checkbox"/> Lamp Monitoring <input type="checkbox"/> RED Lamp Monitoring <input type="checkbox"/> Pelican/Puffin/Toucan <input type="checkbox"/> Standalone Manual	<input checked="" type="checkbox"/> Extend All Red <input type="checkbox"/> Speed Measurement <input type="checkbox"/> Ripple Change <input type="checkbox"/> London IMU	<input type="checkbox"/> Non-UK <input type="checkbox"/> Fail to Part Time <input type="checkbox"/> Fail To Hardware Flashing <input type="checkbox"/> <input type="checkbox"/> Download To Level 3
--	--	--	---	---

Starting Intergreen

Mode Priority

	1	2	3	4	5	6	7	8	9	10	11	12	13
<input type="checkbox"/> Part Time	<input type="radio"/>	<input type="radio"/>	<input type="radio"/>	<input type="radio"/>	<input type="radio"/>	<input type="radio"/>	<input type="radio"/>	<input type="radio"/>	<input type="radio"/>	<input type="radio"/>	<input type="radio"/>	<input type="radio"/>	<input type="radio"/>
<input type="checkbox"/> Emergency Vehicles	<input type="radio"/>	<input type="radio"/>	<input type="radio"/>	<input type="radio"/>	<input type="radio"/>	<input type="radio"/>	<input type="radio"/>	<input type="radio"/>	<input type="radio"/>	<input type="radio"/>	<input type="radio"/>	<input type="radio"/>	<input type="radio"/>
<input checked="" type="checkbox"/> Hurry Call	<input type="radio"/>	<input checked="" type="radio"/>	<input type="radio"/>	<input type="radio"/>	<input type="radio"/>	<input type="radio"/>	<input type="radio"/>	<input type="radio"/>	<input type="radio"/>	<input type="radio"/>	<input type="radio"/>	<input type="radio"/>	<input type="radio"/>
<input type="checkbox"/>	<input type="radio"/>	<input type="radio"/>	<input type="radio"/>	<input type="radio"/>	<input type="radio"/>	<input type="radio"/>	<input type="radio"/>	<input type="radio"/>	<input type="radio"/>	<input type="radio"/>	<input type="radio"/>	<input type="radio"/>	<input type="radio"/>
<input checked="" type="checkbox"/> Priority Vehicle	<input type="radio"/>	<input type="radio"/>	<input type="radio"/>	<input type="radio"/>	<input type="radio"/>	<input checked="" type="radio"/>	<input type="radio"/>	<input type="radio"/>	<input type="radio"/>	<input type="radio"/>	<input type="radio"/>	<input type="radio"/>	<input type="radio"/>
<input checked="" type="checkbox"/> Manual Control	<input checked="" type="radio"/>	<input type="radio"/>	<input type="radio"/>	<input type="radio"/>	<input type="radio"/>	<input type="radio"/>	<input type="radio"/>	<input type="radio"/>	<input type="radio"/>	<input type="radio"/>	<input type="radio"/>	<input type="radio"/>	<input type="radio"/>
<input type="checkbox"/> Manual Step On	<input type="radio"/>	<input type="radio"/>	<input type="radio"/>	<input type="radio"/>	<input type="radio"/>	<input type="radio"/>	<input type="radio"/>	<input type="radio"/>	<input type="radio"/>	<input type="radio"/>	<input type="radio"/>	<input type="radio"/>	<input type="radio"/>
<input checked="" type="checkbox"/> Selected FT or VA or CLF	<input type="radio"/>	<input type="radio"/>	<input checked="" type="radio"/>	<input type="radio"/>	<input type="radio"/>	<input type="radio"/>	<input type="radio"/>	<input type="radio"/>	<input type="radio"/>	<input type="radio"/>	<input type="radio"/>	<input type="radio"/>	<input type="radio"/>
<input checked="" type="checkbox"/> UTC	<input type="radio"/>	<input type="radio"/>	<input type="radio"/>	<input checked="" type="radio"/>	<input type="radio"/>	<input type="radio"/>	<input type="radio"/>	<input type="radio"/>	<input type="radio"/>	<input type="radio"/>	<input type="radio"/>	<input type="radio"/>	<input type="radio"/>
<input type="checkbox"/>	<input type="radio"/>	<input type="radio"/>	<input type="radio"/>	<input type="radio"/>	<input type="radio"/>	<input type="radio"/>	<input type="radio"/>	<input type="radio"/>	<input type="radio"/>	<input type="radio"/>	<input type="radio"/>	<input type="radio"/>	<input type="radio"/>
<input checked="" type="checkbox"/> CLF (Non-Base Time)	<input type="radio"/>	<input type="radio"/>	<input type="radio"/>	<input type="radio"/>	<input checked="" type="radio"/>	<input type="radio"/>	<input type="radio"/>	<input type="radio"/>	<input type="radio"/>	<input type="radio"/>	<input type="radio"/>	<input type="radio"/>	<input type="radio"/>
<input type="checkbox"/> CLF (Base Time)	<input type="radio"/>	<input type="radio"/>	<input type="radio"/>	<input type="radio"/>	<input type="radio"/>	<input type="radio"/>	<input type="radio"/>	<input type="radio"/>	<input type="radio"/>	<input type="radio"/>	<input type="radio"/>	<input type="radio"/>	<input type="radio"/>
<input checked="" type="checkbox"/> Vehicle Actuated	<input type="radio"/>	<input type="radio"/>	<input type="radio"/>	<input type="radio"/>	<input type="radio"/>	<input type="radio"/>	<input checked="" type="radio"/>	<input type="radio"/>	<input type="radio"/>	<input type="radio"/>	<input type="radio"/>	<input type="radio"/>	<input type="radio"/>
<input checked="" type="checkbox"/> Fixed Time	<input type="radio"/>	<input type="radio"/>	<input type="radio"/>	<input type="radio"/>	<input type="radio"/>	<input type="radio"/>	<input type="radio"/>	<input type="radio"/>	<input type="radio"/>	<input type="radio"/>	<input checked="" type="radio"/>	<input type="radio"/>	<input type="radio"/>

Configuration Complexity

Low
 Medium
 High
 Maximum

standard.8DF

Default PROM data file

Correspondence Monitoring to inc.

Reds
 Ambers
 Switched Signs
 Ignore Reds and Ambers during

Flash Rate (ms)

Off
 On

Works Order : 53624
EM Number : 62260
Engineer : Marco Gmys
Intersection : B2068 Old Dover Road / Nackington Road - Canterbury. 06/060

Phases in Stages

Phases

	A	B	C	D	E	F	G	H	I	J
0							■			
1	■	■								
2	■			■						
3					□	□		■	□	□
4			■							

Works Order : 53624
 EM Number : 62260
 Engineer : Marco Gmys
 Intersection : B2068 Old Dover Road / Nackington Road - Canterbury. 06/060

Stages in Streams

Stages in Streams

0 1 2 3 4 5 6 7

Phase or Stage to revert to in absence of demands/extensions

Startup Stage

Switch Off Stage

Standalone Pedestrian

Note: For a Stand-Alone Stream, the reversion must be to All Red stage or Traffic stage/phase to meet the relevant standard or specification.

Stages

	0	1	2	3	4	
In Stream	0	<input checked="" type="checkbox"/>	<input checked="" type="checkbox"/>	<input checked="" type="checkbox"/>	<input checked="" type="checkbox"/>	<input checked="" type="checkbox"/>

Works Order : 53624
 EM Number : 62260
 Engineer : Marco Gmys
 Intersection : B2068 Old Dover Road / Nackington Road - Canterbury. 06/060

Phase Type and Conditions

Phase Type and Conditions

Phases A to P

Phase	Title	Type	App. Type	Term. Type	Assoc. Phase
A	Old Dover Road N/W Ahead	0 - UK Traffic	0	0 - I	
B	Old Dover Road S/E	0 - UK Traffic	0	0 - I	
C	Nackington Road	0 - UK Traffic	0	0 - I	
D	Old Dover Road N/W Right Turn	2 - UK GreenArrow	0	2 - I	A
E	Peds across Old Dover Road S/E	1 - UK Far Side Pedestrian	2	0 - I	
F	Peds across Nackington Road	1 - UK Far Side Pedestrian	2	0 - I	
G	Dummy All Red	0 - UK Traffic	0	0 - I	
H	Dummy for Stage 3 Peds	1 - UK Far Side Pedestrian	0	0 - I	
I	Phase E dummy	1 - UK Far Side Pedestrian	1	0 - I	
J	Phase F dummy	1 - UK Far Side Pedestrian	1	0 - I	

1) App Types: 0 = Always Appears, 1 = Appears if dem'd prior to interstage, 2 = If dem'd, 3 = If dem'd before end of window time
 2) Term Types: 0 = Term's at end of stage, 1 = Term's when Assoc phase gains R.O.W, 2 = Term's when Assoc phase loses R.O.W.
 3) The H/W Fail Flash fields are for information only on all but ST900ELV Controllers. For other controllers, physical switches or links (etc.) select which aspects flash and these need to be set up manually.

Works Order : 53624
 EM Number : 62260
 Engineer : Marco Gmys
 Intersection : B2068 Old Dover Road / Nackington Road - Canterbury. 06/060

Opposing and Conflicting Phases

Select Stream(s) To Configure

All
 0

To Phase

		A	B	C	D	E	F	G	H	I	J
From Phase	A		o	Co	o	Co	Co	o	o	o	o
	B	o		Co	Co	Co	Co	o	o	o	o
	C	Co	Co		Co	Co	Co	o	o	o	o
	D	o	Co	Co		Co	Co	o	o	o	o
	E	Co	Co	Co	Co		o	o	o	o	o
	F	Co	Co	Co	Co	o		o	o	o	o
	G	o	o	o	o	o	o		o	o	o
	H	o	o	o	o	o	o	o		o	o
	I	o	o	o	o	o	o	o	o		o
	J	o	o	o	o	o	o	o	o	o	

Phase Minimums, Maximums, Extensions, Ped Leaving Periods

Phase Minimums, Maximums, Extensions, Ped Leaving Periods

Phases A to P

Phase	Min Green	Min Ped Clr	Extensions	Maximums								Pre-timed	
				A	B	C	D	E	F	G	H		
A	7	0	1.6	20	15	15	15	0	0	0	0	0	<input type="checkbox"/>
B	7	0	1.6	25	15	15	15	0	0	0	0	0	<input type="checkbox"/>
C	7	0	1.6	35	15	20	15	0	0	0	0	0	<input type="checkbox"/>
D	4	0	1.6	20	10	35	10	0	0	0	0	0	<input type="checkbox"/>
E	6	4	0.0	6	6	6	6	0	0	0	0	0	<input type="checkbox"/>
F	7	8	0.0	7	7	7	7	0	0	0	0	0	<input type="checkbox"/>
G	1	0	0.0	1	1	1	1	0	0	0	0	0	<input type="checkbox"/>
H	1	0	0.0	0	0	0	0	0	0	0	0	0	<input type="checkbox"/>
I	6	0	0.0	0	0	0	0	0	0	0	0	0	<input type="checkbox"/>
J	7	0	0.0	0	0	0	0	0	0	0	0	0	<input type="checkbox"/>
													<input type="checkbox"/>
													<input type="checkbox"/>
													<input type="checkbox"/>
													<input type="checkbox"/>
													<input type="checkbox"/>
													<input type="checkbox"/>

Note: For Standalone Streams see Help for use of Max Sets.

Works Order : 53624
 EM Number : 62260
 Engineer : Marco Gmys
 Intersection : B2068 Old Dover Road / Nackington Road - Canterbury. 06/060

Phase Intergreen Times

Select Stream(s) To Configure

All
 0

Note: On a Stand Alone Pelican/Toucan/Puffin Stream the Intergreens between Pedestrian and Traffic Phases are controlled by the timings (PBT, PIT, CMX, CDY, CRD and PAR), therefore 0 should be entered for the appropriate intergreen times in grid below.

To Phase

		A	B	C	D	E	F	G	H	I	J
From Phase	A			7		9	9	3	9	9	9
	B			7	5	5	8	3	5	5	8
	C	5	5		5	9	5	3	5	9	5
	D		6	7		9	9	3	9	9	9
	E	9	9	9	9			4			
	F	13	13	13	13			8			
	G	0	0	0	0	0	0		0		
	H	0	0	0	0			0			
	I										
	J										

Works Order : 53624
 EM Number : 62260
 Engineer : Marco Gmys
 Intersection : B2068 Old Dover Road / Nackington Road - Canterbury. 06/060

Intergreen Handset Limits

HIGH 199

Copy Intergreen Values

To Phase

From Phase

	A	B	C	D	E	F	G	H	I	J
A			7		9	9	3	3	9	9
B			7	5	5	8	3	3	5	8
C	5	5		5	9	5	3	3	9	5
D		6	7			9	3	3		9
E	9	9	9				4			
F	13	13	13	13			8			
G				3				3		
H										
I										
J										

Phase Timing Handset Ranges

Phase Timing Handset Ranges			
Initialise Min Green Limits			
Phase	Min. Green		Phase
	Min.	Max.	
A	<input type="text" value="3"/>	<input type="text" value="255"/>	Q
B	<input type="text" value="3"/>	<input type="text" value="255"/>	R
C	<input type="text" value="3"/>	<input type="text" value="255"/>	S
D	<input type="text" value="3"/>	<input type="text" value="255"/>	T
E	<input type="text" value="3"/>	<input type="text" value="255"/>	U
F	<input type="text" value="3"/>	<input type="text" value="255"/>	V
G	<input type="text" value="1"/>	<input type="text" value="255"/>	W
H	<input type="text" value="1"/>	<input type="text" value="255"/>	X
I	<input type="text" value="0"/>	<input type="text" value="255"/>	Y
J	<input type="text" value="0"/>	<input type="text" value="255"/>	Z
K			A2
L			B2
M			C2
N			D2
O			E2
P			F2

<table style="width: 100%;"> <tr> <th colspan="2" style="text-align: left; padding: 5px;">Min. Green</th> </tr> <tr> <td style="width: 50%;">Min.</td> <td style="width: 50%;"><input type="text" value="0"/></td> </tr> <tr> <td>Max.</td> <td><input type="text" value="255"/></td> </tr> </table>	Min. Green		Min.	<input type="text" value="0"/>	Max.	<input type="text" value="255"/>	
Min. Green							
Min.	<input type="text" value="0"/>						
Max.	<input type="text" value="255"/>						
<table style="width: 100%;"> <tr> <th colspan="2" style="text-align: left; padding: 5px;">Vehicle Extension</th> </tr> <tr> <td style="width: 50%;">Min.</td> <td style="width: 50%;"><input type="text" value="0.0"/></td> </tr> <tr> <td>Max.</td> <td><input type="text" value="10.0"/></td> </tr> </table>	Vehicle Extension		Min.	<input type="text" value="0.0"/>	Max.	<input type="text" value="10.0"/>	
Vehicle Extension							
Min.	<input type="text" value="0.0"/>						
Max.	<input type="text" value="10.0"/>						
<table style="width: 100%;"> <tr> <th colspan="2" style="text-align: left; padding: 5px;">Phase Delay</th> </tr> <tr> <td style="width: 50%;">Min.</td> <td style="width: 50%;"><input type="text" value="2"/></td> </tr> <tr> <td>Max.</td> <td><input type="text" value="10"/></td> </tr> </table>	Phase Delay		Min.	<input type="text" value="2"/>	Max.	<input type="text" value="10"/>	
Phase Delay							
Min.	<input type="text" value="2"/>						
Max.	<input type="text" value="10"/>						
<table style="width: 100%;"> <tr> <th colspan="2" style="text-align: left; padding: 5px;">Starting I/G</th> </tr> <tr> <td style="width: 50%;">Min.</td> <td style="width: 50%;"><input type="text" value="4"/></td> </tr> <tr> <td>Max.</td> <td><input type="text" value="14"/></td> </tr> </table>	Starting I/G		Min.	<input type="text" value="4"/>	Max.	<input type="text" value="14"/>	
Starting I/G							
Min.	<input type="text" value="4"/>						
Max.	<input type="text" value="14"/>						
<table style="width: 100%;"> <tr> <th colspan="2" style="text-align: left; padding: 5px;">Min Pedestrian Clearance (PBT)</th> </tr> <tr> <td style="width: 50%;">Min.</td> <td style="width: 50%;"><input type="text" value="0"/></td> </tr> <tr> <td>Max.</td> <td><input type="text" value="12"/></td> </tr> </table>	Min Pedestrian Clearance (PBT)		Min.	<input type="text" value="0"/>	Max.	<input type="text" value="12"/>	
Min Pedestrian Clearance (PBT)							
Min.	<input type="text" value="0"/>						
Max.	<input type="text" value="12"/>						
<table style="width: 100%;"> <tr> <th colspan="2" style="text-align: left; padding: 5px;">Traffic Phase Leaving</th> </tr> <tr> <td style="width: 50%;">Min.</td> <td style="width: 50%;"><input type="text" value="3.0"/></td> </tr> <tr> <td>Max.</td> <td><input type="text" value="3.0"/></td> </tr> </table>	Traffic Phase Leaving		Min.	<input type="text" value="3.0"/>	Max.	<input type="text" value="3.0"/>	
Traffic Phase Leaving							
Min.	<input type="text" value="3.0"/>						
Max.	<input type="text" value="3.0"/>						
<table style="width: 100%;"> <tr> <th colspan="2" style="text-align: left; padding: 5px;">Traffic Phase Red/Amber</th> </tr> <tr> <td style="width: 50%;">Min.</td> <td style="width: 50%;"><input type="text" value="2"/></td> </tr> <tr> <td>Max.</td> <td><input type="text" value="2"/></td> </tr> </table>	Traffic Phase Red/Amber		Min.	<input type="text" value="2"/>	Max.	<input type="text" value="2"/>	
Traffic Phase Red/Amber							
Min.	<input type="text" value="2"/>						
Max.	<input type="text" value="2"/>						

VA Demand and Extend Definitions

VA Demand and Extend Definitions

Demands

For Unlatched demands precede the name with a #.
 Conditioning MUST be used to specify unlatched demands.

Phase	AY	AZ		BPA
A				
B	BX	BY	BZ	BPB
C	CX	CY	CZ	BPC
D				BPD
E				
F				
G				
H				
I	PB3E	PB4E		
J	PB6F	PB7F		

Phases A to P

Extensions

AX	AY	AZ	
BX	BY	BZ	
CX	CY	CZ	
			DP

Works Order : 53624
 EM Number : 62260
 Engineer : Marco Gmys
 Intersection : B2068 Old Dover Road / Nackington Road - Canterbury. 06/060

Phase Internal/Revertive Demands

Phase Internal/Revertive Demands

Start-up Vehicle Responsive Demands

A	<input checked="" type="checkbox"/>	B	<input checked="" type="checkbox"/>	C	<input checked="" type="checkbox"/>	D	<input checked="" type="checkbox"/>	E	<input type="checkbox"/>	F	<input type="checkbox"/>	G	<input type="checkbox"/>	H	<input type="checkbox"/>	I	<input checked="" type="checkbox"/>	J	<input checked="" type="checkbox"/>	<input type="checkbox"/>	<input type="checkbox"/>	<input type="checkbox"/>	<input type="checkbox"/>	<input type="checkbox"/>	<input type="checkbox"/>
<input type="checkbox"/>	<input type="checkbox"/>	<input type="checkbox"/>	<input type="checkbox"/>	<input type="checkbox"/>	<input type="checkbox"/>	<input type="checkbox"/>	<input type="checkbox"/>	<input type="checkbox"/>	<input type="checkbox"/>	<input type="checkbox"/>	<input type="checkbox"/>	<input type="checkbox"/>	<input type="checkbox"/>	<input type="checkbox"/>	<input type="checkbox"/>	<input type="checkbox"/>	<input type="checkbox"/>	<input type="checkbox"/>	<input type="checkbox"/>	<input type="checkbox"/>	<input type="checkbox"/>	<input type="checkbox"/>	<input type="checkbox"/>		

Demands Inserted When Leaving Manual and Fixed Time Modes

A	<input checked="" type="checkbox"/>	B	<input checked="" type="checkbox"/>	C	<input checked="" type="checkbox"/>	D	<input checked="" type="checkbox"/>	E	<input type="checkbox"/>	F	<input type="checkbox"/>	G	<input type="checkbox"/>	H	<input type="checkbox"/>	I	<input checked="" type="checkbox"/>	J	<input checked="" type="checkbox"/>	<input type="checkbox"/>	<input type="checkbox"/>	<input type="checkbox"/>	<input type="checkbox"/>	<input type="checkbox"/>	<input type="checkbox"/>
<input type="checkbox"/>	<input type="checkbox"/>	<input type="checkbox"/>	<input type="checkbox"/>	<input type="checkbox"/>	<input type="checkbox"/>	<input type="checkbox"/>	<input type="checkbox"/>	<input type="checkbox"/>	<input type="checkbox"/>	<input type="checkbox"/>	<input type="checkbox"/>	<input type="checkbox"/>	<input type="checkbox"/>	<input type="checkbox"/>	<input type="checkbox"/>	<input type="checkbox"/>	<input type="checkbox"/>	<input type="checkbox"/>	<input type="checkbox"/>	<input type="checkbox"/>	<input type="checkbox"/>	<input type="checkbox"/>	<input type="checkbox"/>	<input type="checkbox"/>	<input type="checkbox"/>

Unlatched Demands that Start Max Timers

A	<input checked="" type="checkbox"/>	B	<input checked="" type="checkbox"/>	C	<input checked="" type="checkbox"/>	D	<input checked="" type="checkbox"/>	E	<input checked="" type="checkbox"/>	F	<input checked="" type="checkbox"/>	G	<input type="checkbox"/>	H	<input type="checkbox"/>	I	<input checked="" type="checkbox"/>	J	<input checked="" type="checkbox"/>	<input type="checkbox"/>	<input type="checkbox"/>	<input type="checkbox"/>	<input type="checkbox"/>	<input type="checkbox"/>	<input type="checkbox"/>
<input type="checkbox"/>	<input type="checkbox"/>	<input type="checkbox"/>	<input type="checkbox"/>	<input type="checkbox"/>	<input type="checkbox"/>	<input type="checkbox"/>	<input type="checkbox"/>	<input type="checkbox"/>	<input type="checkbox"/>	<input type="checkbox"/>	<input type="checkbox"/>	<input type="checkbox"/>	<input type="checkbox"/>	<input type="checkbox"/>	<input type="checkbox"/>	<input type="checkbox"/>	<input type="checkbox"/>	<input type="checkbox"/>	<input type="checkbox"/>	<input type="checkbox"/>	<input type="checkbox"/>	<input type="checkbox"/>	<input type="checkbox"/>	<input type="checkbox"/>	<input type="checkbox"/>

Revertive Phase Demands

A	B	C	D	E	F	G	H	I	J	K	L	M	N	O	P
<input type="text" value="A"/>	<input type="text" value="B"/>	<input type="text" value="C"/>	<input type="text" value="A"/>	<input type="text"/>	<input type="text"/>	<input type="text"/>	<input type="text"/>	<input type="text"/>	<input type="text"/>						
Q	R	S	T	U	V	W	X	Y	Z	A2	B2	C2	D2	E2	F2

Works Order : 53624
 EM Number : 62260
 Engineer : Marco Gmys
 Intersection : B2068 Old Dover Road / Nackington Road - Canterbury. 06/060

Stages - Prohibited, Alternative, Ignored Moves

Stages - Prohibited, Alternative, Ignored Moves

Sets

1

2

3

4

Modes	Restrictions Apply To:	No Restrictions
	<input checked="" type="radio"/>	<input type="radio"/>
	<input checked="" type="radio"/>	<input type="radio"/>
	<input checked="" type="radio"/>	<input type="radio"/>
	<input checked="" type="radio"/>	<input type="radio"/>
	<input checked="" type="radio"/>	<input type="radio"/>
	<input type="radio"/>	<input type="radio"/>

Modes	Restrictions Apply To:	No Restrictions
Manual	<input checked="" type="radio"/>	<input type="radio"/>
	<input checked="" type="radio"/>	<input type="radio"/>
	<input type="radio"/>	<input type="radio"/>
	<input type="radio"/>	<input type="radio"/>
	<input type="radio"/>	<input type="radio"/>

To Stage

From Stage	0	1	2	3	4
0					
1					
2		0			
3					
4					

Works Order : 53624
 EM Number : 62260
 Engineer : Marco Gmys
 Intersection : B2068 Old Dover Road / Nackington Road - Canterbury. 06/060

Stages - Prohibited, Alternative, Ignored Moves

Stages - Prohibited, Alternative, Ignored Moves

- Sets
- 1
 - 2
 - 3
 - 4

Modes	Restrictions Apply To:	No Restrictions
Urban Traffic Control	<input checked="" type="radio"/>	<input type="radio"/>
Cableless Linking	<input checked="" type="radio"/>	<input type="radio"/>
Vehicle Actuated	<input checked="" type="radio"/>	<input type="radio"/>
Hurry Call	<input checked="" type="radio"/>	<input type="radio"/>
Fixed Time	<input checked="" type="radio"/>	<input type="radio"/>
	<input type="radio"/>	<input type="radio"/>

Modes	Restrictions Apply To:	No Restrictions
	<input checked="" type="radio"/>	<input type="radio"/>
Priority	<input checked="" type="radio"/>	<input type="radio"/>
	<input type="radio"/>	<input type="radio"/>
	<input type="radio"/>	<input type="radio"/>
	<input type="radio"/>	<input type="radio"/>

To Stage

	0	1	2	3	4
0					
1	X				
2		0			
3	X				
4	X				

Stage Internal Demands/Pedestrian Window Times

Stage Internal Demands/Pedestrian Window Times

Start-up Vehicle Responsive Demands

0	<input type="checkbox"/>	1	<input type="checkbox"/>	2	<input type="checkbox"/>	3	<input type="checkbox"/>	4	<input type="checkbox"/>	<input type="checkbox"/>	<input type="checkbox"/>	<input type="checkbox"/>	<input type="checkbox"/>	<input type="checkbox"/>	<input type="checkbox"/>	<input type="checkbox"/>	<input type="checkbox"/>	<input type="checkbox"/>	<input type="checkbox"/>
	<input type="checkbox"/>		<input type="checkbox"/>		<input type="checkbox"/>		<input type="checkbox"/>		<input type="checkbox"/>		<input type="checkbox"/>		<input type="checkbox"/>		<input type="checkbox"/>		<input type="checkbox"/>		<input type="checkbox"/>

Demands Inserted When Leaving Manual and Fixed Time Modes

0	<input type="checkbox"/>	1	<input type="checkbox"/>	2	<input type="checkbox"/>	3	<input type="checkbox"/>	4	<input type="checkbox"/>	<input type="checkbox"/>	<input type="checkbox"/>	<input type="checkbox"/>	<input type="checkbox"/>	<input type="checkbox"/>	<input type="checkbox"/>	<input type="checkbox"/>	<input type="checkbox"/>	<input type="checkbox"/>	<input type="checkbox"/>
	<input type="checkbox"/>		<input type="checkbox"/>		<input type="checkbox"/>		<input type="checkbox"/>		<input type="checkbox"/>		<input type="checkbox"/>		<input type="checkbox"/>		<input type="checkbox"/>		<input type="checkbox"/>		<input type="checkbox"/>

Unlatched Demands that Start Maximum Timers

0	<input checked="" type="checkbox"/>	1	<input checked="" type="checkbox"/>	2	<input checked="" type="checkbox"/>	3	<input checked="" type="checkbox"/>	4	<input checked="" type="checkbox"/>	<input type="checkbox"/>	<input type="checkbox"/>	<input type="checkbox"/>	<input type="checkbox"/>	<input type="checkbox"/>	<input type="checkbox"/>	<input type="checkbox"/>	<input type="checkbox"/>	<input type="checkbox"/>	<input type="checkbox"/>
	<input type="checkbox"/>		<input type="checkbox"/>		<input type="checkbox"/>		<input type="checkbox"/>		<input type="checkbox"/>		<input type="checkbox"/>		<input type="checkbox"/>		<input type="checkbox"/>		<input type="checkbox"/>		<input type="checkbox"/>

Window Times

0	1	2	3	4	5	6	7	8	9	10	11	12	13	14	15
<input type="text" value="0"/>	<input type="text" value="0"/>	<input type="text" value="0"/>	<input type="text" value="0"/>	<input type="text" value="0"/>											
16	17	18	19	20	21	22	23	24	25	26	27	28	29	30	31

Exceptional Stages

<input type="checkbox"/>	<input type="checkbox"/>	<input type="checkbox"/>	<input type="checkbox"/>	<input type="checkbox"/>	<input type="checkbox"/>	<input type="checkbox"/>	<input type="checkbox"/>	<input type="checkbox"/>	<input type="checkbox"/>	<input type="checkbox"/>	<input type="checkbox"/>	<input type="checkbox"/>	<input type="checkbox"/>	<input type="checkbox"/>	<input type="checkbox"/>
<input type="checkbox"/>	<input type="checkbox"/>	<input type="checkbox"/>	<input type="checkbox"/>	<input type="checkbox"/>	<input type="checkbox"/>	<input type="checkbox"/>	<input type="checkbox"/>	<input type="checkbox"/>	<input type="checkbox"/>	<input type="checkbox"/>	<input type="checkbox"/>	<input type="checkbox"/>	<input type="checkbox"/>	<input type="checkbox"/>	<input type="checkbox"/>

Works Order : 53624
 EM Number : 62260
 Engineer : Marco Gmys
 Intersection : B2068 Old Dover Road / Nackington Road - Canterbury. 06/060

Fixed Time

Fixed Time

Stage Moves & Times (Not Fixed Time to Current Max)

Current Stage	0	1	2	3	4	5	6	7
Next Stage								
Time								
Current Stage	8	9	10	11	12	13	14	15
Next Stage								
Time								
Current Stage	16	17	18	19	20	21	22	23
Next Stage								
Time								
Current Stage	24	25	26	27	28	29	30	31
Next Stage								
Time								

Phases Demanded and Extended under Fixed Time to Current Max.

	A	B	C	D	E	F	G	H	I	J	K	L	M	N	O	P
Demand	<input checked="" type="checkbox"/>	<input checked="" type="checkbox"/>	<input checked="" type="checkbox"/>	<input checked="" type="checkbox"/>	<input type="checkbox"/>	<input type="checkbox"/>	<input type="checkbox"/>	<input type="checkbox"/>	<input checked="" type="checkbox"/>	<input checked="" type="checkbox"/>	<input type="checkbox"/>	<input type="checkbox"/>	<input type="checkbox"/>	<input type="checkbox"/>	<input type="checkbox"/>	<input type="checkbox"/>
Extend	<input checked="" type="checkbox"/>	<input checked="" type="checkbox"/>	<input checked="" type="checkbox"/>	<input checked="" type="checkbox"/>	<input type="checkbox"/>	<input type="checkbox"/>	<input type="checkbox"/>	<input type="checkbox"/>	<input type="checkbox"/>	<input type="checkbox"/>	<input type="checkbox"/>	<input type="checkbox"/>	<input type="checkbox"/>	<input type="checkbox"/>	<input type="checkbox"/>	<input type="checkbox"/>
	Q	R	S	T	U	V	W	X	Y	Z	A2	B2	C2	D2	E2	F2
Demand	<input type="checkbox"/>	<input type="checkbox"/>	<input type="checkbox"/>	<input type="checkbox"/>	<input type="checkbox"/>	<input type="checkbox"/>	<input type="checkbox"/>	<input type="checkbox"/>	<input type="checkbox"/>	<input type="checkbox"/>	<input type="checkbox"/>	<input type="checkbox"/>	<input type="checkbox"/>	<input type="checkbox"/>	<input type="checkbox"/>	<input type="checkbox"/>
Extend	<input type="checkbox"/>	<input type="checkbox"/>	<input type="checkbox"/>	<input type="checkbox"/>	<input type="checkbox"/>	<input type="checkbox"/>	<input type="checkbox"/>	<input type="checkbox"/>	<input type="checkbox"/>	<input type="checkbox"/>	<input type="checkbox"/>	<input type="checkbox"/>	<input type="checkbox"/>	<input type="checkbox"/>	<input type="checkbox"/>	<input type="checkbox"/>

Works Order : 53624
EM Number : 62260
Engineer : Marco Gmys
Intersection : B2068 Old Dover Road / Nackington Road - Canterbury. 06/060

CLF - Demand Dependent Moves

Clear Grid Data

Notes:
If no data is entered for a stage then a demand for any phases in that stage will be considered. The data specified on this screen will also change the screen CLF - Demands to Consider with Demand Dependent Stage Moves.

Phases

	A	B	C	D	E	F	G	H	I	J
0										
1										
2				■						
3					■	■			■	■
4			■							

UTC General Data

UTC General Data

Type of UTC

106

316

Integral OTU Address

Number of Control Words

Number of Reply Words

Controller to respond to TC bit.

Introduction of UTC to be disabled by Priority and LR

Non UTC RTC synchronisation input name

RTC Synchronisation Times

Clock Synchronise Time (UTC TS input)

Day

Time

Clock Confirm Time (UTC RT output)

Day

Time

Works Order : 53624
 EM Number : 62260
 Engineer : Marco Gmys
 Intersection : B2068 Old Dover Road / Nackington Road - Canterbury. 06/060

UTC Control and Reply Data Format

UTC Control and Reply Data Format

	Bit 1	Bit 2	Bit 3	Bit 4	Bit 5	Bit 6	Bit 7	Bit 8
Control Words								
Word 1	F1	#F2	#F3	#F4	D2	D3	D4	DX1
Word 2	TS							
Word 3								
Word 4								
Reply Words								
Word 1	G1	G2	G3	G4	SD2	SD3	SD4	DF
Word 2	CCC	SP1	RR	LF1	LF2	BD1	BD2	BD3
Word 3	BD4	CC						
Word 4								
Word 5								
Word 6								
Word 7								
Word 8								
Word 9								
Word 10								
Word 11								
Word 12								
Word 13								
Word 14								

UTC Phase Demand and Extend Definitions

UTC Demand and Extend Definitions

Demands

Phase For Unlatched demands, precede the name with a #.
 Conditioning MUST be used to specify unlatched demands.

A	DX1			
B	DX1			
C	DX1	D4		
D	DX1	D2		
E				
F				
G				
H				
I	DX1	D3		
J	DX1	D3		

Phases A to P

Extensions

DX1			
DX1			
DX1	D4		
DX1	D2		

UTC Stage and Mode Data Definitions

UTC Stage and Mode Data Definitions

Stage	Force Bit	Green Confirm Bit	Demand Confirm Bit	Stage	Force Bit	Green Confirm Bit	Demand Confirm Bit
0				16			
1	F1	G1		17			
2	#F2	G2	SD2	18			
3	#F3		SD3	19			
4	#F4	G4	SD4	20			
5				21			
6				22			
7				23			
8				24			
9				25			
10				26			
11				27			
12				28			
13				29			
14				30			
15				31			

Mode Data Definitions

Manual Mode Operative:
 G1/G2 RR

Manual Mode Selected:
 G1/G2 RR

No Lamp Power, or Lamps Off due to RLM or Part Time:

G1/G2

Detector Fault:

 DF

Normal NOT selected on the Manual Panel:

G1/G2 RR

RR Button Selected:

G1/G2 RR

If UTC Reply Confirms are required for a Controller Fault (CF) OR for separate MC and RR replies, Conditioning must be used.

Works Order : 53624
EM Number : 62260
Engineer : Marco Gmys
Intersection : B2068 Old Dover Road / Nackington Road - Canterbury. 06/060

UTC Demand Dependent Forces

Clear Grid Data

Notes:

If no data is entered for a stage then a demand for any phases in that stage will be considered. The data specified on this screen will also change the screen CLF - Demands to Consider with Demand Dependent Stage Moves.

Phases

	A	B	C	D	E	F	G	H	I	J
0										
1										
2				■						
3					■	■			■	■
4			■							

MTC - Time Switch Parameters

MTC - Time Switch Parameters

	Type	Event		Type	Event
0	Alternate Max	MAXSETB	16	No Action	
1	Alternate Max	MAXSETC	17	No Action	
2	Alternate Max	MAXSETD	18	No Action	
3	Alternate DFM	ALTDFMB	19	No Action	
4	Alternate DFM	ALTDFMC	20	No Action	
5	Alternate DFM	ALTDFMD	21	No Action	
6	No Action		22	No Action	
7	No Action		23	No Action	
8	No Action		24	No Action	
9	No Action		25	No Action	
10	No Action		26	No Action	
11	No Action		27	No Action	
12	No Action		28	No Action	
13	No Action		29	No Action	
14	No Action		30	No Action	
15	No Action		31	No Action	

Works Order : 53624
 EM Number : 62260
 Engineer : Marco Gmys
 Intersection : B2068 Old Dover Road / Nackington Road - Canterbury. 06/060

MTC - Time Switch Parameters Array

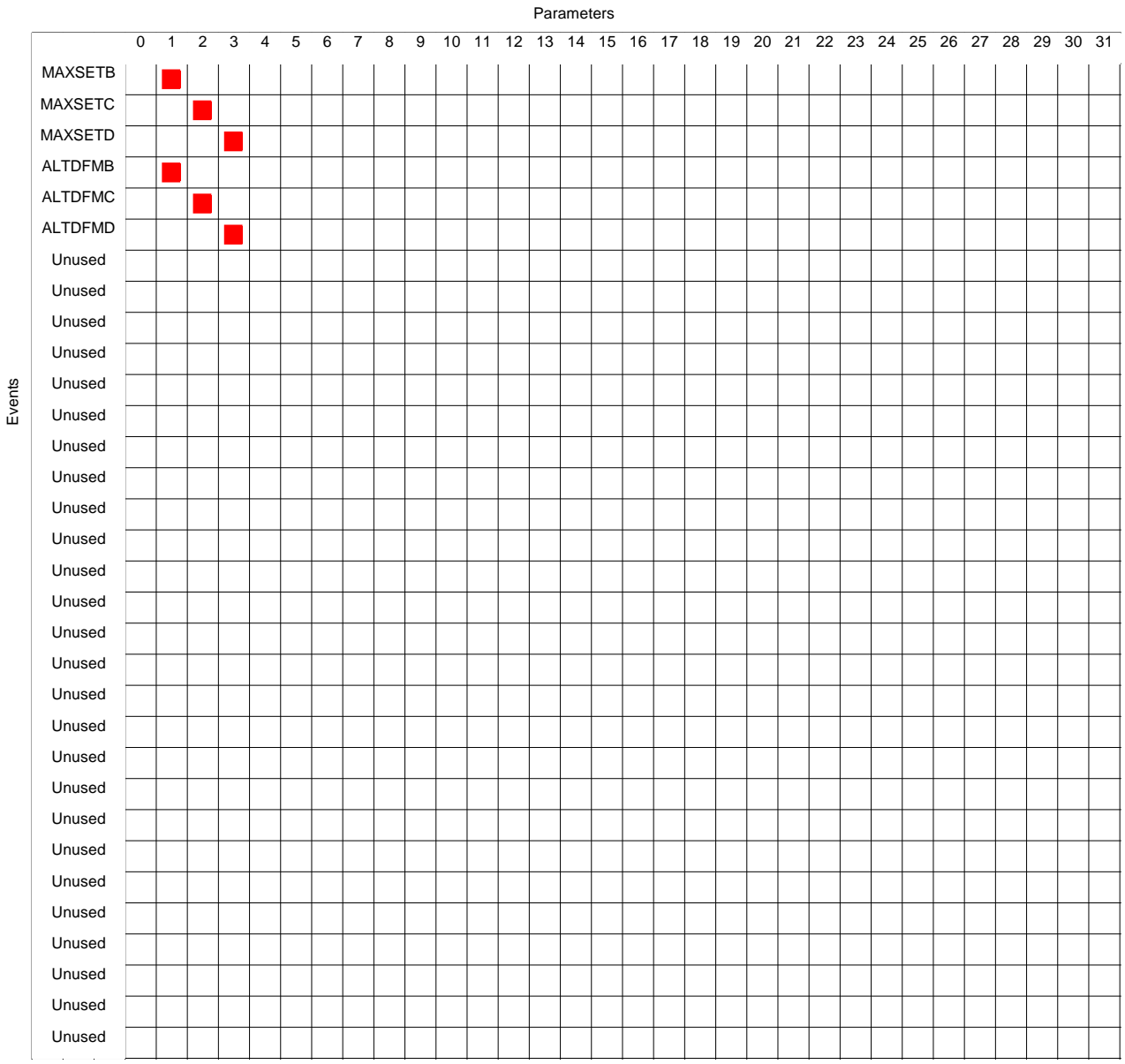

Works Order : 53624
EM Number : 62260
Engineer : Marco Gmys
Intersection : B2068 Old Dover Road / Nackington Road - Canterbury. 06/060

MTC - Day Type

MTC - Day Type							
No.	Mon	Tue	Wed	Thu	Fri	Sat	Sun
0	<input type="checkbox"/>	<input type="checkbox"/>	<input type="checkbox"/>	<input type="checkbox"/>	<input type="checkbox"/>	<input checked="" type="checkbox"/>	<input type="checkbox"/>
1	<input type="checkbox"/>	<input type="checkbox"/>	<input type="checkbox"/>	<input type="checkbox"/>	<input type="checkbox"/>	<input type="checkbox"/>	<input checked="" type="checkbox"/>
2	<input checked="" type="checkbox"/>	<input type="checkbox"/>	<input type="checkbox"/>	<input type="checkbox"/>	<input type="checkbox"/>	<input type="checkbox"/>	<input type="checkbox"/>
3	<input type="checkbox"/>	<input checked="" type="checkbox"/>	<input type="checkbox"/>	<input type="checkbox"/>	<input type="checkbox"/>	<input type="checkbox"/>	<input type="checkbox"/>
4	<input type="checkbox"/>	<input type="checkbox"/>	<input checked="" type="checkbox"/>	<input type="checkbox"/>	<input type="checkbox"/>	<input type="checkbox"/>	<input type="checkbox"/>
5	<input type="checkbox"/>	<input type="checkbox"/>	<input type="checkbox"/>	<input checked="" type="checkbox"/>	<input type="checkbox"/>	<input type="checkbox"/>	<input type="checkbox"/>
6	<input type="checkbox"/>	<input type="checkbox"/>	<input type="checkbox"/>	<input type="checkbox"/>	<input checked="" type="checkbox"/>	<input type="checkbox"/>	<input type="checkbox"/>
7	<input checked="" type="checkbox"/>	<input checked="" type="checkbox"/>	<input checked="" type="checkbox"/>	<input checked="" type="checkbox"/>	<input checked="" type="checkbox"/>	<input checked="" type="checkbox"/>	<input checked="" type="checkbox"/>
8	<input checked="" type="checkbox"/>	<input checked="" type="checkbox"/>	<input checked="" type="checkbox"/>	<input checked="" type="checkbox"/>	<input checked="" type="checkbox"/>	<input checked="" type="checkbox"/>	<input type="checkbox"/>
9	<input checked="" type="checkbox"/>	<input checked="" type="checkbox"/>	<input checked="" type="checkbox"/>	<input checked="" type="checkbox"/>	<input checked="" type="checkbox"/>	<input type="checkbox"/>	<input type="checkbox"/>
10	<input type="checkbox"/>	<input type="checkbox"/>	<input type="checkbox"/>	<input type="checkbox"/>	<input type="checkbox"/>	<input type="checkbox"/>	<input type="checkbox"/>
11	<input type="checkbox"/>	<input type="checkbox"/>	<input type="checkbox"/>	<input type="checkbox"/>	<input type="checkbox"/>	<input type="checkbox"/>	<input type="checkbox"/>
12	<input type="checkbox"/>	<input type="checkbox"/>	<input type="checkbox"/>	<input type="checkbox"/>	<input type="checkbox"/>	<input type="checkbox"/>	<input type="checkbox"/>
13	<input type="checkbox"/>	<input type="checkbox"/>	<input type="checkbox"/>	<input type="checkbox"/>	<input type="checkbox"/>	<input type="checkbox"/>	<input type="checkbox"/>
14	<input type="checkbox"/>	<input type="checkbox"/>	<input type="checkbox"/>	<input type="checkbox"/>	<input type="checkbox"/>	<input type="checkbox"/>	<input type="checkbox"/>
15	<input type="checkbox"/>	<input type="checkbox"/>	<input type="checkbox"/>	<input type="checkbox"/>	<input type="checkbox"/>	<input type="checkbox"/>	<input type="checkbox"/>

MTC - Timetable

MTC - Timetable

View Timetable Settings

0 - 15
 16 - 31
 32 - 47
 48 - 63

No.	Day Type	Time	Description	Function Code	Plan/Parameter
0	9	07:30:00	MAXSET A	2	0
1	9	09:30:00	MAXSET B	2	1
2	9	15:00:00	MAXSET C	2	2
3	9	18:30:00	MAXSET D	2	3
4	0	07:30:00	MAXSET B	2	1
5	0	19:00:00	MAXSET D	2	3
6	1	08:30:00	MAXSET B	2	1
7	1	18:30:00	MAXSET D	2	3
8	0		PLAN 1	1	1
9	0		PLAN 2	1	2
10	0		PLAN 3	1	3
11	0		PLAN 4	1	4
12	0		ISOLATE	0	0
13	0		PLAN 2	1	2
14	0		PLAN 4	1	4
15	0		ISOLATE	0	0

Function Codes:

0 = Isolate From CLF

1 = Introduce a CLF Plan

2 = Introduce a Parameter
(Combination of event switches)

3 = Selects an Individual event
switch to be set

4 = Selects an Individual event
switch to be cleared.

Priority and Emergency Vehicle - General

Priority and Emergency Vehicle - General

	Input Name	Type Priority / Emergency		Phase	DFM Time (x10)	Gap Time	DFM Self Reset	Demands Sets				Revertive Demands Sets				Revertive Demands to Start Inhibit Timer Sets										
		P	E					0	1	2	3	0	1	2	3	0	1	2	3							
Unit 0	<input type="text" value="BPA"/>	<input checked="" type="radio"/>	<input type="radio"/>	<input type="text" value="A"/>	<input type="text" value="60"/>	<input type="text" value="4"/>	<input type="text" value="0"/>	<input checked="" type="checkbox"/>	<input checked="" type="checkbox"/>	<input checked="" type="checkbox"/>	<input checked="" type="checkbox"/>	<input type="checkbox"/>	<input type="checkbox"/>	<input type="checkbox"/>	<input type="checkbox"/>	<input type="checkbox"/>	<input type="checkbox"/>	<input type="checkbox"/>	<input type="checkbox"/>	<input type="checkbox"/>	<input type="checkbox"/>	<input type="checkbox"/>	<input type="checkbox"/>	<input type="checkbox"/>	<input type="checkbox"/>	<input type="checkbox"/>
Unit 1	<input type="text" value="BPB"/>	<input checked="" type="radio"/>	<input type="radio"/>	<input type="text" value="B"/>	<input type="text" value="60"/>	<input type="text" value="4"/>	<input type="text" value="0"/>	<input checked="" type="checkbox"/>	<input checked="" type="checkbox"/>	<input checked="" type="checkbox"/>	<input checked="" type="checkbox"/>	<input type="checkbox"/>	<input type="checkbox"/>	<input type="checkbox"/>	<input type="checkbox"/>	<input type="checkbox"/>	<input type="checkbox"/>	<input type="checkbox"/>	<input type="checkbox"/>	<input type="checkbox"/>	<input type="checkbox"/>	<input type="checkbox"/>	<input type="checkbox"/>	<input type="checkbox"/>	<input type="checkbox"/>	<input type="checkbox"/>
Unit 2	<input type="text" value="BPC"/>	<input checked="" type="radio"/>	<input type="radio"/>	<input type="text" value="C"/>	<input type="text" value="60"/>	<input type="text" value="4"/>	<input type="text" value="0"/>	<input checked="" type="checkbox"/>	<input checked="" type="checkbox"/>	<input checked="" type="checkbox"/>	<input checked="" type="checkbox"/>	<input type="checkbox"/>	<input type="checkbox"/>	<input type="checkbox"/>	<input type="checkbox"/>	<input type="checkbox"/>	<input type="checkbox"/>	<input type="checkbox"/>	<input type="checkbox"/>	<input type="checkbox"/>	<input type="checkbox"/>	<input type="checkbox"/>	<input type="checkbox"/>	<input type="checkbox"/>	<input type="checkbox"/>	<input type="checkbox"/>
Unit 3	<input type="text" value="BPD"/>	<input checked="" type="radio"/>	<input type="radio"/>	<input type="text" value="D"/>	<input type="text" value="60"/>	<input type="text" value="4"/>	<input type="text" value="0"/>	<input checked="" type="checkbox"/>	<input checked="" type="checkbox"/>	<input checked="" type="checkbox"/>	<input checked="" type="checkbox"/>	<input type="checkbox"/>	<input type="checkbox"/>	<input type="checkbox"/>	<input type="checkbox"/>	<input type="checkbox"/>	<input type="checkbox"/>	<input type="checkbox"/>	<input type="checkbox"/>	<input type="checkbox"/>	<input type="checkbox"/>	<input type="checkbox"/>	<input type="checkbox"/>	<input type="checkbox"/>	<input type="checkbox"/>	<input type="checkbox"/>
Unit 4	<input type="text"/>	<input checked="" type="radio"/>	<input type="radio"/>	<input type="text"/>	<input type="text" value="30"/>	<input type="text" value="4"/>	<input type="text" value="0"/>	<input checked="" type="checkbox"/>	<input checked="" type="checkbox"/>	<input checked="" type="checkbox"/>	<input checked="" type="checkbox"/>	<input checked="" type="checkbox"/>	<input checked="" type="checkbox"/>	<input checked="" type="checkbox"/>	<input checked="" type="checkbox"/>	<input checked="" type="checkbox"/>	<input checked="" type="checkbox"/>	<input type="checkbox"/>	<input type="checkbox"/>	<input type="checkbox"/>	<input type="checkbox"/>	<input type="checkbox"/>	<input type="checkbox"/>	<input type="checkbox"/>	<input type="checkbox"/>	<input type="checkbox"/>
Unit 5	<input type="text"/>	<input checked="" type="radio"/>	<input type="radio"/>	<input type="text"/>	<input type="text" value="30"/>	<input type="text" value="4"/>	<input type="text" value="0"/>	<input checked="" type="checkbox"/>	<input checked="" type="checkbox"/>	<input checked="" type="checkbox"/>	<input checked="" type="checkbox"/>	<input checked="" type="checkbox"/>	<input checked="" type="checkbox"/>	<input checked="" type="checkbox"/>	<input checked="" type="checkbox"/>	<input checked="" type="checkbox"/>	<input checked="" type="checkbox"/>	<input type="checkbox"/>	<input type="checkbox"/>	<input type="checkbox"/>	<input type="checkbox"/>	<input type="checkbox"/>	<input type="checkbox"/>	<input type="checkbox"/>	<input type="checkbox"/>	<input type="checkbox"/>
Unit 6	<input type="text"/>	<input checked="" type="radio"/>	<input type="radio"/>	<input type="text"/>	<input type="text" value="30"/>	<input type="text" value="4"/>	<input type="text" value="0"/>	<input checked="" type="checkbox"/>	<input checked="" type="checkbox"/>	<input checked="" type="checkbox"/>	<input checked="" type="checkbox"/>	<input checked="" type="checkbox"/>	<input checked="" type="checkbox"/>	<input checked="" type="checkbox"/>	<input checked="" type="checkbox"/>	<input checked="" type="checkbox"/>	<input checked="" type="checkbox"/>	<input type="checkbox"/>	<input type="checkbox"/>	<input type="checkbox"/>	<input type="checkbox"/>	<input type="checkbox"/>	<input type="checkbox"/>	<input type="checkbox"/>	<input type="checkbox"/>	<input type="checkbox"/>
Unit 7	<input type="text"/>	<input checked="" type="radio"/>	<input type="radio"/>	<input type="text"/>	<input type="text" value="30"/>	<input type="text" value="4"/>	<input type="text" value="0"/>	<input checked="" type="checkbox"/>	<input checked="" type="checkbox"/>	<input checked="" type="checkbox"/>	<input checked="" type="checkbox"/>	<input checked="" type="checkbox"/>	<input checked="" type="checkbox"/>	<input checked="" type="checkbox"/>	<input checked="" type="checkbox"/>	<input checked="" type="checkbox"/>	<input checked="" type="checkbox"/>	<input type="checkbox"/>	<input type="checkbox"/>	<input type="checkbox"/>	<input type="checkbox"/>	<input type="checkbox"/>	<input type="checkbox"/>	<input type="checkbox"/>	<input type="checkbox"/>	<input type="checkbox"/>

Inputs From Conditioning

Note:
 Bus Priority Unit values will not be used unless a valid Input Name is specified
 If Bus Unit is to generate a VA demand, then input name must also be specified on VA demands screen

Note:
 Valid values for DFM Self Reset: 1 or 0 for PB800, 0-255 for PB801 and later

Priority - Delays, Unit Inhibits and Associations

Priority - Delays, Unit Inhibits and Associations																			
	Delay Time		Priority Units Inhibited					Associated Priority Units											
	First	Second	0	1	2	3	4	5	6	7	0	1	2	3	4	5	6	7	
Unit 0			<input checked="" type="checkbox"/>	<input type="checkbox"/>	<input type="checkbox"/>	<input type="checkbox"/>	<input type="checkbox"/>	<input type="checkbox"/>	<input type="checkbox"/>	<input type="checkbox"/>	<input type="checkbox"/>	<input type="checkbox"/>	<input type="checkbox"/>	<input type="checkbox"/>	<input type="checkbox"/>	<input type="checkbox"/>	<input type="checkbox"/>	<input type="checkbox"/>	<input type="checkbox"/>
Unit 1			<input type="checkbox"/>	<input checked="" type="checkbox"/>	<input type="checkbox"/>	<input type="checkbox"/>	<input type="checkbox"/>	<input type="checkbox"/>	<input type="checkbox"/>	<input type="checkbox"/>	<input type="checkbox"/>	<input type="checkbox"/>	<input type="checkbox"/>	<input type="checkbox"/>	<input type="checkbox"/>	<input type="checkbox"/>	<input type="checkbox"/>	<input type="checkbox"/>	<input type="checkbox"/>
Unit 2			<input type="checkbox"/>	<input type="checkbox"/>	<input checked="" type="checkbox"/>	<input type="checkbox"/>	<input type="checkbox"/>	<input type="checkbox"/>	<input type="checkbox"/>	<input type="checkbox"/>	<input type="checkbox"/>	<input type="checkbox"/>	<input type="checkbox"/>	<input type="checkbox"/>	<input type="checkbox"/>	<input type="checkbox"/>	<input type="checkbox"/>	<input type="checkbox"/>	<input type="checkbox"/>
Unit 3			<input type="checkbox"/>	<input type="checkbox"/>	<input type="checkbox"/>	<input checked="" type="checkbox"/>	<input type="checkbox"/>	<input type="checkbox"/>	<input type="checkbox"/>	<input type="checkbox"/>	<input type="checkbox"/>	<input type="checkbox"/>	<input type="checkbox"/>	<input type="checkbox"/>	<input type="checkbox"/>	<input type="checkbox"/>	<input type="checkbox"/>	<input type="checkbox"/>	<input type="checkbox"/>
Unit 4			<input type="checkbox"/>	<input type="checkbox"/>	<input type="checkbox"/>	<input type="checkbox"/>	<input type="checkbox"/>	<input type="checkbox"/>	<input type="checkbox"/>	<input type="checkbox"/>	<input type="checkbox"/>	<input type="checkbox"/>	<input type="checkbox"/>	<input type="checkbox"/>	<input type="checkbox"/>	<input type="checkbox"/>	<input type="checkbox"/>	<input type="checkbox"/>	<input type="checkbox"/>
Unit 5			<input type="checkbox"/>	<input type="checkbox"/>	<input type="checkbox"/>	<input type="checkbox"/>	<input type="checkbox"/>	<input type="checkbox"/>	<input type="checkbox"/>	<input type="checkbox"/>	<input type="checkbox"/>	<input type="checkbox"/>	<input type="checkbox"/>	<input type="checkbox"/>	<input type="checkbox"/>	<input type="checkbox"/>	<input type="checkbox"/>	<input type="checkbox"/>	<input type="checkbox"/>
Unit 6			<input type="checkbox"/>	<input type="checkbox"/>	<input type="checkbox"/>	<input type="checkbox"/>	<input type="checkbox"/>	<input type="checkbox"/>	<input type="checkbox"/>	<input type="checkbox"/>	<input type="checkbox"/>	<input type="checkbox"/>	<input type="checkbox"/>	<input type="checkbox"/>	<input type="checkbox"/>	<input type="checkbox"/>	<input type="checkbox"/>	<input type="checkbox"/>	<input type="checkbox"/>
Unit 7			<input type="checkbox"/>	<input type="checkbox"/>	<input type="checkbox"/>	<input type="checkbox"/>	<input type="checkbox"/>	<input type="checkbox"/>	<input type="checkbox"/>	<input type="checkbox"/>	<input type="checkbox"/>	<input type="checkbox"/>	<input type="checkbox"/>	<input type="checkbox"/>	<input type="checkbox"/>	<input type="checkbox"/>	<input type="checkbox"/>	<input type="checkbox"/>	<input type="checkbox"/>
Handset Delay Limits																			
First Delay Handset Range	Min	Max	Second Delay Handset Range				Min	Max											

Works Order : 53624
 EM Number : 62260
 Engineer : Marco Gmys
 Intersection : B2068 Old Dover Road / Nackington Road - Canterbury. 06/060

Priority Time Sets

Priority Time Sets

Sets

0 2
 1 3

Copy Set

Priority Unit	0	1	2	3	4	5	6	7
Maximum time (secs)	30	30	30	30	15	15	15	15
Extension time (secs)	10.0	10.0	10.0	10.0	10.0	10.0	10.0	10.0
Inhibit Time (secs)	120	120	120	120	50	50	50	50

Compensation Times

	A	B	C	D	E	F	G	H	I	J
0										
1										
2										
3										
4										
5										
6										
7										

Priority Units

Works Order : 53624
 EM Number : 62260
 Engineer : Marco Gmys
 Intersection : B2068 Old Dover Road / Nackington Road - Canterbury. 06/060

Priority Time Sets

Priority Time Sets

Sets

0 2

1 3

Copy Set

Priority Unit	0	1	2	3	4	5	6	7
Maximum time (secs)	30	30	30	30	15	15	15	15
Extension time (secs)	10.0	10.0	10.0	10.0	10.0	10.0	10.0	10.0
Inhibit Time (secs)	120	120	120	120	50	50	50	50

Compensation Times

	A	B	C	D	E	F	G	H	I	J
0										
1										
2										
3										
4										
5										
6										
7										

Priority Units

Priority Time Sets

Priority Time Sets

Sets

0 2

1 3

Copy Set

Priority Unit	0	1	2	3	4	5	6	7
Maximum time (secs)	30	30	30	30	15	15	15	15
Extension time (secs)	10.0	10.0	10.0	10.0	10.0	10.0	10.0	10.0
Inhibit Time (secs)	120	120	120	120	50	50	50	50

Compensation Times

	A	B	C	D	E	F	G	H	I	J
0										
1										
2										
3										
4										
5										
6										
7										

Priority Units

Works Order : 53624
 EM Number : 62260
 Engineer : Marco Gmys
 Intersection : B2068 Old Dover Road / Nackington Road - Canterbury. 06/060

Priority Time Sets

Priority Time Sets

Sets

0 2

1 3

Copy Set

Priority Unit	0	1	2	3	4	5	6	7
Maximum time (secs)	30	30	30	30	15	15	15	15
Extension time (secs)	10.0	10.0	10.0	10.0	10.0	10.0	10.0	10.0
Inhibit Time (secs)	120	120	120	120	50	50	50	50

Compensation Times

	A	B	C	D	E	F	G	H	I	J
0										
1										
2										
3										
4										
5										
6										
7										

Priority Units

Works Order : 53624
EM Number : 62260
Engineer : Marco Gmys
Intersection : B2068 Old Dover Road / Nackington Road - Canterbury. 06/060

Priority - Allowed and Enforced Demands

Phase

	A	B	C	D	E	F	G	H	I	J
0										
1										
2										
3										
4										
5										
6										
7										

Works Order : 53624
 EM Number : 62260
 Engineer : Marco Gmys
 Intersection : B2068 Old Dover Road / Nackington Road - Canterbury. 06/060

Hurry Call

Hurry Call

Hurry Call	Stage Called	Call Input Name	Cancel Input Name	Confirm Output Name	Delay Time	Hold Time	Prevent Time
0	<input type="text" value="2"/>	<input type="text" value="*SCRT10"/>	<input type="text" value="CANCLHC0"/>	<input type="text"/>	<input type="text" value="0"/>	<input type="text" value="30"/>	<input type="text" value="0"/>
1	<input type="text" value="1"/>	<input type="text" value="*SCRT12"/>	<input type="text"/>	<input type="text"/>	<input type="text" value="25"/>	<input type="text" value="7"/>	<input type="text" value="0"/>
2	<input type="text"/>	<input type="text"/>	<input type="text"/>	<input type="text"/>	<input type="text" value="0"/>	<input type="text" value="0"/>	<input type="text" value="0"/>
3	<input type="text"/>	<input type="text"/>	<input type="text"/>	<input type="text"/>	<input type="text" value="0"/>	<input type="text" value="0"/>	<input type="text" value="0"/>
4	<input type="text"/>	<input type="text"/>	<input type="text"/>	<input type="text"/>	<input type="text" value="0"/>	<input type="text" value="0"/>	<input type="text" value="0"/>
5	<input type="text"/>	<input type="text"/>	<input type="text"/>	<input type="text"/>	<input type="text" value="0"/>	<input type="text" value="0"/>	<input type="text" value="0"/>
6	<input type="text"/>	<input type="text"/>	<input type="text"/>	<input type="text"/>	<input type="text" value="0"/>	<input type="text" value="0"/>	<input type="text" value="0"/>
7	<input type="text"/>	<input type="text"/>	<input type="text"/>	<input type="text"/>	<input type="text" value="0"/>	<input type="text" value="0"/>	<input type="text" value="0"/>

Hurry Call Limit Values

	Min.	Max.
Call Delay	<input type="text" value="0"/>	<input type="text" value="255"/>
Call Hold	<input type="text" value="0"/>	<input type="text" value="255"/>
Call Prevent	<input type="text" value="0"/>	<input type="text" value="255"/>

Works Order : 53624
 EM Number : 62260
 Engineer : Marco Gmys
 Intersection : B2068 Old Dover Road / Nackington Road - Canterbury. 06/060

Manual Panel

Manual Panel

Stage Buttons and LEDs

Button No.	Title	Called Stage for Stream							
		0	1	2	3	4	5	6	7
0	All Red Stage	<input type="text" value="0"/>							
1	Stage 1	<input type="text" value="1"/>							
2	Stage 2	<input type="text" value="2"/>							
3	Stage 3	<input type="text" value="3"/>							
4	Stage 4	<input type="text" value="4"/>							
5	<input type="text"/>	<input type="text"/>							
6	<input type="text"/>	<input type="text"/>							
7	<input type="text"/>	<input type="text"/>							

General LEDs

	AUX 1	AUX 2	AUX 3	AUX 4 (Hurry Call)	AUX 5 (Higher Priority)
Conditioned	<input checked="" type="checkbox"/>	<input checked="" type="checkbox"/>	<input checked="" type="checkbox"/>	<input type="checkbox"/>	<input checked="" type="checkbox"/>

Manual Mode Enable

Always
 When Handset Plugged in (Note 1)
 When 'MND' Command Entered

NOTE:
For this to operate Special Conditioning is required.

General Buttons

	None	SW1	SW2	SW3
Momentary		<input type="checkbox"/>	<input type="checkbox"/>	<input type="checkbox"/>
Dim Override	<input type="radio"/>	<input checked="" type="radio"/>	<input type="radio"/>	<input type="radio"/>
RR	<input checked="" type="radio"/>	<input type="radio"/>	<input type="radio"/>	<input type="radio"/>

Manual Signals On

Immediate Signals On
 As Start-Up

Mode Select Switches Disabled

VA Fixed Time CLF

Works Order : 53624
 EM Number : 62260
 Engineer : Marco Gmys
 Intersection : B2068 Old Dover Road / Nackington Road - Canterbury. 06/060

Manual Mode - Optional Phases Appearance

Manual Mode - Optional Phases Appearance																
	A	B	C	D	E	F	G	H	I	J	K	L	M	N	O	P
Never Appears	<input type="radio"/>	<input type="radio"/>	<input type="radio"/>	<input type="radio"/>	<input type="radio"/>	<input type="radio"/>	<input type="radio"/>	<input type="radio"/>	<input type="radio"/>	<input type="radio"/>	<input type="radio"/>	<input type="radio"/>	<input type="radio"/>	<input type="radio"/>	<input type="radio"/>	<input type="radio"/>
Demand Dependant	<input type="radio"/>	<input type="radio"/>	<input type="radio"/>	<input type="radio"/>	<input checked="" type="radio"/>	<input checked="" type="radio"/>	<input type="radio"/>	<input type="radio"/>	<input type="radio"/>	<input type="radio"/>	<input type="radio"/>	<input type="radio"/>	<input type="radio"/>	<input type="radio"/>	<input type="radio"/>	<input type="radio"/>
Always Appears	<input checked="" type="radio"/>	<input checked="" type="radio"/>	<input checked="" type="radio"/>	<input checked="" type="radio"/>	<input type="radio"/>	<input type="radio"/>	<input checked="" type="radio"/>	<input checked="" type="radio"/>	<input checked="" type="radio"/>	<input checked="" type="radio"/>	<input type="radio"/>	<input type="radio"/>	<input type="radio"/>	<input type="radio"/>	<input type="radio"/>	<input type="radio"/>
	Q	R	S	T	U	V	W	X	Y	Z	A2	B2	C2	D2	E2	F2
Never Appears	<input type="radio"/>	<input type="radio"/>	<input type="radio"/>	<input type="radio"/>	<input type="radio"/>	<input type="radio"/>	<input type="radio"/>	<input type="radio"/>	<input type="radio"/>	<input type="radio"/>	<input type="radio"/>	<input type="radio"/>	<input type="radio"/>	<input type="radio"/>	<input type="radio"/>	<input type="radio"/>
Demand Dependant	<input type="radio"/>	<input type="radio"/>	<input type="radio"/>	<input type="radio"/>	<input type="radio"/>	<input type="radio"/>	<input type="radio"/>	<input type="radio"/>	<input type="radio"/>	<input type="radio"/>	<input type="radio"/>	<input type="radio"/>	<input type="radio"/>	<input type="radio"/>	<input type="radio"/>	<input type="radio"/>
Always Appears	<input type="radio"/>	<input type="radio"/>	<input type="radio"/>	<input type="radio"/>	<input type="radio"/>	<input type="radio"/>	<input type="radio"/>	<input type="radio"/>	<input type="radio"/>	<input type="radio"/>	<input type="radio"/>	<input type="radio"/>	<input type="radio"/>	<input type="radio"/>	<input type="radio"/>	<input type="radio"/>

Extend All Red - General

Extend All Red - General

Auto Extend to Max

- Part Time
- Emergency Vehicle
- Hurry Call
- LRT
- Priority
- Manual
- Manual Step On
- UTC
- MOVA
- CLF
- VA*
- Fixed Time

All Red Timings

Stream	0	1	2	3	4	5	6	7
Extension Time	<input style="width: 100px;" type="text" value="0.6"/>							
Max Time	<input style="width: 100px;" type="text" value="8"/>							

* Selecting Extend to Max on VA mode will also cause Extend to Max on CLF, UTC and Priority modes.

Detectors Associated with All Red Extension Units

Unit	Associated Detectors						
1	AR1	MVD3	MVD6				
2							
3							
4							
5							
6							
7							

The association between detectors and extension units must be performed in special conditioning.

Works Order : 53624
EM Number : 62260
Engineer : Marco Gmys
Intersection : B2068 Old Dover Road / Nackington Road - Canterbury. 06/060

Extend All Red - Stage To Stage Moves

		To Stage				
		0	1	2	3	4
From Stage	0	■				
	1		■		1	
	2			■	1	
	3				■	
	4					■

Works Order : 53624
EM Number : 62260
Engineer : Marco Gmys
Intersection : B2068 Old Dover Road / Nackington Road - Canterbury. 06/060

Extend All Red - Independent Intergreens

Phase Not Affected by Hold

	A	B	C	D	E	F	G	H	I	J
A	■									
B		■								
C			■							
D				■						
E					■					
F						■				
G							■			
H								■		
I									■	
J										■

Works Order : 53624
EM Number : 62260
Engineer : Marco Gmys
Intersection : B2068 Old Dover Road / Nackington Road - Canterbury. 06/060

Special Conditioning

```
; USE OF SCRATCH BITS
; -----
; SCRT0
; SCRT1
; SCRT2
; SCRT3
; SCRT4
; SCRT5
; SCRT6
; SCRT7
; SCRT8
; SCRT9
; SCRT10 = REQUEST HURRY CALL 0
; SCRT11 = CONFIRMATION THAT HURRY CALL 0 HAS RUN, SO AS TO ALLOW HURRY CALL 1
; SCRT12 = REQUEST HURRY CALL 1
; SCRT13 = NOT STAGE3 AND DEMANDS FOR PHASES I J (E _F)
; SCRT14 = NOT STAGE3 AND DEMANDS FOR PHASE J (F)
; SCRT15 = NOT STAGE3 AND DEMANDS FOR PHASE I (E)

; HURRY CALL CONDITIONING
; =====

; REQUEST HURRY CALL 0
; -----
CCTO2.CCTO3.NOT(PHASEE).NOT(PHASEF).NOT(CNDTMA1)=SCRT10 ; HURRY CALL 0 IS REQUESTED, BY SCRT10, IF
; BOTH HURRY CALL CALL CANCEL INPUTS ARE TRUE
; AND PHASE E IS NOT GREEN
; AND PHASE F IS NOT GREEN
; AND HURRY CALL PREVENT CONDITIONING TIMER 1
; IS NOT RUNNING

; HURRY CALL 0 PREVENT PERIOD
; -----
IFT HRYSTT1 EQL<1> THN ; IF HURRY CALL 0 IS TIMING REQUEST OR FORCING HURRY MODE
RUN<0> ; REPEATEDLY START CONDITIONING TIMER 0
END

IFT (HRYSTT1 EQL<2>).CNDTER0 THN ; IF HURRY CALL 0 IS TIMING HOLD PERIOD AND CONDITIONING TIMER 0
RUN<1> ; HAS JUST TERMINATED THEN START CONDITIONING TIMER 1
END

; CANCEL HURRY CALL 0
; -----
IFT HRYSTT1 EQL<2> THN ; IF HURRY CALL 0 IS TIMING HOLD PERIOD THEN
IFT (NOT(HC1).NOT(HC2))+LCPHI+LCPHJ) THN ; HURRY CALL 0 IS CANCELLED IF EITHER
TRUE=CANCLHC0 ; LOOPS HC1 AND HC2 ARE BOTH UNOCCUPIED
END ; OR
END ; PHASE I OR PHASE J (E OF F) ARE DEMANDED

; REQUEST HURRY CALL 1
; -----
; HURRY CALL 1 MAY BE ENABLED/ DISABLED BY HANDSET USING THE
; CONDITIONING FACILTIY ENABLE COMMAND "CFE".
; CONTROLLER CFE0 DEFAULT VALUE IS NORMALLY "0" (DISABLED)
; WHEREAS THE REQUIRED DEFAULT STATE FOR HURRY CALL 1 IS ENABLED.
; THEREFORE IN CONDITIONING THE RESULTANT STATE OF CFE0 HAS BEEN INVERTED
```

Works Order : 53624
EM Number : 62260
Engineer : Marco Gmys
Intersection : B2068 Old Dover Road / Nackington Road - Canterbury. 06/060

Special Conditioning

```
; TO ALLOW THE DEFAULT VALUE OF "0" TO MEAN ENABLED.
;
; TO DISABLE HURRY CALL 1 SET CFE0 TO "1"
; TO ENABLE HURRY CALL 1 SET CFE0 TO "0"
;
IFT NOT(CFE0 EQL<1>) THN      ; IF HURRY CALL 1 CONDITIONING IS ENABLED THEN
IFT HRYSTT1 EQL<2> THN      ; IF HURRY CALL 0 IS TIMING HOLD PERIOD THEN
RUN<2>                      ; REPEATEDLY START CONDITIONING TIMER 2
END

IFT CNDTER2 THN             ; IF CONDITIONING TIMER 2 HAS JUST TERMINATED THEN
TRUE=SCRT11                ; SET SCRATCH BIT SCRT11 TRUE
END

IFT NOT(PREVC).PHASEC.SCRT11 THN ; IF PHASE C HAS JUST GONE TO GREEN AND
TRUE=SCRT12                ; SCRATCH BIT SCRT11 IS TRUE THEN
ELS                        ; SET SCRATCH BIT SCRT12 TRUE
FALSE=SCRT12              ; OTHERWISE SET SCRATCH BIT SCRT12 TO FALSE
END

IFT PHASEB THN             ; IF PHASE B IS AT GREEN THEN
FALSE=SCRT11              ; RESET SCRATCH BIT SCRT11 TO FALSE
END

END

; STAGE 1 REVERSION WITH UNSATISFIED PED DEMAND
;~~~~~
STAGE3.(LCPHI+LCPHJ).(NOT(LCPHC+UCPHC+LCPHD+UCPHD))=+LCPHB ;ALLOW REVERT TO STAGE 1 IF A PED PHASE DEMAND AT INTER
;STAGE TO STAGE 3.

; UTC G3 REPLY BIT
;~~~~~

IFT (NOT(NXTSTG0 EQL<3>)).LCPHI.NOT(LCPHJ) THN
  TRUE=SCRT15
ELS
  IFT (NOT(NXTSTG0 EQL<3>)).LCPHJ.NOT(LCPHI) THN
    TRUE=SCRT14
ELS
  IFT (NOT(NXTSTG0 EQL<3>)).LCPHI.LCPHJ THN
    TRUE=SCRT13
  END
END

IFT FROME+FROMF THN
  FALSE=SCRT15
  FALSE=SCRT14
  FALSE=SCRT13
END

NOT(NXTSTG0 EQL<3>)((SCRT15.(NOT(SCRT14)).PHASEE)+(SCRT14.(NOT(SCRT15)).PHASEF)+(SCRT13.PHASEE.PHASEF))=G3

MAUXSW1=MIL22                ;AUX 1 LED LIT WHEN SWITCH 1 OPERATED ( dimming override )
(MODE0 EQL<6>)=MIL23         ;AUX 2 LED LIT WHEN UTC ACTIVE
(MODE0 EQL<3>)=MIL05         ;AUX 3 LED LIT WHEN RUNNING CLF
```

Works Order : 53624
EM Number : 62260
Engineer : Marco Gmys
Intersection : B2068 Old Dover Road / Nackington Road - Canterbury. 06/060

Special Conditioning

```
(MODE0 EQL<13>)=MIL17 ;BUS PRIORITY LIGHTS HIGHER PRIORITY LED
CCTO0=+LCPHB ;CALL CANCEL UNIT 0 INSERTS A LATCHED DEMAND FOR PHASE B
LMPON.LPSPRD.SWLMP.S.Not(FLF17).NOT(STAGE1)=G1 ;LAMPS OFF AND STAGE CONFIRMS FOR UTC G1 _G2 BITS
LMPON.LPSPRD.SWLMP.S.Not(FLF17).NOT(STAGE2)=G2
NOT((MODE0 EQL<1>+MODE0 EQL<2>+MODE0 EQL<4>))=RR ;RR BIT REPLIES MANUAL,F.T AND VA MODES
NOT(MODE0 EQL<13>)=SP1 ;SP1 BIT REPLIES WHEN IN PRIORITY MODE
NOT(BPA)=BD1 ;BD1 REPLIES WHEN INPUT BPA IS ACTIVE
NOT(BPB)=BD2 ;BD2 REPLIES WHEN INPUT BPB IS ACTIVE
NOT(BPC)=BD3 ;BD3 REPLIES WHEN INPUT BPC IS ACTIVE
NOT(BPD)=BD4 ;BD4 REPLIES WHEN INPUT BPD IS ACTIVE
NOT(LMPANY0)=LF1 ;ANY LAMP FAIL REPLIES UTC LF1 BIT.
NOT(LMP2RED0)=LF2 ;SECOND RED LAMP FAIL REPLIES UTC LF2 BIT.
AR1+AR1_EXT+MVD3+MVD6+SSFIX=IGEO1 ;AR1 MVD3 _MVD6 ACTIVE
AR1'+MVD3'+MVD6'+SSFIX=IGEC1 ;AR1 MVD3 _MVD6 CLEARED
; RTC SYNC CONFIRM SIGNAL
; ~~~~~
; CONFIRM SIGNALS AFTER SYNC TIME AS FOLLOWS -
;SUNDAY----- FOR 3 SECONDS
;MONDAY----- FOR 5 SECONDS
;TUESDAY----- FOR 7 SECONDS
;WEDNESDAY-- FOR 9 SECONDS
;THURSDAY--- FOR 11 SECONDS
;FRIDAY----- FOR 13 SECONDS
;SATURDAY--- FOR 15 SECONDS
IFT 1SCRT254.NOT CC THN
TRUE=1SCRT255
END
1SCRT254.NOT(1SCRT255)=CCC
NOT(MODE0 EQL<8>)=+1SCRT254
NOT((RTCDYS EQL<1>).(RTCSEC GRT<2>))=.1SCRT255 ; RESET FLAG - SUNDAY
NOT((RTCDYS EQL<2>).(RTCSEC GRT<4>))=.1SCRT255 ; RESET FLAG - MONDAY
NOT((RTCDYS EQL<3>).(RTCSEC GRT<6>))=.1SCRT255 ; RESET FLAG - TUESDAY
NOT((RTCDYS EQL<4>).(RTCSEC GRT<8>))=.1SCRT255 ; RESET FLAG - WEDNESDAY
NOT((RTCDYS EQL<5>).(RTCSEC GRT<10>))=.1SCRT255 ; RESET FLAG - THURSDAY
NOT((RTCDYS EQL<6>).(RTCSEC GRT<12>))=.1SCRT255 ; RESET FLAG - FRIDAY
NOT((RTCDYS EQL<0>).(RTCSEC GRT<14>))=.1SCRT255 ; RESET FLAG - SATURDAY
```

Works Order : 53624
EM Number : 62260
Engineer : Marco Gmys
Intersection : B2068 Old Dover Road / Nackington Road - Canterbury. 06/060

Special Conditioning

```
; EXTERNAL LAMP MONITORING FACILITY
; -----
RF2:.PHASEE=1AUXCMDE4           ; DOUBLE RED FAIL SENDS ALL PEDESTRIAN PHASES TO RED
*.PHASEF=1AUXCMD4F4

RF2:+LCPHI=+1WTCTRL           ; WAIT INDICATORS LIT IF DEMAND EXISTS
*.LCPHJ=+1WTCTRL             ; FOR ASSOCIATED DUMMY PHASE(S) OR IF RF2 PRESENT

FALSE::=.LCPHE               ; REMOVES ALL PEDESTRIAN PHASE DEMANDS UNTIL
*.UCPHE                       ; FOLLOWING BLOCK INSERTS THEM
*.LCPHF
*.UCPHF

PHASEI.((NOT CNDTMA3)+(NOT RF1)).(NOT RF2)=+UCPHE ; DEMAND REAL PEDESTRIAN PHASE WHEN DUMMY REACHES
; GREEN IF RF1 ABSENT OR AFTER DELAY TIMER IF RF1 PRESENT
; DO NOT DEMAND AT ALL IF RF2 PRESENT

PHASEJ.((NOT CNDTMA4)+(NOT RF1)).(NOT RF2)=+UCPHF ; DEMAND REAL PEDESTRIAN PHASE WHEN DUMMY REACHES
; GREEN IF RF1 ABSENT OR AFTER DELAY TIMER IF RF1 PRESENT
; DO NOT DEMAND AT ALL IF RF2 PRESENT

RF2:+LCPHE=PRVPHE            ; PREVENT PEDESTRIAN PHASES FROM APPEARING IF RF2
*.LCPHF=PRVPHF              ; PRESENT OR IF A LATCHED DEMAND EXISTS

IFT (NOT PHASEI) THN         ; RESET RLMU DELAY TIMERS IF ASSOCIATED DUMMY PHASES
RUN <3>                       ; ARE NOT AT GREEN
END

IFT (NOT PHASEJ) THN
RUN <4>
END

(NOT RF2)::=.PRSLMPAE=+UCPHI ; WAIT LAMP LIT ON REAL PHASE DEMANDS DUMMY PHASE
*.PRSLMPAF=+UCPHJ           ; PROVIDING RF2 NOT PRESENT
*.PRSLMPAE=+LCPHI
*.PRSLMPAF=+LCPHJ

(NOT RF2)::=.LCPHI          ; REMOVE ALL DUMMY PHASE DEMANDS IF RF2 PRESENT
*.UCPHI
*.LCPHJ
*.UCPHJ

INC 1SCRTCH30                ; IF THE LMU SIGNALS A RED FAIL
(RF1+RF2).1SCRT241=CABLMP    ; FLASH THE DFM LAMP
(NOT(MODE0 EQL <8>)):.LF=1PEDFLF0 ; ANY LAMP FAIL SETS FLF23=1
*.RF1=1PEDFLF1              ; SINGLE RED FAIL SETS FLF23=2
*.RF2=1PEDFLF2              ; DOUBLE RED FAIL SETS FLF23=4
; N.B. MULTIPLE FAILURES COULD GIVE OTHER VALUES

NOT(LF).NOT(RF1)=LF1         ; ANY LAMP FAIL REPLIES LF1
NOT(RF2)=LF2                 ; 2ND RED FAIL REPLIES LF2
```

Works Order : 53624
EM Number : 62260
Engineer : Marco Gmys
Intersection : B2068 Old Dover Road / Nackington Road - Canterbury. 06/060

Special Conditioning

```
; ADDITIONAL DETECTOR DEMANDS / EXTENSIONS  
; ~~~~~  
DX+DY+DZ=+LCPHA ;DX, DY OR DZ INSERTS A LATCHED DEMAND FOR PHASE A  
(DX_EXT+DY_EXT+DZ_EXT).(STAGE1):=+EXOA ;DX, DY OR DZ EXTENDS PHASE A DURING STAGE 1  
 ;*=+EXCA  
DX_EXT+DY_EXT+DZ_EXT:=+EXOD ;DX, DY OR DZ EXTENDS PHASE D DURING STAGE 2  
 ;*=+EXCD
```

Special Conditioning Timers

Special Conditioning Timers

Timers

0-31

No	Value	Min	Max	200ms	Description	No	Value	Min	Max	200ms	Description
0	1	0	255	<input type="checkbox"/>	Timer used to start Timer 1	16		0	255	<input type="checkbox"/>	
1	50	0	255	<input type="checkbox"/>	Hurry Call 0 prevent timer	17		0	255	<input type="checkbox"/>	
2	1	0	255	<input type="checkbox"/>	Timer used to request Hurry Call 1	18		0	255	<input type="checkbox"/>	
3	2	0	255	<input type="checkbox"/>	Phase E RLM delay timer	19		0	255	<input type="checkbox"/>	
4	2	0	255	<input type="checkbox"/>	Phase F RLM delay timer	20		0	255	<input type="checkbox"/>	
5		0	255	<input type="checkbox"/>		21		0	255	<input type="checkbox"/>	
6		0	255	<input type="checkbox"/>		22		0	255	<input type="checkbox"/>	
7		0	255	<input type="checkbox"/>		23		0	255	<input type="checkbox"/>	
8		0	255	<input type="checkbox"/>		24		0	255	<input type="checkbox"/>	
9		0	255	<input type="checkbox"/>		25		0	255	<input type="checkbox"/>	
10		0	255	<input type="checkbox"/>		26		0	255	<input type="checkbox"/>	
11		0	255	<input type="checkbox"/>		27		0	255	<input type="checkbox"/>	
12		0	255	<input type="checkbox"/>		28		0	255	<input type="checkbox"/>	
13		0	255	<input type="checkbox"/>		29		0	255	<input type="checkbox"/>	
14		0	255	<input type="checkbox"/>		30		0	255	<input type="checkbox"/>	
15		0	255	<input type="checkbox"/>		31		0	255	<input type="checkbox"/>	

Works Order : 53624
EM Number : 62260
Engineer : Marco Gmys
Intersection : B2068 Old Dover Road / Nackington Road - Canterbury. 06/060

Special Instructions

Board	Position	Sket	Port	Type I or O	Line	Cable	Block
CPU	A	X3I	0	I	00 - 07	101	1TBG
CPU	A	X3I	1	I	08 - 15		1TBH
CPU	A	X3O	11	O	88 - 91	105	1TBX
IO1	B	B	2	I	16 - 23	103	1TBJ
IO1	B	E	4	O	32 - 39		1TBK
IO1	B	C	3	I	24 - 31	103	1TBL
IO1	B	D	5	O	40 - 47		1TBM
IO2	C	B	6	I	48 - 55	103	1TBN
IO2	C	E	8	O	64 - 71		1TBP
IO2	C	C	7	I	56 - 63	103	1TBR
IO2	C	D	9	O	72 - 79		1TBS

The socket X3 on the CPU pcb is the double stacked one
X3I = Inner (nearest the board)
X3O = Outer

Works Order : 53624
 EM Number : 62260
 Engineer : Marco Gmys
 Intersection : B2068 Old Dover Road / Nackington Road - Canterbury. 06/060

Special Instructions

ST800 CONTROLLER ITEMS LIST SHEET 1 (*I*L*)

ITEM	DRAWING NUMBER	DESCRIPTION	QTY	TOT	REMARKS
1					
2	667/1/27000/001	Cabinet 8 Phase wired 16 Phase		1	
3	667/1/27000/002	Cabinet 24 Phase wired 32 Phase			
4	667/1/27001/001	Rack 8 Phase wired 16 Phase			
5	667/1/27001/002	Rack 24 Phase wired 32 Phase			
6					
7					
8					
9					
10					
11					
12					
13					
14					
15					
16					
17					
18					
19					
20					
21					
22					
23					
24	667/1/27002/000	Lamp Switch Kit 8 Phase			
25	667/1/27003/000	I/O Kit		2	
26	667/1/27005/000	SDE Facility Kit			
27	667/1/27004/000	Integral OTU Kit			
28					
29					
30					
31					
32					
33					
34					
35					
36					
37					
38					
39	667/1/16260/000	Configuration Eprom (Issue 1. 0)		1	
40					

Note 1:
 Please refer to special instruction pages for additional information on items marked with an '*'.

Works Order : 53624
 EM Number : 62260
 Engineer : Marco Gmys
 Intersection : B2068 Old Dover Road / Nackington Road - Canterbury. 06/060

Special Instructions

ST800 CONTROLLER ITEMS LIST SHEET 2 (*I*L*)

ITEM	DRAWING NUMBER	DESCRIPTION	QTY	TOT	REMARKS
41					
42	667/1/27056/001	Manual Panel Assy (Intersection Cont)			
43	667/1/27056/010	Manual Panel Assy (Sigs on/off)			
44	667/1/27056/000	Manual Panel Blanking Kit			
45					
46					
47					
48					
49					
50					
51					
52	667/7/25171/000	Current Transformer			
53					
54					
55					
56					
57					
58					
59					
60					
61	667/1/27000/101	Cabinet Export 8 Phase wired 16 Phase			
62	667/1/27000/102	Cabinet Export 24 Phase wired 32 Phase			
63	667/1/27001/101	Rack Export 8 Phase wired 16 Phase			
64	667/1/27001/102	Rack Export 24 Phase wired 32 Phase			
65	667/1/27002/100	Export Lamp Switch Kit			
66	667/1/27084/001	Dimming Assembly (1.5KVA)(Fit Std UK)			
67	667/1/27084/002	Dimming Assembly (2.0KVA)			
68	667/1/27084/003	Dimming Assembly (3.0KVA)			
69	667/1/27130/000	30A Controller Kit			
70					
71	667/1/27001/310	ST800 SE Export Rack up to 8 Phase			
72	667/1/27223/003	ST800 SE 8 Phase Driver No LMU			
73	667/1/27223/403	ST800 SE 4 Phase Driver No LMU			
74					
75					
76					
77	667/1/27000/301	ST800 P In a Cabinet 4Ph 1 Stream PED			
78	667/1/27012/000	PED 2nd Stream Kit for ST800 P			
79	667/1/27001/300	ST800 P Rack Only 4Ph 1 Stream PED			

Note 2:
 Ancillary Processor PLD
 Variants
 101 OTU & LMU
 102 OTU Only
 103 LMU Only
 104 OTU & LMU + Up/Download
 105 OUT Only + Up/DownLoad
 NB Controller Has built in LMU
 So LMU on Ancillary Processor
 Not required included for info
 only.

Note 3:
 Fit Current Transformer
 starting from position
 TLB/z/16 on the first phase
 driver PCB. if more than 3
 sensors are called up fit the
 4th sensor to the second
 Phases driver PCB, and so on
 until all sensors have been
 used up.
 TLB/b/14 - 1st sensor terminal
 TLB/z/16 - 2nd sensor terminal
 TLB/z/14 - 3rd sensor terminal
 TLB/z/12 - 4th sensor terminal
 TLB/z/12 - 4th sensor terminal
 TLB/z/12 - 4th sensor terminal

Works Order : 53624
EM Number : 62260
Engineer : Marco Gmys
Intersection : B2068 Old Dover Road / Nackington Road - Canterbury. 06/060

Special Instructions

Works Order : 53624
EM Number : 62260
Engineer : Marco Gmys
Intersection : B2068 Old Dover Road / Nackington Road - Canterbury. 06/060

Special Instructions

LAMP MONITORING

=====

Lamp monitoring is provided by an external Microsense I2LM unit. Therefore the controllers lamp monitoring facilities are not being used and the red lamp monitoring functions are provided through special conditioning as described below:-

Dummy phase(s) I and J are duplicate of pedestrian phase(s) E and F. Any timing changes made to the real phase MUST be duplicated on the dummy phase. Note that the dummy phase does not need any leaving intergreens. The real ped phase is configured with a type 2 appearance code so conditioning can control when it appears and for this reason the PHD handset command MUST NOT be used for ped phase(s) E or F.

Under normal operation when the dummy phase goes to green it will demand the real phase which will then go straight to green. However if a 1st red lamp failure exists the demand is delayed by a PIR timer to give the extra intergreen. When a 2nd red lamp failure exists the demand will never occur. If a 2nd red lamp failure occurs during the ped green the real phase will be terminated once it's minimum green time has expired.

Lighting wait indicators and flashing the DFM lamp will operate as normal except that a DFM fault will cause the flashing to cease.

Lamp failure indications from the Microsense I2LM do not set the normal fault log flags so the special pedestrian fault flag (FLF23) has been used instead.

FLF23=1 indicates any lamp fail.
FLF23=2 indicates a 1st red lamp failure.
FLF23=4 indicates a 2nd red lamp failure.

Multiple failures will give a combination of these values, therefore it is easier to read if displayed in binary.

The I2LM fault outputs may be returned via the OTU to provide LF1 and LF2 replies.

I2LM CONNECTIONS

=====

Connect any lamp fail output to :LF 1TBR/6 - I/P61 & input common.

Connect 1st red lamp failure output to :RF1 1TBR/7 - I/P62 & input common.

Connect 2nd red lamp failure output to :RF2 1TBR/8 - I/P63 & input common.

NB. These outputs MUST be open circuit for active.

Works Order : 53624
EM Number : 62260
Engineer : Marco Gmys
Intersection : B2068 Old Dover Road / Nackington Road - Canterbury. 06/060

Call Cancel

Call Cancel

Unit No.	Input Name	Call Delay	Cancel Delay	Phase Demanded (Unlatched Demand)
0	BP	3	0	
1	DP	3	2	D
2	HC1	15	0	
3	HC2	15	0	
4		0	0	
5		0	0	
6		0	0	
7		0	0	

Inputs and Outputs

Inputs and Outputs

Enable Signal Required
 Check boxes

Port Number & Type

Port:

Inputs & Outputs

	DET No	Bit No	Type I or O	Name	Req'd	BP	Inv	U/D	Misc	DFM	DFM Group	Ext time	Phs	UTC	SDE	Pri	HC	CC	IG	UD	LRT	Term Block	Terminal No	
<input type="radio"/>	0	0	I	AX	<input checked="" type="checkbox"/>	<input type="checkbox"/>	<input type="checkbox"/>	<input type="checkbox"/>	<input type="checkbox"/>	A	0	0.0	<input checked="" type="checkbox"/>	<input type="checkbox"/>	<input type="checkbox"/>	<input type="checkbox"/>	<input type="checkbox"/>	<input type="checkbox"/>	<input type="checkbox"/>	<input type="checkbox"/>	<input type="checkbox"/>	<input type="checkbox"/>	1TBG	1
<input type="radio"/>	1	1	I	AY	<input checked="" type="checkbox"/>	<input type="checkbox"/>	<input type="checkbox"/>	<input type="checkbox"/>	<input type="checkbox"/>	A	0	0.0	<input checked="" type="checkbox"/>	<input type="checkbox"/>	<input type="checkbox"/>	<input type="checkbox"/>	<input type="checkbox"/>	<input type="checkbox"/>	<input type="checkbox"/>	<input type="checkbox"/>	<input type="checkbox"/>	<input type="checkbox"/>	1TBG	2
<input type="radio"/>	2	2	I	AZ	<input checked="" type="checkbox"/>	<input type="checkbox"/>	<input type="checkbox"/>	<input type="checkbox"/>	<input type="checkbox"/>	A	0	0.0	<input checked="" type="checkbox"/>	<input type="checkbox"/>	<input type="checkbox"/>	<input type="checkbox"/>	<input type="checkbox"/>	<input type="checkbox"/>	<input type="checkbox"/>	<input type="checkbox"/>	<input type="checkbox"/>	<input type="checkbox"/>	1TBG	3
<input type="radio"/>	3	3	I	BX	<input checked="" type="checkbox"/>	<input type="checkbox"/>	<input type="checkbox"/>	<input type="checkbox"/>	<input type="checkbox"/>	A	0	0.0	<input checked="" type="checkbox"/>	<input type="checkbox"/>	<input type="checkbox"/>	<input type="checkbox"/>	<input type="checkbox"/>	<input type="checkbox"/>	<input type="checkbox"/>	<input type="checkbox"/>	<input type="checkbox"/>	<input type="checkbox"/>	1TBG	4
<input type="radio"/>	4	4	I	BY	<input checked="" type="checkbox"/>	<input type="checkbox"/>	<input type="checkbox"/>	<input type="checkbox"/>	<input type="checkbox"/>	A	0	0.0	<input checked="" type="checkbox"/>	<input type="checkbox"/>	<input type="checkbox"/>	<input type="checkbox"/>	<input type="checkbox"/>	<input type="checkbox"/>	<input type="checkbox"/>	<input type="checkbox"/>	<input type="checkbox"/>	<input type="checkbox"/>	1TBG	5
<input type="radio"/>	5	5	I	BZ	<input checked="" type="checkbox"/>	<input type="checkbox"/>	<input type="checkbox"/>	<input type="checkbox"/>	<input type="checkbox"/>	A	0	0.0	<input checked="" type="checkbox"/>	<input type="checkbox"/>	<input type="checkbox"/>	<input type="checkbox"/>	<input type="checkbox"/>	<input type="checkbox"/>	<input type="checkbox"/>	<input type="checkbox"/>	<input type="checkbox"/>	<input type="checkbox"/>	1TBG	6
<input type="radio"/>	6	6	I	BP	<input checked="" type="checkbox"/>	<input type="checkbox"/>	<input type="checkbox"/>	<input type="checkbox"/>	<input type="checkbox"/>	A	0	0.0	<input type="checkbox"/>	<input type="checkbox"/>	<input type="checkbox"/>	<input type="checkbox"/>	<input type="checkbox"/>	<input type="checkbox"/>	<input checked="" type="checkbox"/>	<input type="checkbox"/>	<input type="checkbox"/>	<input type="checkbox"/>	1TBG	7
<input type="radio"/>	7	7	I	CX	<input checked="" type="checkbox"/>	<input type="checkbox"/>	<input type="checkbox"/>	<input type="checkbox"/>	<input type="checkbox"/>	A	0	0.0	<input checked="" type="checkbox"/>	<input type="checkbox"/>	<input type="checkbox"/>	<input type="checkbox"/>	<input type="checkbox"/>	<input type="checkbox"/>	<input type="checkbox"/>	<input type="checkbox"/>	<input type="checkbox"/>	<input type="checkbox"/>	1TBG	8

Inputs and Outputs

Inputs and Outputs

Enable Signal Required
 Check boxes

Port Number & Type

Port:

Inputs & Outputs

	DET No	Bit No	Type I or O	Name	Req'd	BP	Inv	U/D	Misc	DFM	DFM Group	Ext time	Phs	UTC	SDE	Pri	HC	CC	IG	UD	LRT	Term Block	Terminal No	
<input type="radio"/>	8	0	I	CY	<input checked="" type="checkbox"/>	<input type="checkbox"/>	<input type="checkbox"/>	<input type="checkbox"/>	<input type="checkbox"/>	A	0	0.0	<input checked="" type="checkbox"/>	<input type="checkbox"/>	<input type="checkbox"/>	<input type="checkbox"/>	<input type="checkbox"/>	<input type="checkbox"/>	<input type="checkbox"/>	<input type="checkbox"/>	<input type="checkbox"/>	<input type="checkbox"/>	1TBH	1
<input type="radio"/>	9	1	I	CZ	<input checked="" type="checkbox"/>	<input type="checkbox"/>	<input type="checkbox"/>	<input type="checkbox"/>	<input type="checkbox"/>	A	0	0.0	<input checked="" type="checkbox"/>	<input type="checkbox"/>	<input type="checkbox"/>	<input type="checkbox"/>	<input type="checkbox"/>	<input type="checkbox"/>	<input type="checkbox"/>	<input type="checkbox"/>	<input type="checkbox"/>	<input type="checkbox"/>	1TBH	2
<input type="radio"/>	10	2	I	DX	<input checked="" type="checkbox"/>	<input type="checkbox"/>	<input type="checkbox"/>	<input type="checkbox"/>	<input type="checkbox"/>	A	0	0.0	<input type="checkbox"/>	<input type="checkbox"/>	<input type="checkbox"/>	<input type="checkbox"/>	<input type="checkbox"/>	<input type="checkbox"/>	<input type="checkbox"/>	<input type="checkbox"/>	<input type="checkbox"/>	<input type="checkbox"/>	1TBH	3
<input type="radio"/>	11	3	I	DY	<input checked="" type="checkbox"/>	<input type="checkbox"/>	<input type="checkbox"/>	<input type="checkbox"/>	<input type="checkbox"/>	A	0	0.0	<input type="checkbox"/>	<input type="checkbox"/>	<input type="checkbox"/>	<input type="checkbox"/>	<input type="checkbox"/>	<input type="checkbox"/>	<input type="checkbox"/>	<input type="checkbox"/>	<input type="checkbox"/>	<input type="checkbox"/>	1TBH	4
<input type="radio"/>	12	4	I	DZ	<input checked="" type="checkbox"/>	<input type="checkbox"/>	<input type="checkbox"/>	<input type="checkbox"/>	<input type="checkbox"/>	A	0	0.0	<input type="checkbox"/>	<input type="checkbox"/>	<input type="checkbox"/>	<input type="checkbox"/>	<input type="checkbox"/>	<input type="checkbox"/>	<input type="checkbox"/>	<input type="checkbox"/>	<input type="checkbox"/>	<input type="checkbox"/>	1TBH	5
<input type="radio"/>	13	5	I	DP	<input checked="" type="checkbox"/>	<input type="checkbox"/>	<input type="checkbox"/>	<input type="checkbox"/>	<input type="checkbox"/>	A	0	0.0	<input checked="" type="checkbox"/>	<input type="checkbox"/>	<input type="checkbox"/>	<input type="checkbox"/>	<input type="checkbox"/>	<input checked="" type="checkbox"/>	<input type="checkbox"/>	<input type="checkbox"/>	<input type="checkbox"/>	<input type="checkbox"/>	1TBH	6
<input type="radio"/>	14	6	I	AR1	<input checked="" type="checkbox"/>	<input type="checkbox"/>	<input type="checkbox"/>	<input type="checkbox"/>	<input type="checkbox"/>	A	0	1.4	<input type="checkbox"/>	<input type="checkbox"/>	<input type="checkbox"/>	<input type="checkbox"/>	<input type="checkbox"/>	<input type="checkbox"/>	<input checked="" type="checkbox"/>	<input type="checkbox"/>	<input type="checkbox"/>	<input type="checkbox"/>	1TBH	7
<input type="radio"/>	15	7	I	HC1	<input checked="" type="checkbox"/>	<input type="checkbox"/>	<input type="checkbox"/>	<input type="checkbox"/>	<input type="checkbox"/>	I	0	0.0	<input type="checkbox"/>	<input type="checkbox"/>	<input type="checkbox"/>	<input type="checkbox"/>	<input type="checkbox"/>	<input checked="" type="checkbox"/>	<input type="checkbox"/>	<input type="checkbox"/>	<input type="checkbox"/>	<input type="checkbox"/>	1TBH	8

Add

Delete

Move

Clear Used By

Inputs and Outputs

Inputs and Outputs

Enable Signal Required
 Check boxes

Port Number & Type

Port:

6



Inputs & Outputs

	DET No	Bit No	Type I or O	Name	Req'd	BP	Inv	U/D	Misc	DFM	DFM Group	Ext time	Phs	UTC	SDE	Pri	HC	CC	IG	UD	LRT	Term Block	Terminal No
<input type="radio"/>	48	0	I	HC2	<input checked="" type="checkbox"/>	<input type="checkbox"/>	<input type="checkbox"/>	<input type="checkbox"/>	<input type="checkbox"/>	I	0	0.0	<input type="checkbox"/>	<input type="checkbox"/>	<input type="checkbox"/>	<input type="checkbox"/>	<input type="checkbox"/>	<input checked="" type="checkbox"/>	<input type="checkbox"/>	<input type="checkbox"/>	<input type="checkbox"/>	1TBN	1
<input type="radio"/>	49	1	I	MVD3	<input checked="" type="checkbox"/>	<input type="checkbox"/>	<input type="checkbox"/>	<input type="checkbox"/>	<input type="checkbox"/>	A	0	0.0	<input type="checkbox"/>	<input type="checkbox"/>	<input type="checkbox"/>	<input type="checkbox"/>	<input type="checkbox"/>	<input type="checkbox"/>	<input checked="" type="checkbox"/>	<input type="checkbox"/>	<input type="checkbox"/>	1TBN	2
<input type="radio"/>	50	2	I	MVD6	<input checked="" type="checkbox"/>	<input type="checkbox"/>	<input type="checkbox"/>	<input type="checkbox"/>	<input type="checkbox"/>	A	0	0.0	<input type="checkbox"/>	<input type="checkbox"/>	<input type="checkbox"/>	<input type="checkbox"/>	<input type="checkbox"/>	<input type="checkbox"/>	<input checked="" type="checkbox"/>	<input type="checkbox"/>	<input type="checkbox"/>	1TBN	3
<input type="radio"/>	51	3	I	PB3E	<input checked="" type="checkbox"/>	<input type="checkbox"/>	<input type="checkbox"/>	<input type="checkbox"/>	<input type="checkbox"/>	A	1	0.0	<input checked="" type="checkbox"/>	<input type="checkbox"/>	<input type="checkbox"/>	<input type="checkbox"/>	<input type="checkbox"/>	<input type="checkbox"/>	<input type="checkbox"/>	<input type="checkbox"/>	<input type="checkbox"/>	1TBN	4
<input type="radio"/>	52	4	I	PB4E	<input checked="" type="checkbox"/>	<input type="checkbox"/>	<input type="checkbox"/>	<input type="checkbox"/>	<input type="checkbox"/>	A	1	0.0	<input checked="" type="checkbox"/>	<input type="checkbox"/>	<input type="checkbox"/>	<input type="checkbox"/>	<input type="checkbox"/>	<input type="checkbox"/>	<input type="checkbox"/>	<input type="checkbox"/>	<input type="checkbox"/>	1TBN	5
<input type="radio"/>	53	5	I	PB6F	<input checked="" type="checkbox"/>	<input type="checkbox"/>	<input type="checkbox"/>	<input type="checkbox"/>	<input type="checkbox"/>	A	1	0.0	<input checked="" type="checkbox"/>	<input type="checkbox"/>	<input type="checkbox"/>	<input type="checkbox"/>	<input type="checkbox"/>	<input type="checkbox"/>	<input type="checkbox"/>	<input type="checkbox"/>	<input type="checkbox"/>	1TBN	6
<input type="radio"/>	54	6	I	PB7F	<input checked="" type="checkbox"/>	<input type="checkbox"/>	<input type="checkbox"/>	<input type="checkbox"/>	<input type="checkbox"/>	A	1	0.0	<input checked="" type="checkbox"/>	<input type="checkbox"/>	<input type="checkbox"/>	<input type="checkbox"/>	<input type="checkbox"/>	<input type="checkbox"/>	<input type="checkbox"/>	<input type="checkbox"/>	<input type="checkbox"/>	1TBN	7
<input type="radio"/>	55	7	I	BPA	<input checked="" type="checkbox"/>	<input type="checkbox"/>	<input type="checkbox"/>	<input type="checkbox"/>	<input type="checkbox"/>	I	2	0.0	<input checked="" type="checkbox"/>	<input type="checkbox"/>	<input type="checkbox"/>	<input checked="" type="checkbox"/>	<input type="checkbox"/>	<input type="checkbox"/>	<input type="checkbox"/>	<input type="checkbox"/>	<input type="checkbox"/>	1TBN	8

Add

Delete

Move

Clear Used By

Inputs and Outputs

Inputs and Outputs

Enable Signal Required
 Check boxes

Port Number & Type

Port:

Inputs & Outputs

	DET No	Bit No	Type I or O	Name	Req'd	BP	Inv	U/D	Misc	DFM	DFM Group	Ext time	Phs	UTC	SDE	Used By				Pri	HC	CC	IG	UD	LRT	Term Block	Terminal No
<input type="radio"/>	56	0	I	BPB	<input checked="" type="checkbox"/>	<input type="checkbox"/>	<input type="checkbox"/>	<input type="checkbox"/>	<input type="checkbox"/>	<input type="text" value="1"/>	<input type="text" value="2"/>	<input type="text" value="0.0"/>	<input checked="" type="checkbox"/>	<input type="checkbox"/>	<input type="checkbox"/>	<input checked="" type="checkbox"/>	<input type="checkbox"/>	<input type="checkbox"/>	<input type="checkbox"/>	<input type="checkbox"/>	<input type="checkbox"/>	<input type="checkbox"/>	<input type="checkbox"/>	<input type="checkbox"/>	<input type="checkbox"/>	1TBR	1
<input type="radio"/>	57	1	I	BPC	<input checked="" type="checkbox"/>	<input type="checkbox"/>	<input type="checkbox"/>	<input type="checkbox"/>	<input type="checkbox"/>	<input type="text" value="1"/>	<input type="text" value="2"/>	<input type="text" value="0.0"/>	<input checked="" type="checkbox"/>	<input type="checkbox"/>	<input type="checkbox"/>	<input checked="" type="checkbox"/>	<input type="checkbox"/>	<input type="checkbox"/>	<input type="checkbox"/>	<input type="checkbox"/>	<input type="checkbox"/>	<input type="checkbox"/>	<input type="checkbox"/>	<input type="checkbox"/>	<input type="checkbox"/>	1TBR	2
<input type="radio"/>	58	2	I	BPD	<input checked="" type="checkbox"/>	<input type="checkbox"/>	<input type="checkbox"/>	<input type="checkbox"/>	<input type="checkbox"/>	<input type="text" value="1"/>	<input type="text" value="2"/>	<input type="text" value="0.0"/>	<input checked="" type="checkbox"/>	<input type="checkbox"/>	<input type="checkbox"/>	<input checked="" type="checkbox"/>	<input type="checkbox"/>	<input type="checkbox"/>	<input type="checkbox"/>	<input type="checkbox"/>	<input type="checkbox"/>	<input type="checkbox"/>	<input type="checkbox"/>	<input type="checkbox"/>	<input type="checkbox"/>	1TBR	3
<input type="radio"/>	59	3	I	CANCLHC0	<input checked="" type="checkbox"/>	<input type="checkbox"/>	<input type="checkbox"/>	<input type="checkbox"/>	<input type="checkbox"/>	<input type="text" value="N"/>	<input type="text"/>	<input type="text" value="0.0"/>	<input type="checkbox"/>	<input type="checkbox"/>	<input type="checkbox"/>	<input type="checkbox"/>	<input checked="" type="checkbox"/>	<input type="checkbox"/>	<input type="checkbox"/>	<input type="checkbox"/>	<input type="checkbox"/>	<input type="checkbox"/>	<input type="checkbox"/>	<input type="checkbox"/>	<input type="checkbox"/>	1TBR	4
<input type="radio"/>	60	4	I		<input type="checkbox"/>	<input type="checkbox"/>	<input type="checkbox"/>	<input type="checkbox"/>	<input type="checkbox"/>				<input type="checkbox"/>	<input type="checkbox"/>	<input type="checkbox"/>	<input type="checkbox"/>	<input type="checkbox"/>	<input type="checkbox"/>	<input type="checkbox"/>	<input type="checkbox"/>	<input type="checkbox"/>	<input type="checkbox"/>	<input type="checkbox"/>	<input type="checkbox"/>	<input type="checkbox"/>	1TBR	5
<input type="radio"/>	61	5	I	LF	<input checked="" type="checkbox"/>	<input type="checkbox"/>	<input checked="" type="checkbox"/>	<input type="checkbox"/>	<input type="checkbox"/>	<input type="text" value="N"/>	<input type="text"/>	<input type="text" value="0.0"/>	<input type="checkbox"/>	<input type="checkbox"/>	<input type="checkbox"/>	<input type="checkbox"/>	<input type="checkbox"/>	<input type="checkbox"/>	<input type="checkbox"/>	<input type="checkbox"/>	<input type="checkbox"/>	<input type="checkbox"/>	<input type="checkbox"/>	<input type="checkbox"/>	<input type="checkbox"/>	1TBR	6
<input type="radio"/>	62	6	I	RF1	<input checked="" type="checkbox"/>	<input type="checkbox"/>	<input checked="" type="checkbox"/>	<input type="checkbox"/>	<input type="checkbox"/>	<input type="text" value="N"/>	<input type="text"/>	<input type="text" value="0.0"/>	<input type="checkbox"/>	<input type="checkbox"/>	<input type="checkbox"/>	<input type="checkbox"/>	<input type="checkbox"/>	<input type="checkbox"/>	<input type="checkbox"/>	<input type="checkbox"/>	<input type="checkbox"/>	<input type="checkbox"/>	<input type="checkbox"/>	<input type="checkbox"/>	<input type="checkbox"/>	1TBR	7
<input type="radio"/>	63	7	I	RF2	<input checked="" type="checkbox"/>	<input type="checkbox"/>	<input checked="" type="checkbox"/>	<input type="checkbox"/>	<input type="checkbox"/>	<input type="text" value="N"/>	<input type="text"/>	<input type="text" value="0.0"/>	<input type="checkbox"/>	<input type="checkbox"/>	<input type="checkbox"/>	<input type="checkbox"/>	<input type="checkbox"/>	<input type="checkbox"/>	<input type="checkbox"/>	<input type="checkbox"/>	<input type="checkbox"/>	<input type="checkbox"/>	<input type="checkbox"/>	<input type="checkbox"/>	<input type="checkbox"/>	1TBR	8

Works Order : 53624
 EM Number : 62260
 Engineer : Marco Gmys
 Intersection : B2068 Old Dover Road / Nackington Road - Canterbury. 06/060

Aspect Drives

Aspect Drives

A-L M-X Y-F2

Phase Driver Card 1			
	Used For	Term Block	Term No
A - Red	Phase	1TBA	1
A - Amber	Phase	1TBA	2
A - Green	Phase	1TBA	3
B - Red	Phase	1TBA	4
B - Amber	Phase	1TBA	5
B - Green	Phase	1TBA	6
C - Red	Phase	1TBA	7
C - Amber	Phase	1TBA	8
C - Green	Phase	1TBA	9
D - Red	Phase	1TBA	10
D - Amber	Phase	1TBA	11
D - Green	Phase	1TBA	12

Phase Driver Card 1			
	Used For	Term Block	Term No
E - Red	Phase	1TBB	1
E - Amber	Phase	1TBB	2
E - Green	Phase	1TBB	3
F - Red	Phase	1TBB	4
F - Amber	Phase	1TBB	5
F - Green	Phase	1TBB	6
G - Red			
G - Amber			
G - Green			
H - Red			
H - Amber			
H - Green			

Phase Driver Card 2			
	Used For	Term Block	Term No
I - Red			
I - Amber			
I - Green			
J - Red			
J - Amber			
J - Green			
K - Red			
K - Amber			
K - Green			
L - Red			
L - Amber			
L - Green			

I/O - DFM Group Timings

I/O - DFM Group Timings

Input Group	State	SET A	SET B	SET C	SET D
Group 0	Active (Mins)	<input type="text" value="60"/>	<input type="text" value="60"/>	<input type="text" value="60"/>	<input type="text" value="60"/>
	InActive (Hrs)	<input type="text" value="18"/>	<input type="text" value="18"/>	<input type="text" value="18"/>	<input type="text" value="18"/>
Group 1	Active (Mins)	<input type="text" value="60"/>	<input type="text" value="60"/>	<input type="text" value="60"/>	<input type="text" value="60"/>
	InActive (Hrs)	<input type="text"/>	<input type="text"/>	<input type="text"/>	<input type="text"/>
Group 2	Active (Mins)	<input type="text" value="10"/>	<input type="text" value="10"/>	<input type="text" value="10"/>	<input type="text" value="10"/>
	InActive (Hrs)	<input type="text"/>	<input type="text"/>	<input type="text"/>	<input type="text"/>
Group 3	Active (Mins)	<input type="text" value="30"/>	<input type="text" value="30"/>	<input type="text" value="30"/>	<input type="text" value="30"/>
	InActive (Hrs)	<input type="text" value="18"/>	<input type="text" value="18"/>	<input type="text" value="18"/>	<input type="text" value="18"/>
Group 4	Active (Mins)	<input type="text" value="30"/>	<input type="text" value="30"/>	<input type="text" value="30"/>	<input type="text" value="30"/>
	InActive (Hrs)	<input type="text" value="18"/>	<input type="text" value="18"/>	<input type="text" value="18"/>	<input type="text" value="18"/>
Group 5	Active (Mins)	<input type="text" value="30"/>	<input type="text" value="30"/>	<input type="text" value="30"/>	<input type="text" value="30"/>
	InActive (Hrs)	<input type="text" value="18"/>	<input type="text" value="18"/>	<input type="text" value="18"/>	<input type="text" value="18"/>
Group 6	Active (Mins)	<input type="text" value="30"/>	<input type="text" value="30"/>	<input type="text" value="30"/>	<input type="text" value="30"/>
	InActive (Hrs)	<input type="text" value="18"/>	<input type="text" value="18"/>	<input type="text" value="18"/>	<input type="text" value="18"/>
Group 7	Active (Mins)	<input type="text" value="30"/>	<input type="text" value="30"/>	<input type="text" value="30"/>	<input type="text" value="30"/>
	InActive (Hrs)	<input type="text" value="18"/>	<input type="text" value="18"/>	<input type="text" value="18"/>	<input type="text" value="18"/>

Note - 255 or blank disables DFM monitoring of that state (active or inactive) during that timeset (A to D)

Handset Limiting Values

State	Min	Max
Active (Mins)	<input type="text" value="0"/>	<input type="text" value="254"/>
InActive (Hrs)	<input type="text" value="0"/>	<input type="text" value="254"/>

Index

- 1 General Junction Data
 - 1.1 Administration
 - 1.2 Phases, Stages and Streams
 - 1.3 Facilities/Modes Enabled and Mode Priority Levels
 - 1.4 Phases in Stages
 - 1.5 Stages in Streams
- 2 Phases
 - 2.1 Phase Type and Conditions
 - 2.2 Opposing and Conflicting Phases
 - 2.3 Timings
 - 2.3.1 Phase Minimums, Maximums, Extensions, Ped Leaving Periods
 - 2.3.2 Phase Intergreen Times
 - 2.3.3 Intergreen Handset Limits
 - 2.3.4 Phase Timing Handset Ranges
 - 2.4 VA Demand and Extend Definitions
 - 2.5 Phase Internal/Revertive Demands
- 3 Stage Movements
 - 3.1 Stages - Prohibited, Alternative, Ignored Moves
 - 3.2 Stage Internal Demands/Pedestrian Window Times
 - 3.3 Phase Delays (No configuration data to print)
- 4 Modes and Facilities - Detailed
 - 4.1 Fixed Time
 - 4.2 Cableless Linking
 - 4.2.1 CLF - Plan(s) (No configuration data to print)
 - 4.2.2 CLF - Demand Dependent Moves
 - 4.3 UTC and MOVA
 - 4.3.1 UTC General Data
 - 4.3.2 UTC Control and Reply Data Format
 - 4.3.3 UTC Data Definitions
 - 4.3.3.1 UTC Phase Demand and Extend Definitions
 - 4.3.3.2 UTC Stage and Mode Data Definitions
 - 4.3.3.3 UTC Demand Dependent Forces
 - 4.3.4 UTC and MOVA Detectors (No configuration data to print)
 - 4.4 Master Time Clock
 - 4.4.1 MTC - Time Switch Parameters
 - 4.4.2 MTC - Time Switch Parameters Array
 - 4.4.3 MTC - Day Type
 - 4.4.4 MTC - Timetable
 - 4.5 Priority and Emergency Vehicle
 - 4.5.1 Priority and Emergency Vehicle - General
 - 4.5.2 Priority - Delays, Unit Inhibits and Associations
 - 4.5.3 Priority Time Sets
 - 4.5.4 Priority - Allowed and Enforced Demands
 - 4.6 Hurry Call
 - 4.7 Manual
 - 4.7.1 Manual Panel
 - 4.7.2 Manual Mode - Optional Phases Appearance
 - 4.8 Extend All Red
 - 4.8.1 Extend All Red - General
 - 4.8.2 Extend All Red - Stage To Stage Moves
 - 4.8.3 Extend All Red - Independent Intergreens
- 5 Conditioning Data
 - 5.1 Special Conditioning
 - 5.2 Special Conditioning Timers
 - 5.3 Fault Log Flags (No configuration data to print)
- 6 Special Instructions
- 7 I/O
 - 7.1 Call Cancel
 - 7.2 Inputs and Outputs
 - 7.3 Aspect Drives
 - 7.4 I/O - DFM Group Timings



TRAFFIC SIGNAL DATA SHEET

REF NO	06/0061	SITE	B2068 Old Dover Road/ St Lawrence	TOWN	Canterbury
--------	----------------	------	--	------	-------------------

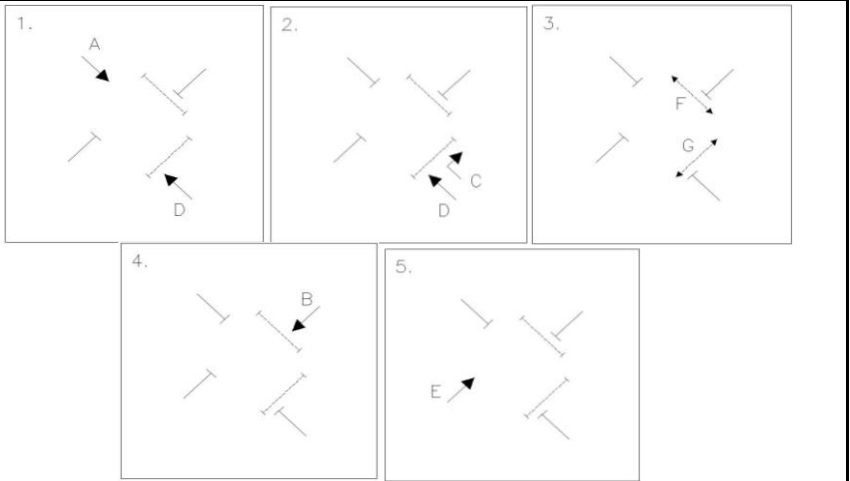
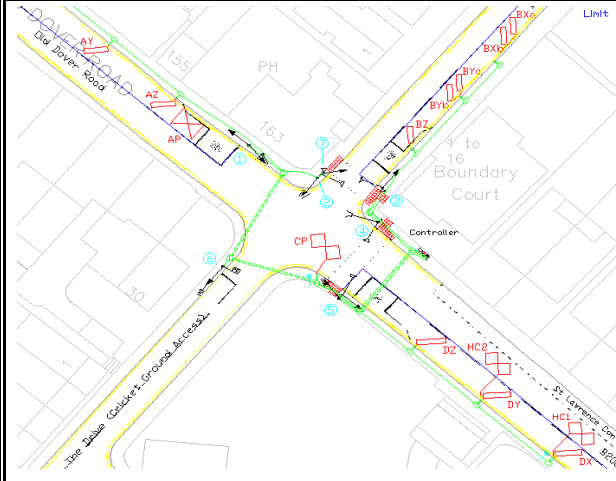

APPROACH	PHASE	MIN	PED B/OUT	EXT	MAX A	MAX B	MAX C	MAX D	DEMANDED BY		EXTENDED BY	
									DET NO	DET NAME	DET NO	DET NAME
Old Dover Road NW	A	7		1.6	30	20	40	20	0,1,2,55	AX,AY,AZ,AP,BPA	0,1,2	AX,AY,AZ
St Lawrence Road	B	7		1.0	20	15	15	12	4,6,8,56	BX,BY,BZ,BPB	4,6,8	BX,BY,BZ
Old Dover Road SE RT	C	4			15	10	10	10	9,57	CP,BPC	9	CP
Old Dover Road SE	D	7		1.6	60	40	45	20	10,11,12,58	DX,DY,DZ,BPD	10,11,12	DX,DY,DZ
The Drive	E	7		0.6	12	12	12	12	13	EP	49	MVD6
Peds across St Lawrence Road	F	6	4						50,51	PB2F,PB3F		
Peds across Old Dover Road SE	G	6	7						52,53	PB4G,PB5G		
Dummy All-red	H	1			1	1	1	1				
Dummy for stage 3	I	3										
	J											
	K											
	L											
	M											
	N											
	O											
	P											

STAGE INTERGREEN TIMES											ADDITIONAL PHASE DELAYS					SPECIAL FEATURES
TO FROM	1	2	3	4	5	6	7	8	9	10	NO	DELAY PHASE	FROM STAGE	TO STAGE	BY (SECS)	
1		5	8*	6	6						1					
2	6		8*	5	6						2					
3	12	12		12	12						3					
4	5	5	7		6						4					
5	5	5	8*	5							5					
6											6					
7											7					
8											8					
9											9					
10											10					

Hurry call is demanded by both HC1 and HC2 being active
 BX & BY are unidirectional
 CP has a 3s call, 2s cancel
 EP has a 3s call, 0s cancel
 AP has a 3s call, 0s cancel
 BZ has a 3s call, 0s cancel

* Intergreen can be increased by 8s in 0.6s steps for MVD4 & 2.0s steps for CP

DETECTOR MONITOR (AS SEEN ON ENGINEERS TERMINAL)									HURRY CALLS						SPECIAL FEATURES
IOP	7	6	5	4	3	2	1	0	HC	STAGE	DEM'D	CALL DELAY	HOLD	P'VENT	
0	BYu	BY	BXu	BX	AP	AZ	AY	AX	1	2	#	0	15	8	
1	HC2	HC1	EP	DZ	DY	DX	CP	BZ	2						
3					CANCLH00										
6	BPA		PB5G	PB4G	PB3F	PB2F	MVD6	MVD4	BUS PRIORITY DATA						
7	RF2	RF1	LF			BPD	BPC	BPB	UNIT	PHASE	EXT	MAX	COMP	INHIBIT	DFM(s)
									0	A	10	30		120	600
									1	B	10	30		120	600
									2	C	10	30		120	600
									3	D	10	30		120	600

Stage 2 to 1 via all red

M-F 0730 Max A
 M-F 0930 Max B
 M-F 1500 Max C
 M-F 1830 Max D
 Sat 0730 Max B
 Sat 1900 Max D
 Sun 0830 Max B
 Sun 1830 Max D

REVERSION STAGE	DFM PERIOD (HRS)	STARTING INTERGR'N (S)	F.T. TO CURRENT	F.T. MODE STAGE GREEN TIME	COMMISSIONED/INITLS	23/05/03	PC	MANUAL CONTROL	OTU X No	X31220
1	18	12	<input checked="" type="checkbox"/>		CONFIG NUMBER	E66221	IB	PB	LINK LIST	
					DATA PREPARED/INITLS	19/11/15		STAGE	BT CIRCUIT	01227 478268
					FILE REFERENCE	06/0061			AutoCAD file	06-0061-01 As Built

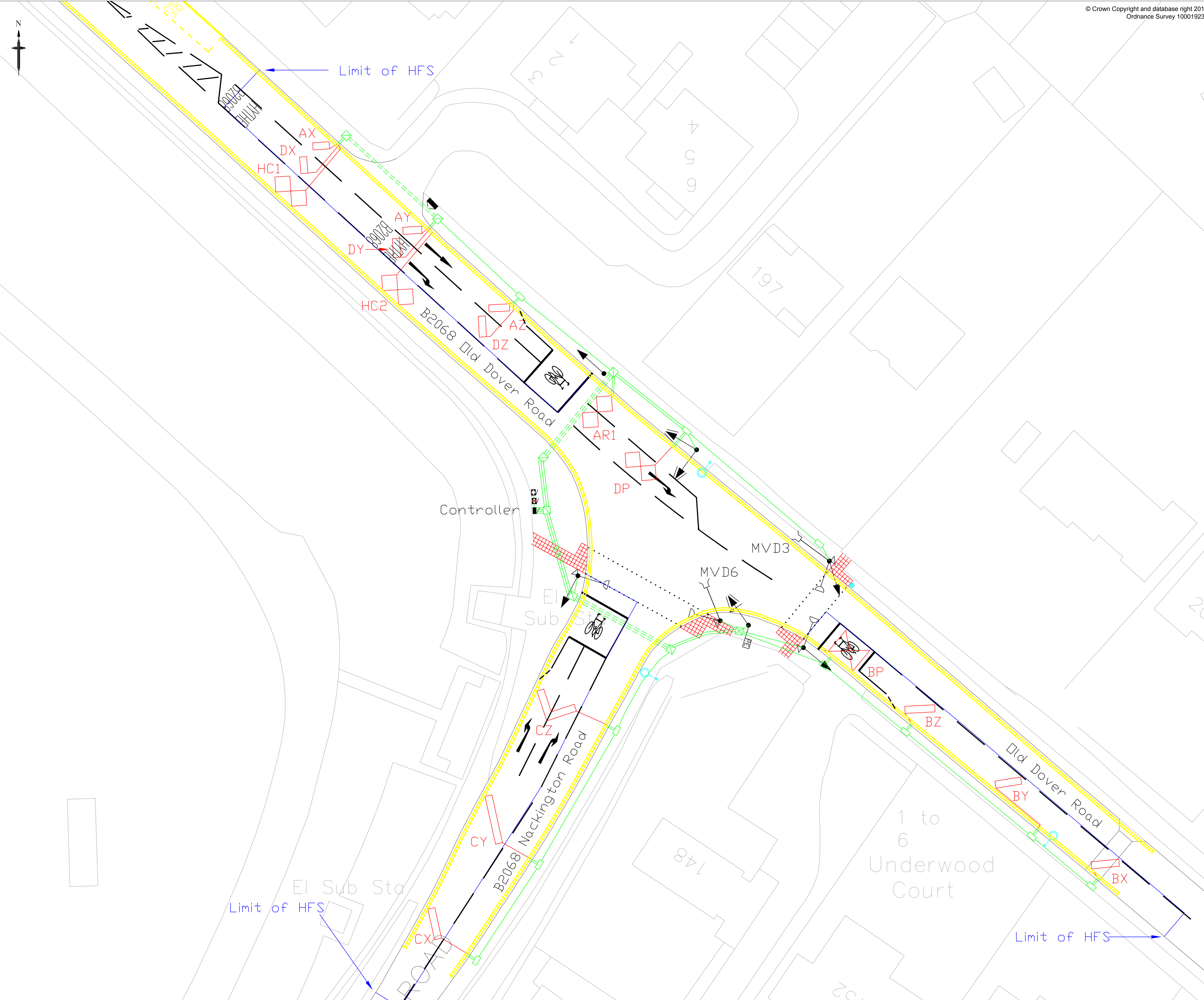

Key

- Junction box 550 mm depth (no under kerb ducts)
- Junction box 550 mm depth (with under kerb ducts)
- Junction pit 900 mm depth (no under kerb ducts)
- Junction pit 900 mm depth (with under kerb ducts)
- Junction pit 550 mm depth (no under kerb ducts)
- Junction pit 550 mm depth (with under kerb ducts)
- Duct FW/1 100 mm dia
- Duct FW/2 100 mm dia
- Duct FW/3 100 mm dia
- Duct CW/2 100 mm dia
- Duct CW/3 100 mm dia
- Duct CW/4 100 mm dia
- Signal controller cabinet
- Electricity supply pillar
- BT termination pillar
- Vehicle detector loop and identity
- Traffic signal and pole
- Traffic signal with secondary hoods
- Pedestrian signal
- Pedestrian push button unit
- Microwave vehicle detector
- Pedestrian / cycle on crossing detector
- Visual pedestrian or vehicle presence detector
- Photo electric cell
- Bus priority receiver
- Layout of blister tactile surface modules (red)
- Roadstuds
- Existing lighting column
- HFS (HFS beyond stopline must be coloured Grey)

- Notes**
1. This drawing is based on Ordnance Survey digital data supplemented by additional base detail measured on site. Original drawing 2861/5/1C.
 2. High Friction Surface (HFS) shall extend 50m in advance of the stopline on each approach.
The HFS shall extend to the first row of pedestrian studs beyond the stopline. On High Speed Roads, the HFS shall extend to the second row of pedestrian studs beyond the stopline. All HFS beyond the stopline shall be coloured grey.
 3. This drawing shall be read in conjunction with KCC Standard Details-
KCC/400/002 - Pedestrian guardrail.
KCC/500/020 to /025 - Ducting and Junction Pits.
KCC/1100/007 - Tactile paving at controlled pedestrian crossing points.
KCC/1200/007 and /008 - Installation of signal equipment.
KCC/1200/009 - Traffic Signal Pole Retention Socket.
 4. This drawing shall be read in conjunction with the Contract Specification
Appendices-
Appendix 5/2 - Service Duct requirements.
Appendix 12/3 - Traffic Signs: Studs.
Appendix 12/5 - Traffic Signs: Traffic Signals.
Appendix 14/5 - Electrical Equipment.
 5. Ducting shall be adjusted locally to avoid existing Statutory Undertakers Plant.
 6. The details of any existing services shown on this drawing are based upon information supplied by the statutory bodies and other authorities concerned. The accuracy of this information cannot be guaranteed and the presence of other apparatus, in particular service connections to individual properties, should be expected.
 7. Bus priority cable shall terminate in Pole 2 and be tagged at the pole and controller 'Bus Priority'.

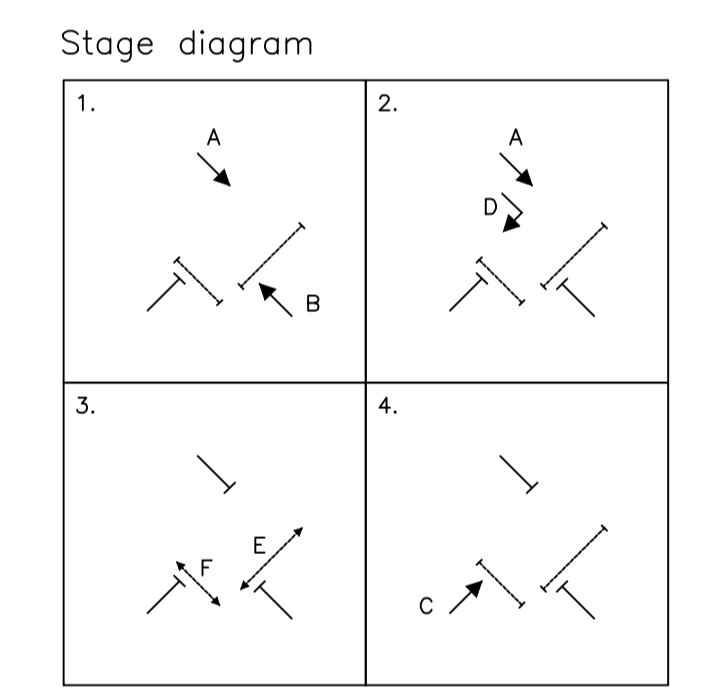

0	19/10/15	As built Transferred to current frame	IB		
Rev	Revision Date	Purpose of revision	Drawn	Checked	Approved



Kent County Council
Aylesford Highway Depot
St. Michael's Close
Aylesford ME20 7BU
Tel: 03000 41 81 81

Project: **Intelligent Transport Systems**

Drawing title: **B2068 Old Dover Road/ Nackington Road, Canterbury Site Ref 06/0060**

Drawing status: **As Built**

Scale: **1:200 at A1** **Do not scale**

Drawing number: **ITS/2015/S/06-0060** Rev: **0**

This drawing is not to be used in whole or part other than for the intended purpose and project as defined on this drawing. Refer to the contract for full terms and conditions.

APPENDIX C

2018 Base LinSig Model Outputs

Full Input Data And Results

User and Project Details

Project:	
Title:	
Location:	
Additional detail:	
File name:	Old_Dover_Road_Cantebury_Base_Model_v0.1.lsg3x
Author:	
Company:	
Address:	

Network Layout Diagram

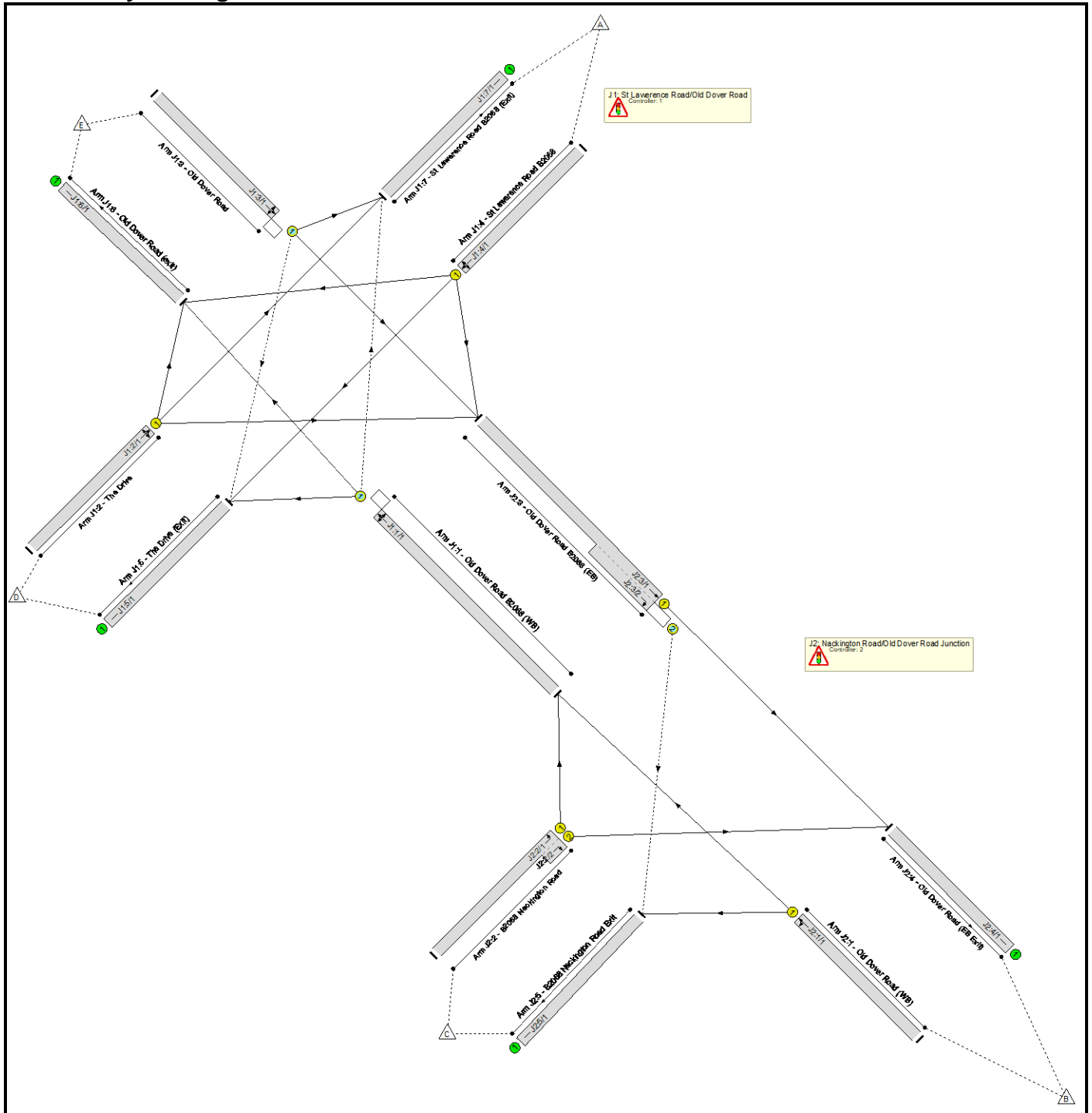

C1 - B2068 Old Dover / St Lawrence Rd, Canterbury. 06/0
Phase Diagram

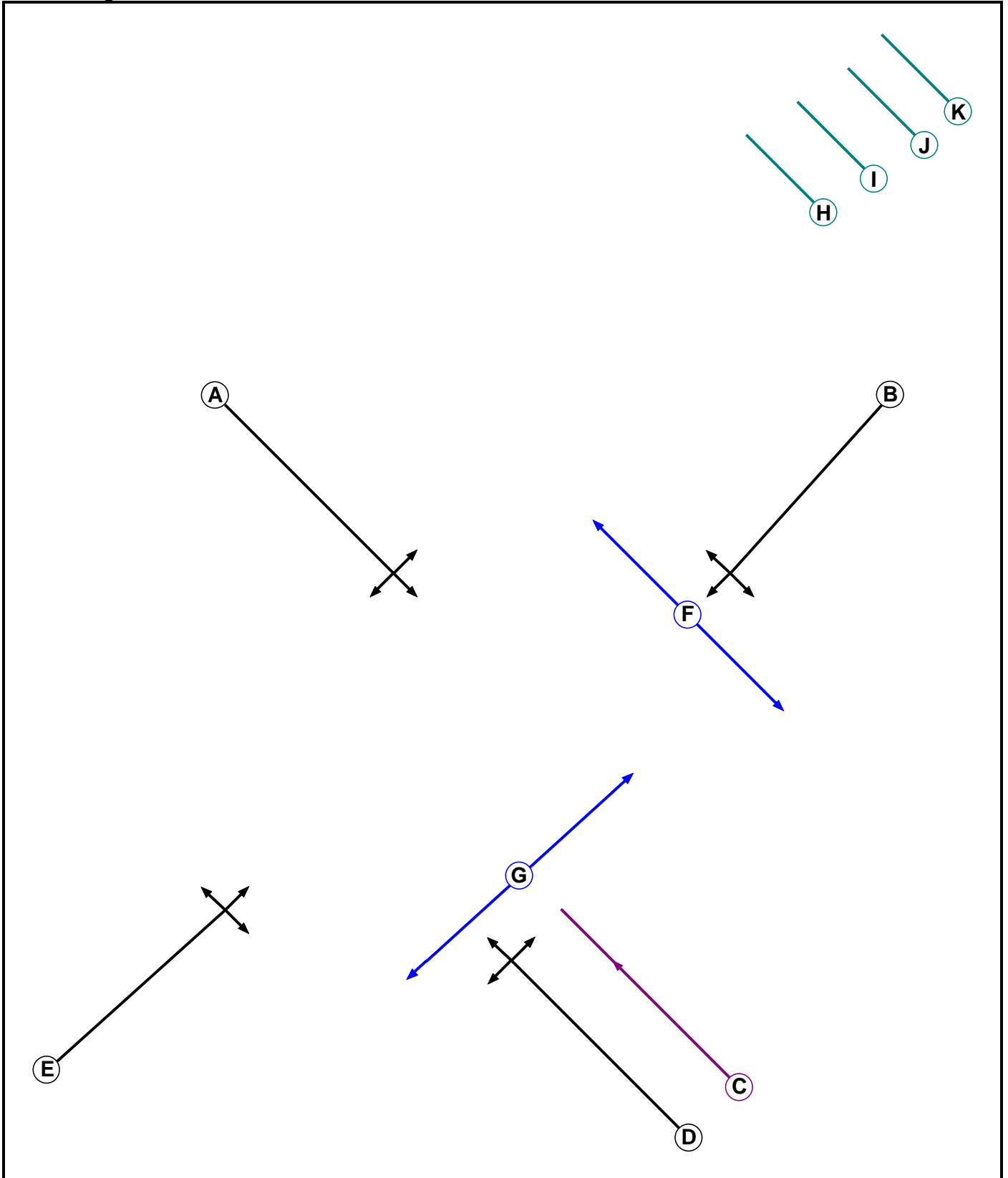

Full Input Data And Results

Phase Input Data

Phase Name	Phase Type	Assoc. Phase	Street Min	Cont Min
A	Traffic		-9999	7
B	Traffic		-9999	7
C	Ind. Arrow	D	-9999	4
D	Traffic		-9999	7
E	Traffic		-9999	7
F	Pedestrian		-9999	6
G	Pedestrian		-9999	6
H	Dummy		-9999	1
I	Dummy		-9999	3
J	Dummy		-9999	6
K	Dummy		-9999	6

Phase Intergreens Matrix

		Starting Phase										
		A	B	C	D	E	F	G	H	I	J	K
Terminating Phase	A		6	5	-	6	8	8	3	8	8	8
	B	5		5	5	6	5	7	3	7	5	7
	C	6	5		-	6	8	5	3	8	8	5
	D	-	5	-		6	8	5	3	8	8	5
	E	5	5	5	5		7	8	3	8	7	8
	F	8	8	8	8	8		-	4	-	-	-
	G	12	12	12	12	12	-		7	-	-	-
	H	0	0	3	3	0	0	0		-	-	-
	I	-	-	-	-	-	-	-	-		-	-
	J	-	-	-	-	-	-	-	-	-		-
	K	-	-	-	-	-	-	-	-	-	-	

Phases in Stage

Stage No.	Phases in Stage
1	A D
2	C D
3	F G
4	B
5	E

Full Input Data And Results

Stage Diagram

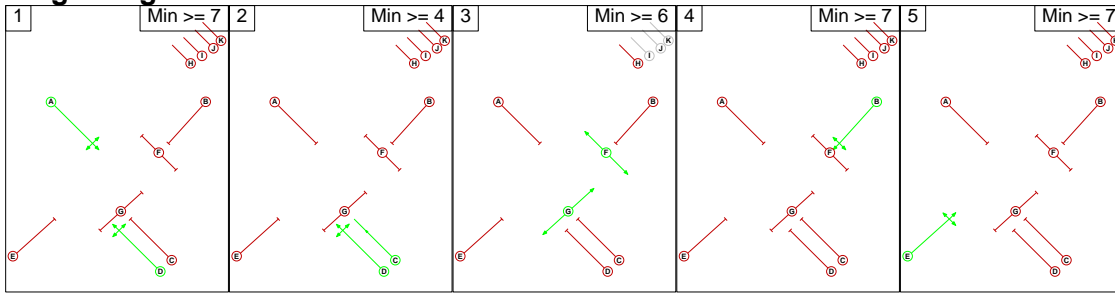

Phase Delays

Term. Stage	Start Stage	Phase	Type	Value	Cont value
There are no Phase Delays defined					

Prohibited Stage Change

		To Stage				
		1	2	3	4	5
From Stage	1		5	8	6	6
	2	6		8	5	6
	3	12	12		12	12
	4	5	5	7		6
	5	5	5	8	5	

C2 - B2068 Old Dover Road / Nackington Road - Canterbury. 06/060

Phase Diagram

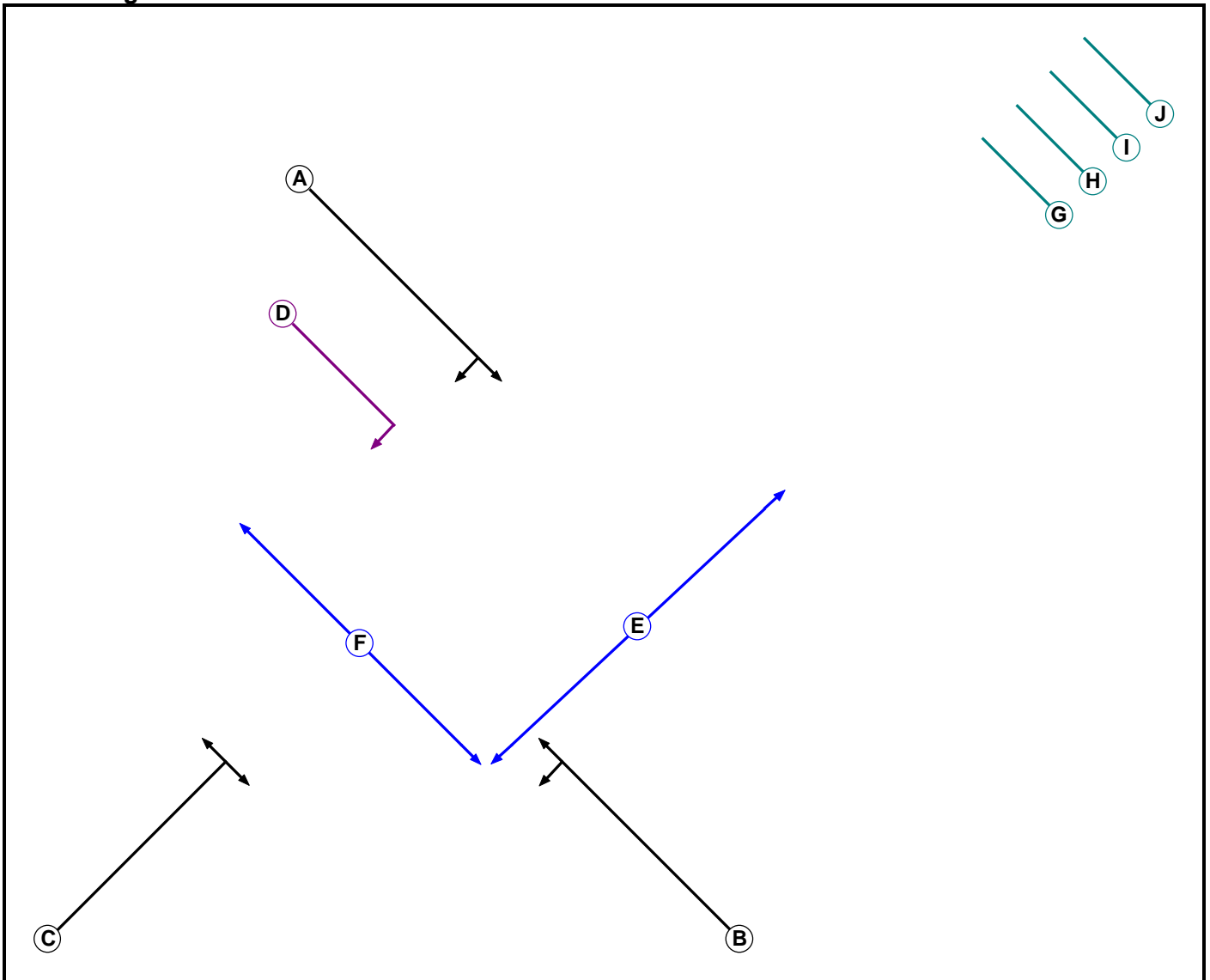

Phase Input Data

Phase Name	Phase Type	Assoc. Phase	Street Min	Cont Min
A	Traffic		-9999	7
B	Traffic		-9999	7
C	Traffic		-9999	7
D	Ind. Arrow	A	-9999	4
E	Pedestrian		-9999	6
F	Pedestrian		-9999	7
G	Dummy		-9999	1
H	Dummy		-9999	1
I	Dummy		-9999	6
J	Dummy		-9999	7

Full Input Data And Results

Phase Intergrens Matrix

		Starting Phase									
		A	B	C	D	E	F	G	H	I	J
Terminating Phase	A	-	-	7	-	9	9	3	9	9	9
	B	-	-	7	5	5	8	3	5	5	8
	C	5	5	-	5	9	5	3	5	9	5
	D	-	6	7	-	9	9	3	9	9	9
	E	9	9	9	9	-	-	4	-	-	-
	F	13	13	13	13	-	-	8	-	-	-
	G	0	0	0	0	0	0	-	0	-	-
	H	0	0	0	0	-	-	0	-	-	-
	I	-	-	-	-	-	-	-	-	-	-
	J	-	-	-	-	-	-	-	-	-	-

Phases in Stage

Stage No.	Phases in Stage
1	A B
2	A D
3	E F
4	C

Stage Diagram

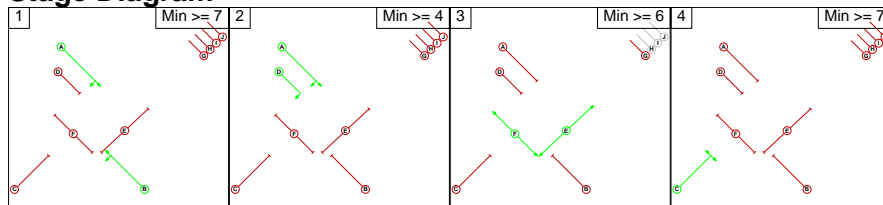

Phase Delays

Term. Stage	Start Stage	Phase	Type	Value	Cont value
There are no Phase Delays defined					

Prohibited Stage Change

		To Stage			
		1	2	3	4
From Stage	1	-	5	9	7
	2	6	-	9	7
	3	13	13	-	13
	4	5	5	9	-

Full Input Data And Results

Give-Way Lane Input Data

Junction: J1: St Lawrence Road/Old Dover Road											
Lane	Movement	Max Flow when Giving Way (PCU/Hr)	Min Flow when Giving Way (PCU/Hr)	Opposing Lane	Opp. Lane Coeff.	Opp. Mvmnts.	Right Turn Storage (PCU)	Non-Blocking Storage (PCU)	RTF	Right Turn Move up (s)	Max Turns in Intergreen (PCU)
J1:1/1 (Old Dover Road B2068 (WB))	J1:7/1 (Right)	1439	0	J1:3/1	1.09	To J1:7/1 (Left) To J2:3/1 (Ahead)	2.00	2.00	0.50	2	2.00
J1:3/1 (Old Dover Road)	J1:5/1 (Right)	1439	0	J1:1/1	1.09	To J1:5/1 (Left) To J1:6/1 (Ahead)	2.00	2.00	0.50	2	2.00

Junction: J2: Nackington Road/Old Dover Road Junction											
Lane	Movement	Max Flow when Giving Way (PCU/Hr)	Min Flow when Giving Way (PCU/Hr)	Opposing Lane	Opp. Lane Coeff.	Opp. Mvmnts.	Right Turn Storage (PCU)	Non-Blocking Storage (PCU)	RTF	Right Turn Move up (s)	Max Turns in Intergreen (PCU)
J2:3/2 (Old Dover Road B2068 (EB))	J2:5/1 (Right)	1439	0	J2:1/1	1.09	All	3.00	-	0.50	3	3.00

Full Input Data And Results

Lane Input Data

Junction: J1: St Lawrence Road/Old Dover Road												
Lane	Lane Type	Phases	Start Disp.	End Disp.	Physical Length (PCU)	Sat Flow Type	Def User Saturation Flow (PCU/Hr)	Lane Width (m)	Gradient	Nearside Lane	Turns	Turning Radius (m)
J1:1/1 (Old Dover Road B2068 (WB))	O	D	2	3	33.0	User	1840	-	-	-	-	-
J1:2/1 (The Drive)	U	E	2	3	60.0	User	1958	-	-	-	-	-
J1:3/1 (Old Dover Road)	O	A	2	3	60.0	User	1623	-	-	-	-	-
J1:4/1 (St Lawrence Road B2068)	U	B	2	3	60.0	User	1805	-	-	-	-	-
J1:5/1 (The Drive (Exit))	U		2	3	60.0	Inf	-	-	-	-	-	-
J1:6/1 (Old Dover Road (exit))	U		2	3	60.0	Inf	-	-	-	-	-	-
J1:7/1 (St Lawrence Road B2068 (Exit))	U		2	3	60.0	Inf	-	-	-	-	-	-

Junction: J2: Nackington Road/Old Dover Road Junction												
Lane	Lane Type	Phases	Start Disp.	End Disp.	Physical Length (PCU)	Sat Flow Type	Def User Saturation Flow (PCU/Hr)	Lane Width (m)	Gradient	Nearside Lane	Turns	Turning Radius (m)
J2:1/1 (Old Dover Road (WB))	U	B	2	3	60.0	User	2034	-	-	-	-	-
J2:2/1 (B2068 Nackington Road)	U	C	2	3	60.0	User	1743	-	-	-	-	-
J2:2/2 (B2068 Nackington Road)	U	C	2	3	3.0	User	1787	-	-	-	-	-
J2:3/1 (Old Dover Road B2068 (EB))	U	A	2	3	33.0	User	1915	-	-	-	-	-
J2:3/2 (Old Dover Road B2068 (EB))	O	A D	2	3	10.4	User	1787	-	-	-	-	-
J2:4/1 (Old Dover Road (EB Exit))	U		2	3	60.0	Inf	-	-	-	-	-	-
J2:5/1 (B2068 Nackington Road Exit)	U		2	3	60.0	Inf	-	-	-	-	-	-

Full Input Data And Results

Traffic Flow Groups

Flow Group	Start Time	End Time	Duration	Formula
1: 'AM Peak Hour 2014'	08:00	09:00	01:00	
2: 'PM Peak Hour 2014'	17:00	18:00	01:00	

Scenario 1: '2014 AM Peak Hour' (FG1: 'AM Peak Hour 2014', Plan 1: 'Network Control Plan 1')

Traffic Flows, Desired

Desired Flow :

	Destination						
		A	B	C	D	E	Tot.
Origin	A	0	40	102	26	122	290
	B	43	0	71	6	162	282
	C	102	102	0	16	316	536
	D	15	9	22	0	32	78
	E	53	70	180	25	0	328
	Tot.	213	221	375	73	632	1514

Traffic Lane Flows

Lane	Scenario 1: 2014 AM Peak Hour
Junction: J1: St Lawrence Road/Old Dover Road	
J1:1/1	645
J1:2/1	78
J1:3/1	328
J1:4/1	290
J1:5/1	73
J1:6/1	632
J1:7/1	213
Junction: J2: Nackington Road/Old Dover Road Junction	
J2:1/1	282
J2:2/1 (with short)	536(In) 434(Out)
J2:2/2 (short)	102
J2:3/1 (with short)	423(In) 119(Out)
J2:3/2 (short)	304
J2:4/1	221
J2:5/1	375

Full Input Data And Results

Lane Saturation Flows

Junction: J1: St Lawrence Road/Old Dover Road								
Lane	Lane Width (m)	Gradient	Nearside Lane	Allowed Turns	Turning Radius (m)	Turning Prop.	Sat Flow (PCU/Hr)	Flared Sat Flow (PCU/Hr)
J1:1/1 (Old Dover Road B2068 (WB) Lane 1)							1840	1840
J1:2/1 (The Drive Lane 1)							1958	1958
J1:3/1 (Old Dover Road Lane 1)							1623	1623
J1:4/1 (St Lawrence Road B2068 Lane 1)							1805	1805
J1:5/1 (The Drive (Exit) Lane 1)							Inf	Inf
J1:6/1 (Old Dover Road (exit) Lane 1)							Inf	Inf
J1:7/1 (St Lawrence Road B2068 (Exit) Lane 1)							Inf	Inf

Junction: J2: Nackington Road/Old Dover Road Junction								
Lane	Lane Width (m)	Gradient	Nearside Lane	Allowed Turns	Turning Radius (m)	Turning Prop.	Sat Flow (PCU/Hr)	Flared Sat Flow (PCU/Hr)
J2:1/1 (Old Dover Road (WB) Lane 1)							2034	2034
J2:2/1 (B2068 Nackington Road Lane 1)							1743	1743
J2:2/2 (B2068 Nackington Road Lane 2)							1787	1787
J2:3/1 (Old Dover Road B2068 (EB) Lane 1)							1915	1915
J2:3/2 (Old Dover Road B2068 (EB) Lane 2)							1787	1787
J2:4/1 (Old Dover Road (EB Exit) Lane 1)							Inf	Inf
J2:5/1 (B2068 Nackington Road Exit Lane 1)							Inf	Inf

Full Input Data And Results

Scenario 2: '2014 PM Peak Hour' (FG2: 'PM Peak Hour 2014', Plan 1: 'Network Control Plan 1')

Traffic Flows, Desired

Desired Flow :

	Destination						
		A	B	C	D	E	Tot.
Origin	A	0	62	104	14	25	205
	B	36	0	105	20	92	253
	C	56	100	0	33	134	323
	D	34	21	33	0	40	128
	E	68	155	271	46	0	540
	Tot.	194	338	513	113	291	1449

Traffic Lane Flows

Lane	Scenario 2: 2014 PM Peak Hour
Junction: J1: St Lawrence Road/Old Dover Road	
J1:1/1	371
J1:2/1	128
J1:3/1	540
J1:4/1	205
J1:5/1	113
J1:6/1	291
J1:7/1	194
Junction: J2: Nackington Road/Old Dover Road Junction	
J2:1/1	253
J2:2/1 (with short)	323(In) 223(Out)
J2:2/2 (short)	100
J2:3/1 (with short)	646(In) 238(Out)
J2:3/2 (short)	408
J2:4/1	338
J2:5/1	513

Lane Saturation Flows

Junction: J1: St Lawrence Road/Old Dover Road								
Lane	Lane Width (m)	Gradient	Nearside Lane	Allowed Turns	Turning Radius (m)	Turning Prop.	Sat Flow (PCU/Hr)	Flared Sat Flow (PCU/Hr)
J1:1/1 (Old Dover Road B2068 (WB) Lane 1)							1840	1840
J1:2/1 (The Drive Lane 1)							1958	1958
J1:3/1 (Old Dover Road Lane 1)							1623	1623
J1:4/1 (St Lawrence Road B2068 Lane 1)							1805	1805
J1:5/1 (The Drive (Exit) Lane 1)							Inf	Inf
J1:6/1 (Old Dover Road (exit) Lane 1)							Inf	Inf
J1:7/1 (St Lawrence Road B2068 (Exit) Lane 1)							Inf	Inf

Junction: J2: Nackington Road/Old Dover Road Junction								
Lane	Lane Width (m)	Gradient	Nearside Lane	Allowed Turns	Turning Radius (m)	Turning Prop.	Sat Flow (PCU/Hr)	Flared Sat Flow (PCU/Hr)
J2:1/1 (Old Dover Road (WB) Lane 1)							2034	2034
J2:2/1 (B2068 Nackington Road Lane 1)							1743	1743
J2:2/2 (B2068 Nackington Road Lane 2)							1787	1787
J2:3/1 (Old Dover Road B2068 (EB) Lane 1)							1915	1915
J2:3/2 (Old Dover Road B2068 (EB) Lane 2)							1787	1787
J2:4/1 (Old Dover Road (EB Exit) Lane 1)							Inf	Inf
J2:5/1 (B2068 Nackington Road Exit Lane 1)							Inf	Inf

Scenario 1: '2014 AM Peak Hour' (FG1: 'AM Peak Hour 2014', Plan 1: 'Network Control Plan 1')
C1 - B2068 Old Dover / St Lawrence Rd, Canterbury. 06/0

Stage Sequence Diagram

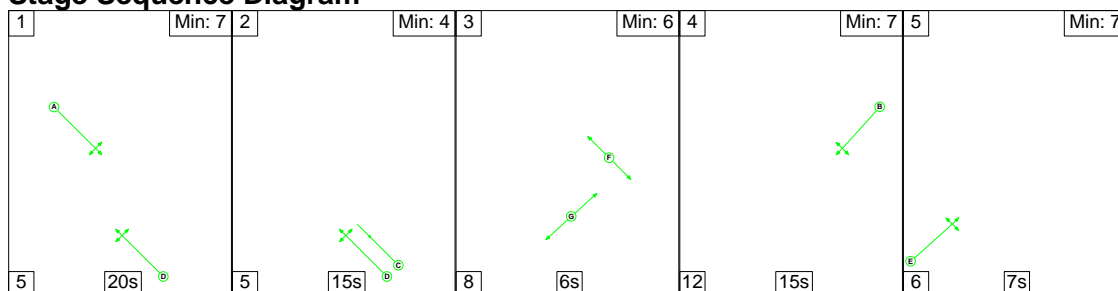

Stage Timings

Stage	1	2	3	4	5
Duration	20	15	6	15	7
Change Point	0	25	45	59	86

Signal Timings Diagram

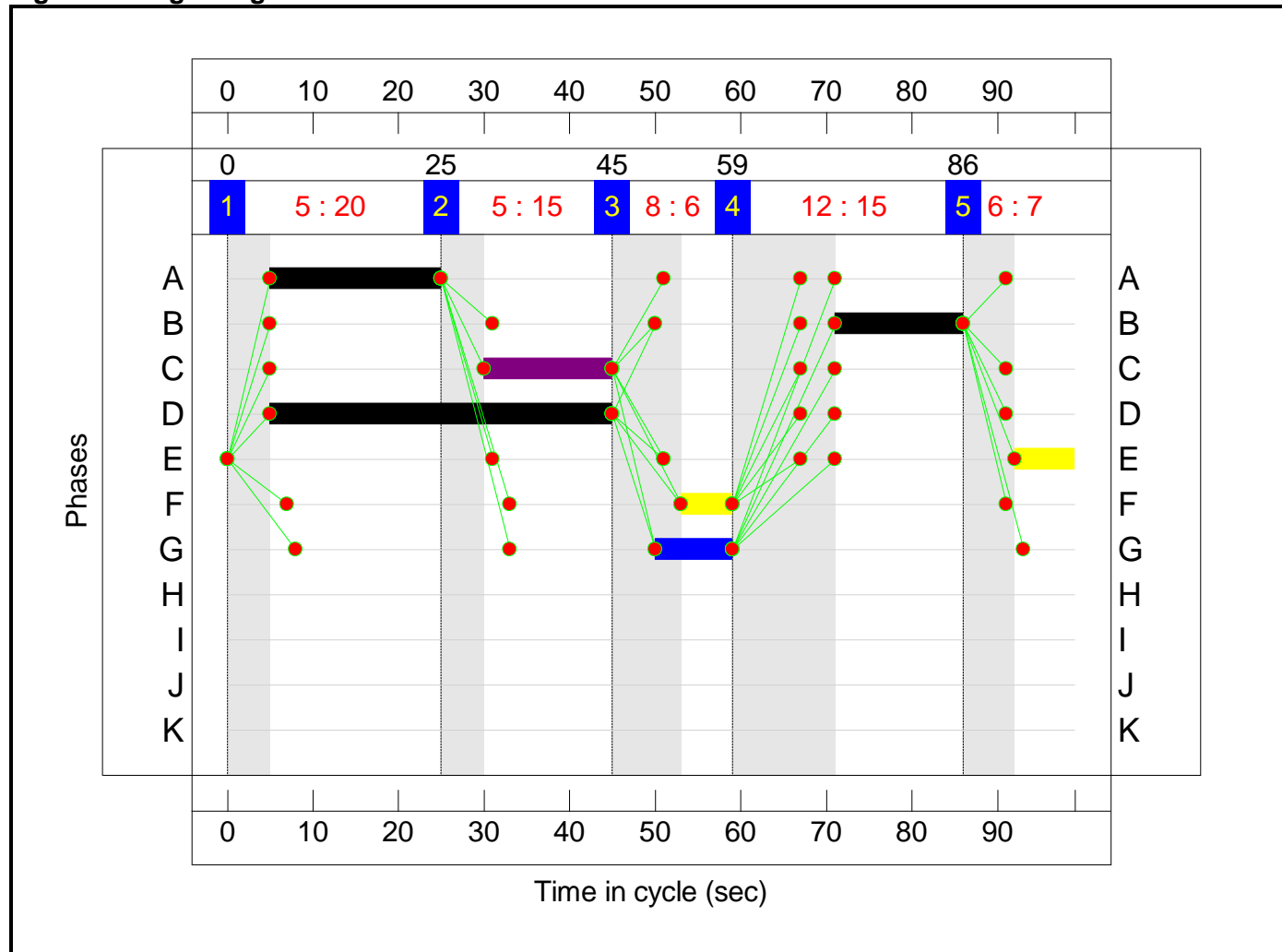

C2 - B2068 Old Dover Road / Nackington Road - Canterbury. 06/060

Stage Sequence Diagram

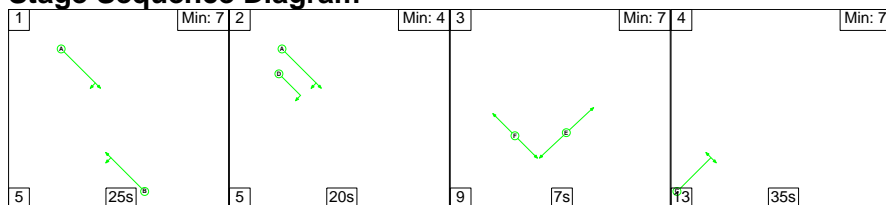

Stage Timings

Stage	1	2	3	4
Duration	25	20	7	35
Change Point	0	30	55	71

Signal Timings Diagram

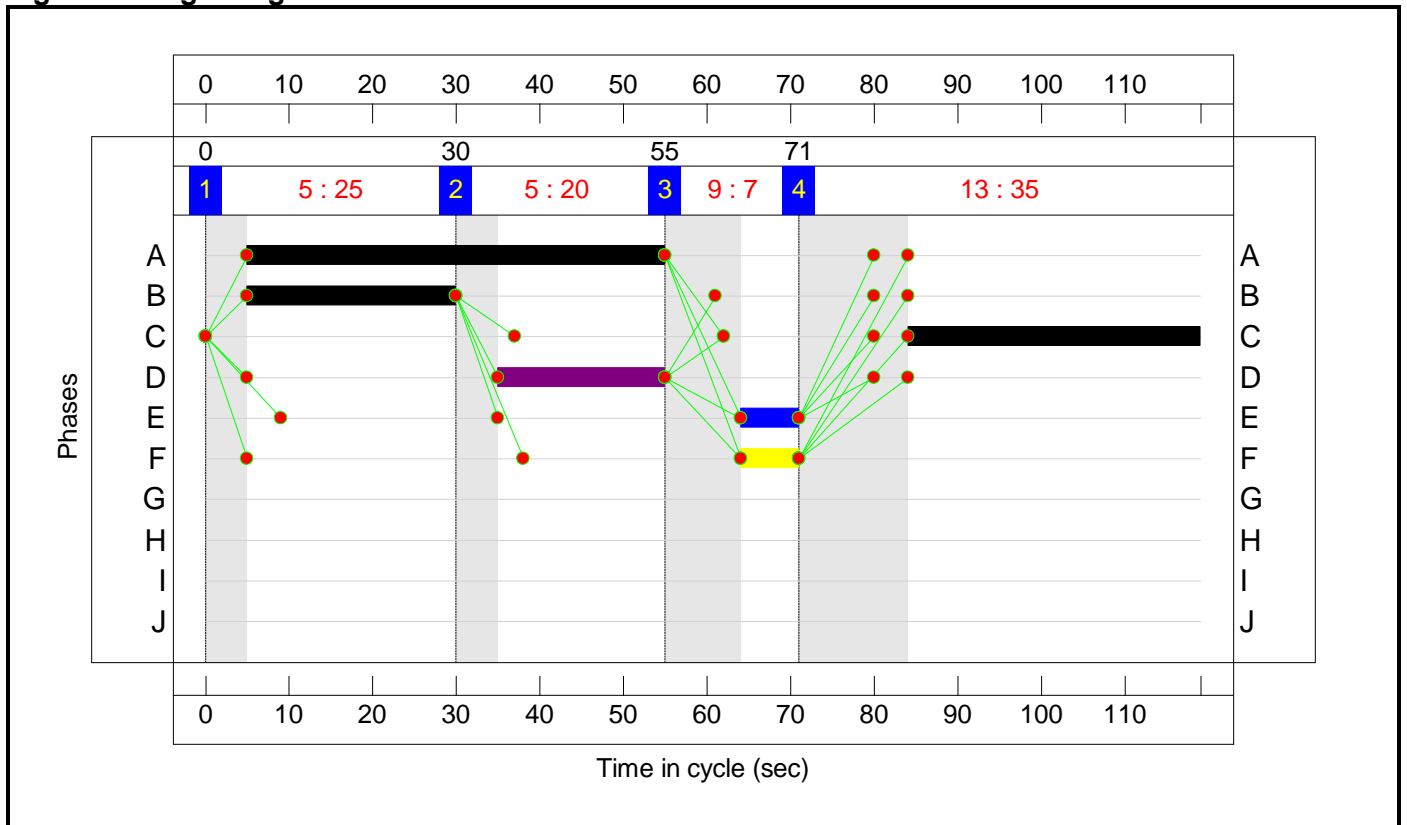

Full Input Data And Results
Network Layout Diagram

Full Input Data And Results

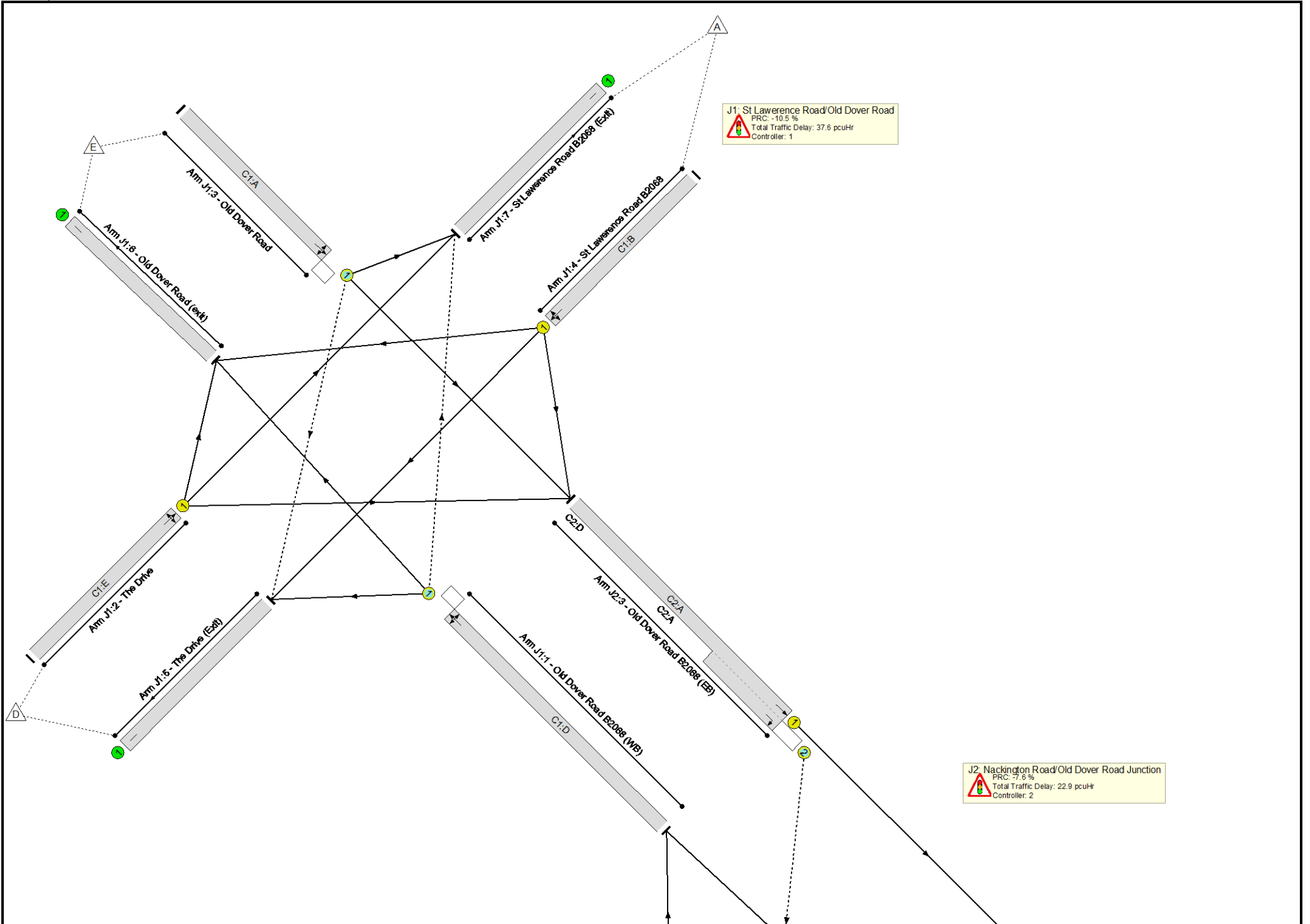

Full Input Data And Results

Full Input Data And Results

Network Results

Item	Lane Description	Lane Type	Controller Stream	Position In Filtered Route	Full Phase	Arrow Phase	Num Greens	Total Green (s)	Arrow Green (s)	Demand Flow (pcu)	Sat Flow (pcu/Hr)	Capacity (pcu)	Deg Sat (%)
Network	-	-	N/A	-	-		-	-	-	-	-	-	99.4%
J1: St Lawrence Road/Old Dover Road	-	-	N/A	-	-		-	-	-	-	-	-	99.4%
1/1	Old Dover Road B2068 (WB) Left Ahead Right	O	N/A	N/A	C1:D		1	40	-	645	1840	658	98.0%
2/1	The Drive Left Ahead Right	U	N/A	N/A	C1:E		1	7	-	78	1958	158	49.3%
3/1	Old Dover Road Right Left Ahead	O	N/A	N/A	C1:A		1	20	-	328	1623	344	95.3%
4/1	St Lawrence Road B2068 Ahead Right Left	U	N/A	N/A	C1:B		1	15	-	290	1805	292	99.4%
5/1	The Drive (Exit)	U	N/A	N/A	-		-	-	-	73	Inf	Inf	0.0%
6/1	Old Dover Road (exit)	U	N/A	N/A	-		-	-	-	632	Inf	Inf	0.0%
7/1	St Lawrence Road B2068 (Exit)	U	N/A	N/A	-		-	-	-	213	Inf	Inf	0.0%
J2: Nackington Road/Old Dover Road Junction	-	-	N/A	-	-		-	-	-	-	-	-	96.8%
1/1	Old Dover Road (WB) Ahead Left	U	N/A	N/A	C2:B		1	25	-	282	2034	444	63.5%
2/1+2/2	B2068 Nackington Road Left Right	U	N/A	N/A	C2:C		1	35	-	536	1743:1787	448+105	96.8 : 96.8%
3/1+3/2	Old Dover Road B2068 (EB) Ahead Right	U+O	N/A	N/A	C2:A	C2:D	1	50	20	423	1915:1787	185+473	64.2 : 64.2%
4/1	Old Dover Road (EB Exit)	U	N/A	N/A	-		-	-	-	221	Inf	Inf	0.0%
5/1	B2068 Nackington Road Exit	U	N/A	N/A	-		-	-	-	375	Inf	Inf	0.0%

Full Input Data And Results

Scenario 2: '2014 PM Peak Hour' (FG2: 'PM Peak Hour 2014', Plan 1: 'Network Control Plan 1')

C1 - B2068 Old Dover / St Lawrence Rd, Canterbury. 06/0

Stage Sequence Diagram

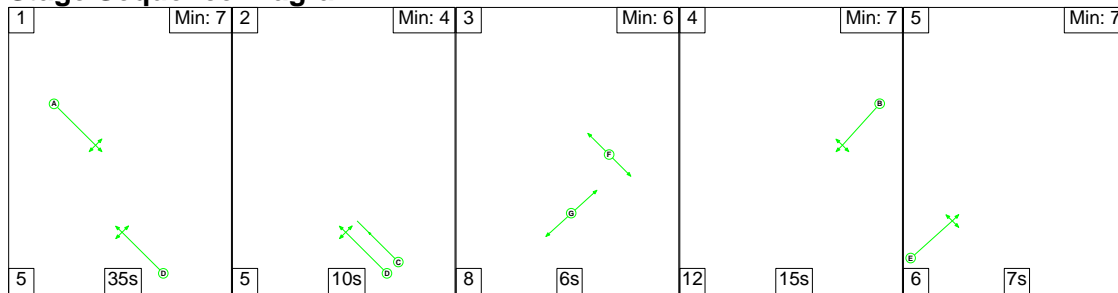

Stage Timings

Stage	1	2	3	4	5
Duration	35	10	6	15	7
Change Point	0	40	55	69	96

Signal Timings Diagram

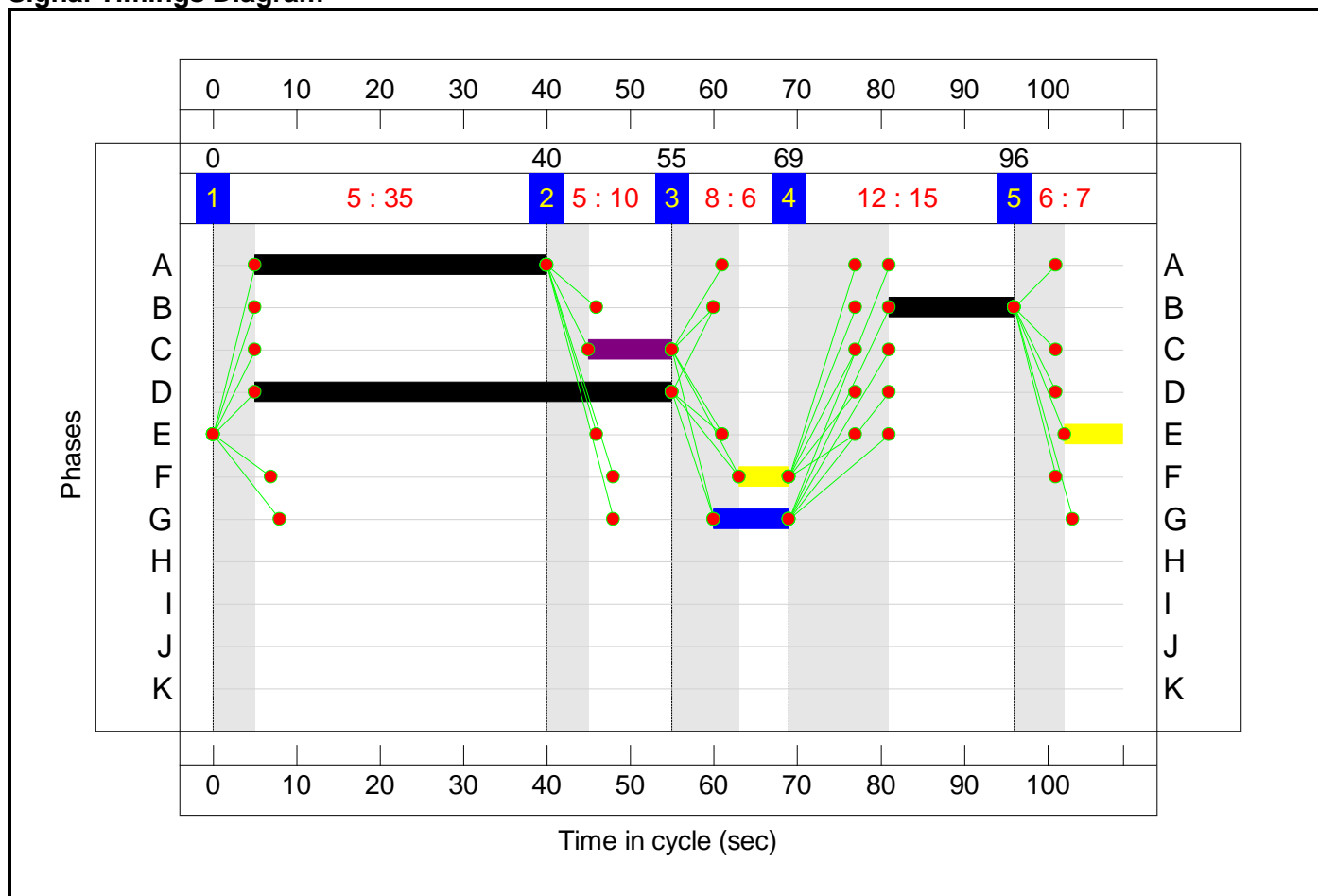

C2 - B2068 Old Dover Road / Nackington Road - Canterbury. 06/060

Stage Sequence Diagram

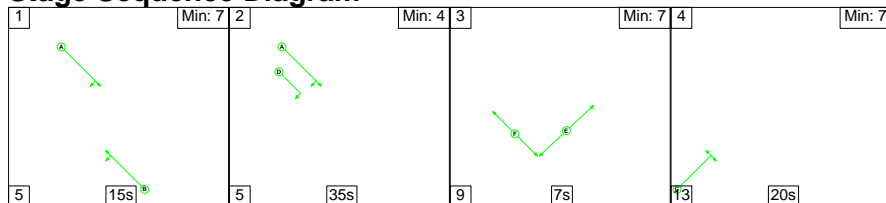

Full Input Data And Results

Stage Timings

Stage	1	2	3	4
Duration	15	35	7	20
Change Point	2	22	62	78

Signal Timings Diagram

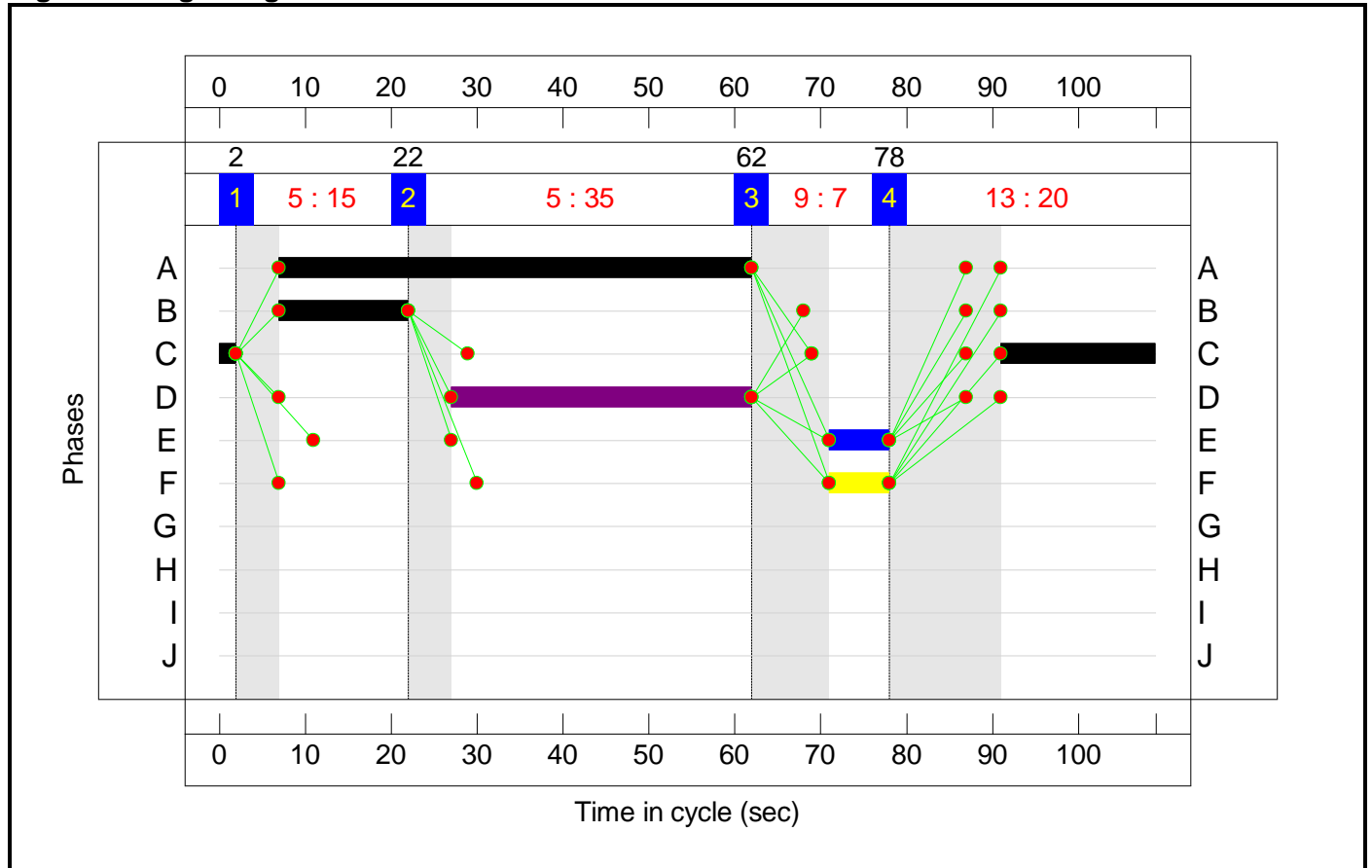

Full Input Data And Results
Network Layout Diagram

Full Input Data And Results

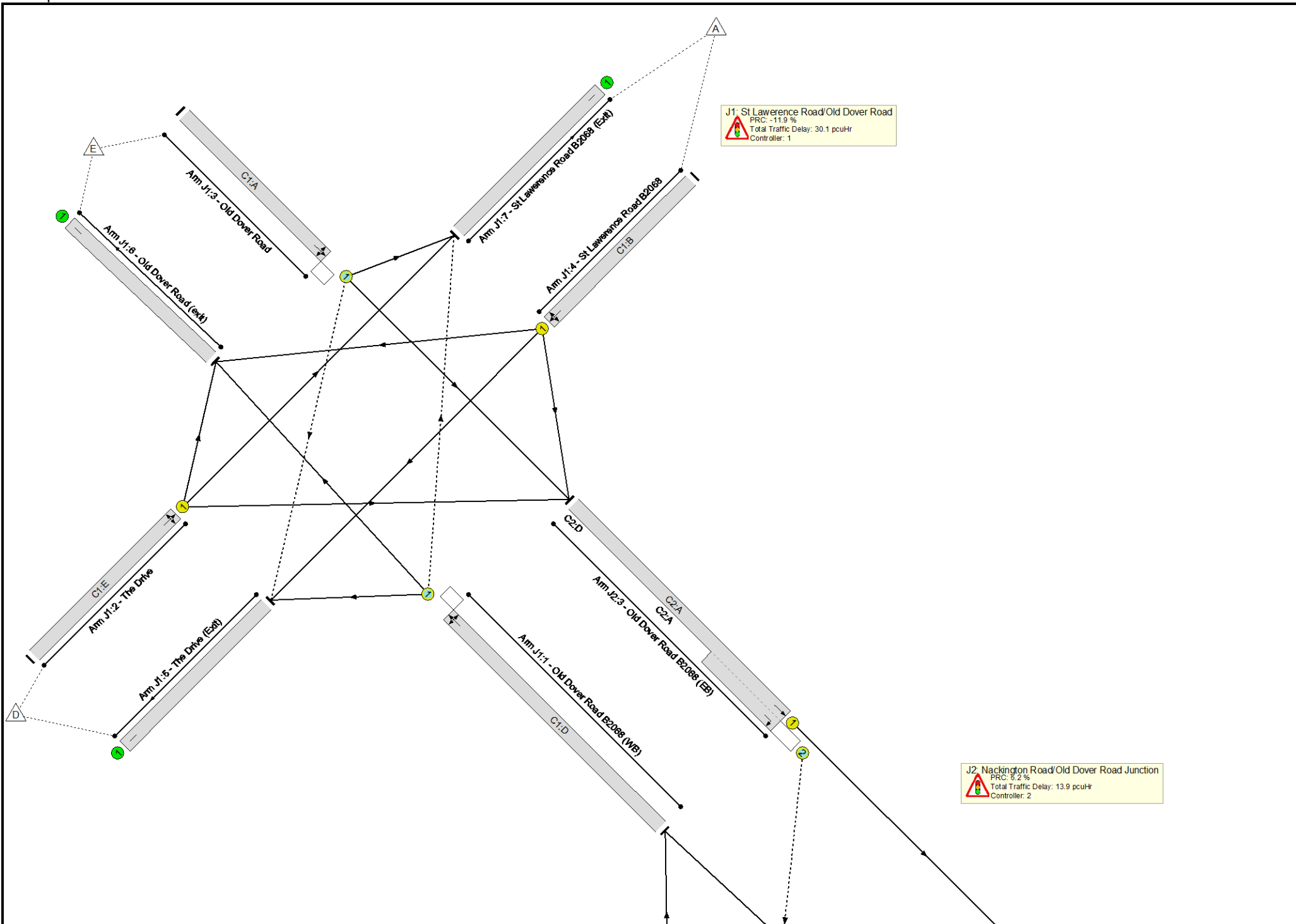

Full Input Data And Results

Full Input Data And Results

Network Results

Item	Lane Description	Lane Type	Controller Stream	Position In Filtered Route	Full Phase	Arrow Phase	Num Greens	Total Green (s)	Arrow Green (s)	Demand Flow (pcu)	Sat Flow (pcu/Hr)	Capacity (pcu)	Deg Sat (%)
Network	-	-	N/A	-	-		-	-	-	-	-	-	100.7%
J1: St Lawrence Road/Old Dover Road	-	-	N/A	-	-		-	-	-	-	-	-	100.7%
1/1	Old Dover Road B2068 (WB) Left Ahead Right	O	N/A	N/A	C1:D		1	50	-	371	1840	452	82.1%
2/1	The Drive Left Ahead Right	U	N/A	N/A	C1:E		1	7	-	128	1958	144	89.1%
3/1	Old Dover Road Right Left Ahead	O	N/A	N/A	C1:A		1	35	-	540	1623	536	100.7%
4/1	St Lawrence Road B2068 Ahead Right Left	U	N/A	N/A	C1:B		1	15	-	205	1805	265	77.4%
5/1	The Drive (Exit)	U	N/A	N/A	-		-	-	-	113	Inf	Inf	0.0%
6/1	Old Dover Road (exit)	U	N/A	N/A	-		-	-	-	291	Inf	Inf	0.0%
7/1	St Lawrence Road B2068 (Exit)	U	N/A	N/A	-		-	-	-	194	Inf	Inf	0.0%
J2: Nackington Road/Old Dover Road Junction	-	-	N/A	-	-		-	-	-	-	-	-	84.7%
1/1	Old Dover Road (WB) Ahead Left	U	N/A	N/A	C2:B		1	15	-	253	2034	299	84.7%
2/1+2/2	B2068 Nackington Road Left Right	U	N/A	N/A	C2:C		1	20	-	323	1743:1787	266+119	83.8 : 83.8%
3/1+3/2	Old Dover Road B2068 (EB) Ahead Right	U+O	N/A	N/A	C2:A	C2:D	1	55	35	646	1915:1787	367+629	64.6 : 64.5%
4/1	Old Dover Road (EB Exit)	U	N/A	N/A	-		-	-	-	338	Inf	Inf	0.0%
5/1	B2068 Nackington Road Exit	U	N/A	N/A	-		-	-	-	513	Inf	Inf	0.0%

Arcadis UK

34 York Way
London N1 9AB

T: +44 (0) 20 7812 2000

[arcadis.com](https://www.arcadis.com)



APPENDIX C – Survey Data Validation Report (Folkstone & Hythe and Ashford)

OTTERPOOL PARK

Traffic Survey Data Analysis

MARCH 2018

Incorporating

EC HARRIS
BUILT ASSET
CONSULTANCY



CONTENTS

1	INTRODUCTION	1
1.1	Background.....	1
1.2	Structure of this Note.....	1
2	CLASSIFIED TURNING COUNT DATA.....	2
2.1	Data to be Used for Assessment	2
2.2	Peak Period Analysis	4
2.3	Analysis of Flow Volumes through Adjacent Junctions	5
2.3.1	Differences between In/Out Flows of Adjacent Junctions	5
2.3.2	Traffic Flow Difference Analysis and Recommendations	8
2.4	Comparison of 2013, 2016 and 2017 survey data in adjacent junctions.....	22
2.5	Forecast Traffic Flows for Future Case Modelling.....	24
3	ORIGIN-DESTINATION (OD) SURVEYS.....	25
4	CONCLUSION.....	27

FIGURES

Figure 1	Classified Turning counts locations.....	2
Figure 2	Classified turning counts peak period analysis.	5

TABLES

Table 1.	Summary of traffic counts.....	2
Table 2.	Classified turning counts list.....	3
Table 3	Summary of classified turning counts by category.	4
Table 4	AM Peak (8-9am) Traffic flow differences for adjacent surveyed junctions.	5
Table 5	PM Peak (5-6pm) Traffic flow differences for adjacent surveyed junctions.	6
Table 6	Traffic flow difference between adjacent junctions surveyed in different years.	22
Table 7.	Registered percentage of vehicles in the ANPR	26

APPENDICES

APPENDIX A

ANPR Camera locations

APPENDIX B

Classified Turning Counts (Summary)

1 Introduction

1.1 Background

Arcadis was appointed in August 2016 to develop a masterplan and planning application in respect of the proposed garden settlement called Otterpool Park.

The scope of Transport work required for the application is being discussed with Kent County Council, Folkstone & Hythe District Council and Highways England. Traffic modelling has been requested to assess the performance of the network and determine the effect of the Otterpool Park development proposals, for which traffic survey data in the form of classified turning counts and origin-destination data is required. Some of the required traffic survey data was collected by Folkstone & Hythe District Council on Tuesday 22nd October 2013 and Thursday 13th October 2016 and this data has been made available to Arcadis for use on the Otterpool Park assessment. The remainder of the data required for the study was collected on 29th June 2017. This report has been produced to check the quality of the data collected in 2017 and to validate the flow volumes against the 2016 data.

1.2 Structure of this Note

The remainder of this Note is structured as follows:

- Section 2** **Classified Turning Counts**
- Section 3** **Origin-Destination Data**
- Section 4** **Conclusion**

2 Classified Turning Count Data

2.1 Data to be Used for Assessment

Table 1 summarises the traffic count data intended for use in the Otterpool Park traffic modelling.

Table 1. Summary of traffic counts

Data set	Dates	Locations	Details
Classified turning counts	29 th June 2017	19 sites within the study area	Fully classified turning counts, summarised in 15 minutes time intervals.
Classified turning counts	13 th October 2016	14 sites within the study area	Fully classified turning counts, summarised in 15 minutes time intervals.
TRADS	Extracted from database for June 2017 or October 2016	A number of sites on the M20	Highways England administered online database of counts collected using permanent traffic counters. Counts are available by time period and basic vehicle classification estimated by vehicle length.

Figure 1 shows the locations at which the Classified Turning Counts were undertaken and Table 2 provides a full list of these locations.

Figure 1 Classified Turning counts locations

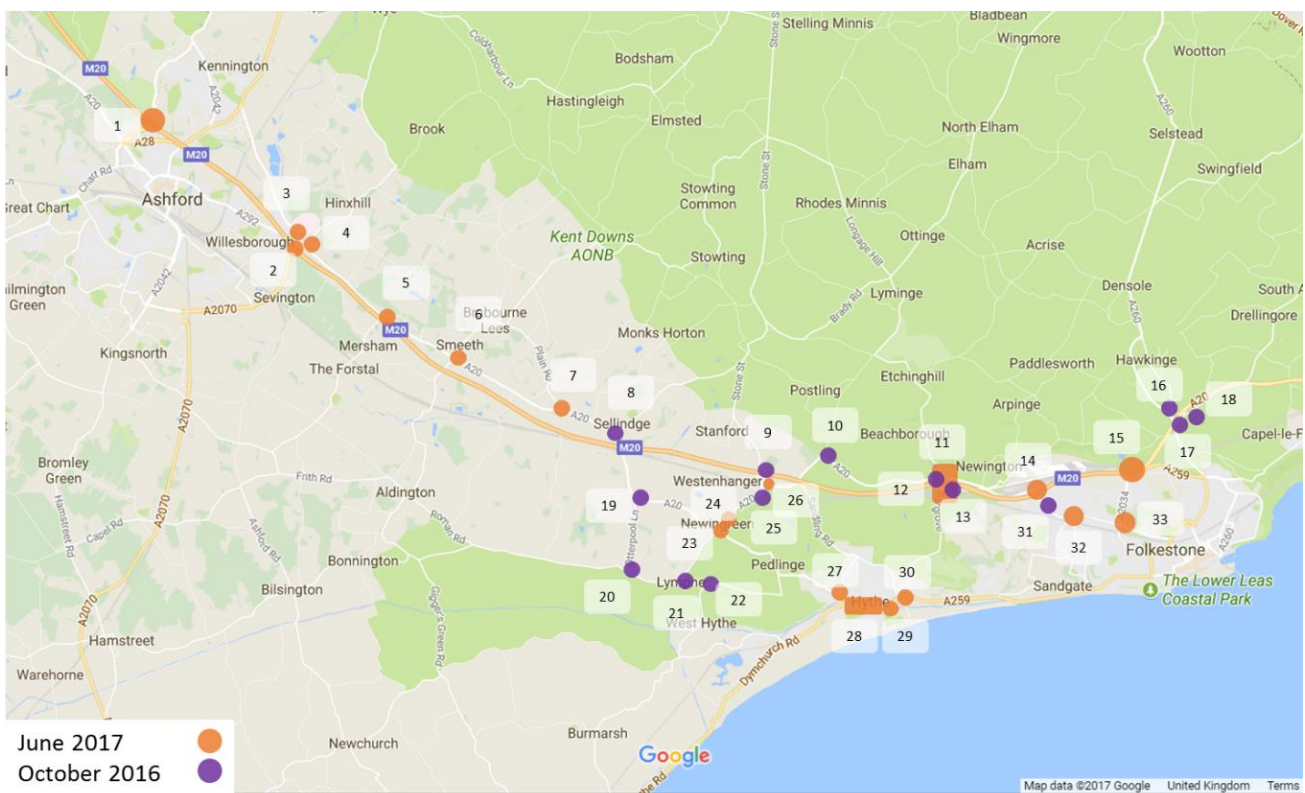

Otterpool Park
Traffic Survey Data Analysis

Table 2. Classified turning counts list

Site ID	Survey date	Location
1	29/06/2017	M20 J9- signalised full OD including all on/ offslips and M20 overpass
2	29/06/2017	M20 J10- signalised roundabout- full OD (including underpass)
3	29/06/2017	Hythe Road (A20)/ The Street (West)- priority- turning counts
4	29/06/2017	Hythe Road (A20)/ The Street (East)- priority- turning counts
5	29/06/2017	Hythe Road (A20)/ Mersham- priority- turning counts
6	29/06/2017	Ashford Road (A20)/ Station Road/ Church Road- priority- turning counts
7	29/06/2017	Ashford Road (A20)/ Stone Hill- priority- turning count
8	13/10/2016	Ashford Road (A20)/ Swan Lane- priority- turning counts
9	13/10/2016	M20 J11- non-signalised roundabout- full OD (including overpass)
10	13/10/2016	Ashford Road/ Sandling Road- priority- turning counts
11	29/06/2017	M20 J11A- priority full OD required including all on/ offslips and M20 underpass
12	13/10/2016	Eurotunnel entry
13	13/10/2016	Eurotunnel exit
14	29/06/2017	M20 J12- priority full OD required including all on/ offslips and M20 overpass
15	29/06/2017	M20 J13- priority full OD required including all on/ offslips and M20 overpass
16	13/10/2016	White Horse Hill / A20 EB slips / A260 / A260 Spitfire Way
17	13/10/2016	A20 WB slips / Alkham Valley Road
18	13/10/2016	A260 Canterbury Road / Alkham Valley Road
19	13/10/2016	A20 Ashford Road/ B2067 Otterpool Lane- signalised junction- turning counts
20	13/10/2016	B2067 Otterpool Lane/ Aldington Road- priority- turning counts
21	13/10/2016	Aldington Road/ Stone Street- priority- turning counts
22	13/10/2016	Aldington Road/ Lypne Hill- priority- turning counts
23	29/06/2017	A20 Ashford Road/ A261 Hythe Road/Stone Street- priority- turning counts
24	29/06/2017	A20 Ashford Road/ Stone Street- priority- turning counts
25	13/10/2016	A20 Ashford Road roundabout
26	29/06/2017	A20 Ashford Road/ A20 J11 offslip- priority- turning counts
27	29/06/2017	A261 London Road/ Barrack Hill- priority- turning counts
28	29/06/2017	A259/ Dymchurch Road/ Military Road gyratory- signalised- full OD
29	29/06/2017	A259 Prospect Road / Stade Street – priority – turning counts
30	29/06/2017	A259 Prospect Road/ A259 Seabrook Road/ Station Road/ High Street- priority roundabout- full OD
31	22/10/2013	A20 Cheriton Interchange / B2064 Cheriton High Street
32	29/06/2017	B2064 Cheriton High street / B2063 Risborough Lane – priority – turning counts
33	29/06/2017	B2064 Cheriton High street / A2034 Cherry Garden avenue – priority – turning counts

2.2 Peak Period Analysis

A peak period analysis was carried out by combining counts for all the sites where classified turning counts were collected then producing total hourly flows (sum of the preceding four 15-minute periods). Table 3 and Figure 2 show the results of these calculations. The table and figure show that the AM and PM peak flow hours were observed to be 08:00-09:00, with a total flow of 60,428 vehicles/hour, and 17:00-18:00, with a total flow of 62,521 vehicles/hour, respectively.

Table 3 Summary of classified turning counts by category.

PERIOD	Time (Hour beginning)	HOURLY FLOWS										
		Car	Taxi	LGV	OGV 1	OGV 2	Bus	Coach	MCY	PCY	TOTAL	Only motorised
AM	07:00	35,628	4	7,507	948	1,149	279	365	326	109	46,315	46,206
	07:15	41,688	4	7,855	1,007	1,103	309	400	316	103	52,785	52,682
	07:30	46,670	4	7,695	1,124	1,092	300	398	317	90	57,690	57,600
	07:45	49,727	4	7,325	1,239	1,071	259	398	296	68	60,387	60,319
	08:00	50,382	8	6,728	1,298	1,061	247	419	285	71	60,499	60,428
	08:15	47,750	16	6,376	1,341	1,091	220	405	274	61	57,534	57,473
	08:30	43,788	19	6,134	1,349	1,196	243	404	236	69	53,438	53,369
	08:45	38,681	23	5,933	1,285	1,174	228	388	242	74	48,028	47,954
	09:00	34,639	22	5,803	1,333	1,196	234	385	222	111	43,945	43,834
PM	16:00	45,692	9	7,390	842	972	229	383	460	80	56,057	55,977
	16:15	48,534	7	7,215	781	958	224	361	483	92	58,655	58,563
	16:30	51,190	5	6,912	654	889	216	330	482	102	60,780	60,678
	16:45	53,046	1	6,442	546	888	227	295	495	109	62,049	61,940
	17:00	54,260	2	5,861	497	862	232	278	529	125	62,646	62,521
	17:15	51,968	2	5,131	464	827	220	282	507	134	59,535	59,401
	17:30	48,408	2	4,467	457	858	222	280	437	139	55,270	55,131
	17:45	43,992	1	3,825	420	829	205	270	405	142	50,089	49,947
	18:00	39,956	-	3,298	377	796	171	233	391	134	45,356	45,222

Figure 2 Classified turning counts peak period analysis.

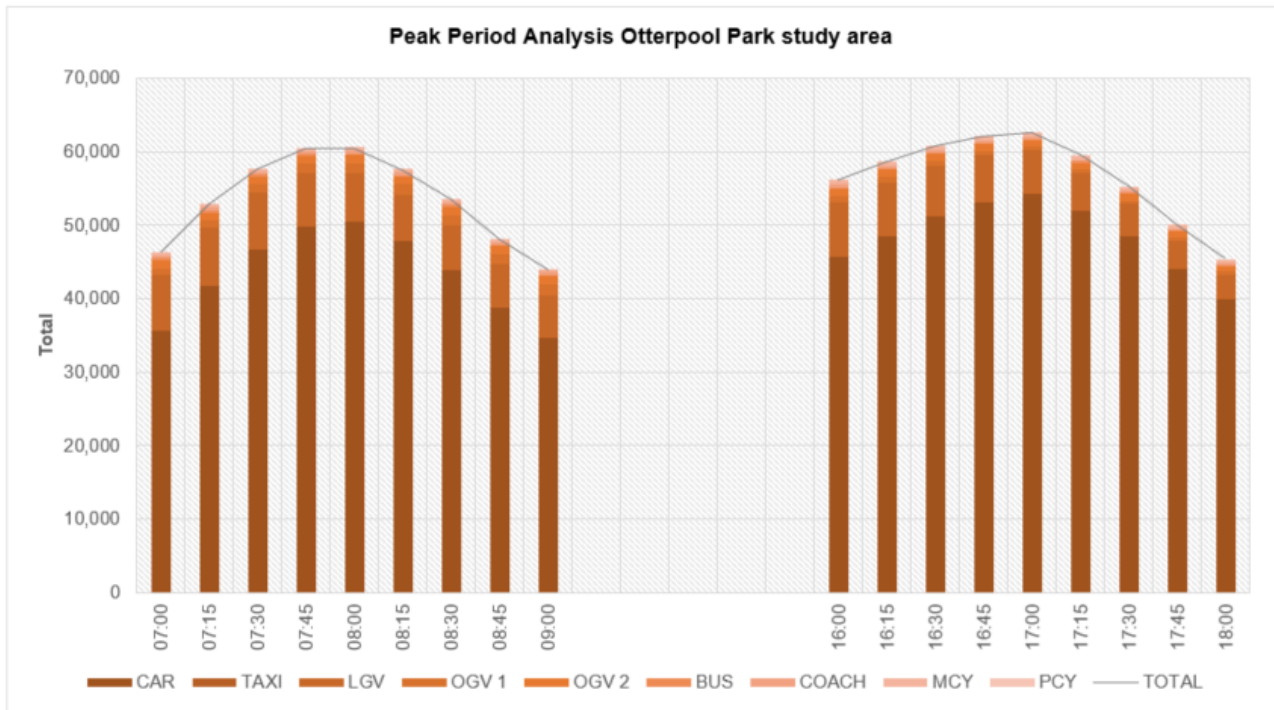

2.3 Analysis of Flow Volumes through Adjacent Junctions

2.3.1 Differences between In/Out Flows of Adjacent Junctions

A comparison of traffic flow volumes through adjacent junctions was carried out among the locations previously presented in Figure 1. The flow into the two junctions in each direction has been compared to the flow out of the junctions. Variances in flows were to be expected due to the date difference among some of the surveys and results are presented in Table 4 and Table 5.

Table 4 AM Peak (8-9am) Traffic flow differences for adjacent surveyed junctions.

2-3	WB	EB
IN	797	420
OUT	798	435
Diff	0%	4%

23-24	NB	SB
IN	723	647
OUT	724	646
Diff	0%	0%

22-21	EB	WB
IN	189	272
OUT	182	310
Diff	-4%	14%

2-4	WB	EB
IN	876	695
OUT	876	660
Diff	0%	-5%

11-14	NB	SB
IN	605	541
OUT	412	606
Diff	-32%	12%

10-11	EB	WB
IN	139	101
OUT	101	91
Diff	-27%	-10%

4-5	WB	EB
IN	611	548
OUT	627	522
Diff	3%	-5%

32-33	WB	EB
IN	332	537
OUT	474	562
Diff	43%	5%

14-31	EB	WB
IN	1126	927
OUT	1135	1117
Diff	1%	20%

Otterpool Park
Traffic Survey Data Analysis

6-5	WB	EB
IN	408	449
OUT	528	380
Diff	29%	-15%

8-7	EB	WB
IN	284	397
OUT	290	374
Diff	2%	-6%

32-31	EB	WB
IN	568	580
OUT	477	637
Diff	-16%	10%

6-7	WB	EB
IN	319	239
OUT	297	209
Diff	-7%	-13%

8-19	EB	WB
IN	258	266
OUT	254	314
Diff	-2%	18%

26-9	NB	SB
IN	975	826
OUT	928	869
Diff	-5%	5%

28-27	WB	EB
IN	584	537
OUT	573	517
Diff	-2%	-4%

20-19	SB	NB
IN	245	190
OUT	98	196
Diff	-60%	3%

24-25	NB	SB
IN	727	713
OUT	728	662
Diff	0%	-7%

28-29	WB	EB
IN	434	901
OUT	425	891
Diff	-2%	-1%

20-21	EB	WB
IN	92	183
OUT	80	136
Diff	-13%	-26%

26-25	NB	SB
IN	980	920
OUT	975	964
Diff	-1%	5%

30-29	WB	EB
IN	565	826
OUT	522	785
Diff	-8%	-5%

23-21	NB	SB
IN	175	141
OUT	288	157
Diff	65%	11%

Table 5 PM Peak (5-6pm) Traffic flow differences for adjacent surveyed junctions.

2-3	WB	EB
IN	472	647
OUT	457	647
Diff	-3%	0%

23-24	NB	SB
IN	693	766
OUT	693	766
Diff	0%	0%

22-21	EB	WB
IN	331	122
OUT	309	137
Diff	-7%	12%

2-4	WB	EB
IN	827	823
OUT	824	844
Diff	0%	3%

11-14	NB	SB
IN	502	411
OUT	471	624
Diff	-6%	52%

10-11	EB	WB
IN	88	72
OUT	75	64
Diff	-15%	-11%

4-5	WB	EB
IN	486	698
OUT	504	654
Diff	4%	-6%

32-33	WB	EB
IN	351	685
OUT	533	617
Diff	52%	-10%

14-31	EB	WB
IN	1358	1083
OUT	1208	1135
Diff	-11%	5%

6-5	WB	EB
IN	371	577
OUT	445	526
Diff	20%	-9%

8-7	EB	WB
IN	431	283
OUT	412	315
Diff	-4%	11%

32-31	EB	WB
IN	746	663
OUT	685	618
Diff	-8%	-7%

Otterpool Park
Traffic Survey Data Analysis

6-7	WB	EB
IN	268	372
OUT	294	391
Diff	10%	5%

8-19	EB	WB
IN	313	258
OUT	271	271
Diff	-13%	5%

26-9	NB	SB
IN	846	986
OUT	744	1020
Diff	-12%	3%

28-27	WB	EB
IN	460	658
OUT	453	636
Diff	-2%	-3%

20-19	SB	NB
IN	125	90
OUT	145	323
Diff	16%	259%

24-25	NB	SB
IN	720	732
OUT	678	767
Diff	-6%	5%

28-29	WB	EB
IN	610	936
OUT	604	936
Diff	-1%	0%

20-21	EB	WB
IN	147	104
OUT	140	75
Diff	-5%	-28%

26-25	NB	SB
IN	802	871
OUT	846	856
Diff	5%	-2%

30-29	WB	EB
IN	700	774
OUT	700	826
Diff	0%	7%

23-21	NB	SB
IN	96	269
OUT	140	254
Diff	46%	-6%

Following best practice guidelines, surveys collected on the same date with flow differences above 5% have been subject to a detailed analysis in section 2.3.2. There are no guideline stating a threshold flow difference for traffic surveys done on a different day however we decided to use a 15% threshold based on Arcadis best practice. This 15% threshold allow to identify gaps within the traffic survey which need to be addressed.

2.3.2 Traffic Flow Difference Analysis and Recommendations

This section presents a detailed analysis of the traffic surveys where the difference between in and out flows recorded through adjacent junctions is greater than 15%. Recommendations are also given in regard to the actions involved in the modelling process.

2.3.2.1 Junctions 22-21



AM			PM		
22-21	EB	WB	22-21	EB	WB
IN	189	272	IN	331	122
OUT	182	310	OUT	309	137
Diff	-4%	15%	Diff	-7%	12%

Both junctions were surveyed on October 13th 2016.

The difference could be explained by the presence of a residential access road (Octavian Drive). There is no vehicle access between Aldington Road and Berwick Lane (Pedestrian only).

Modelling Recommendation: A zone near Octavian Drive can be added to represent flows coming in and out of the residential area.

2.3.2.2 Junctions 11-14

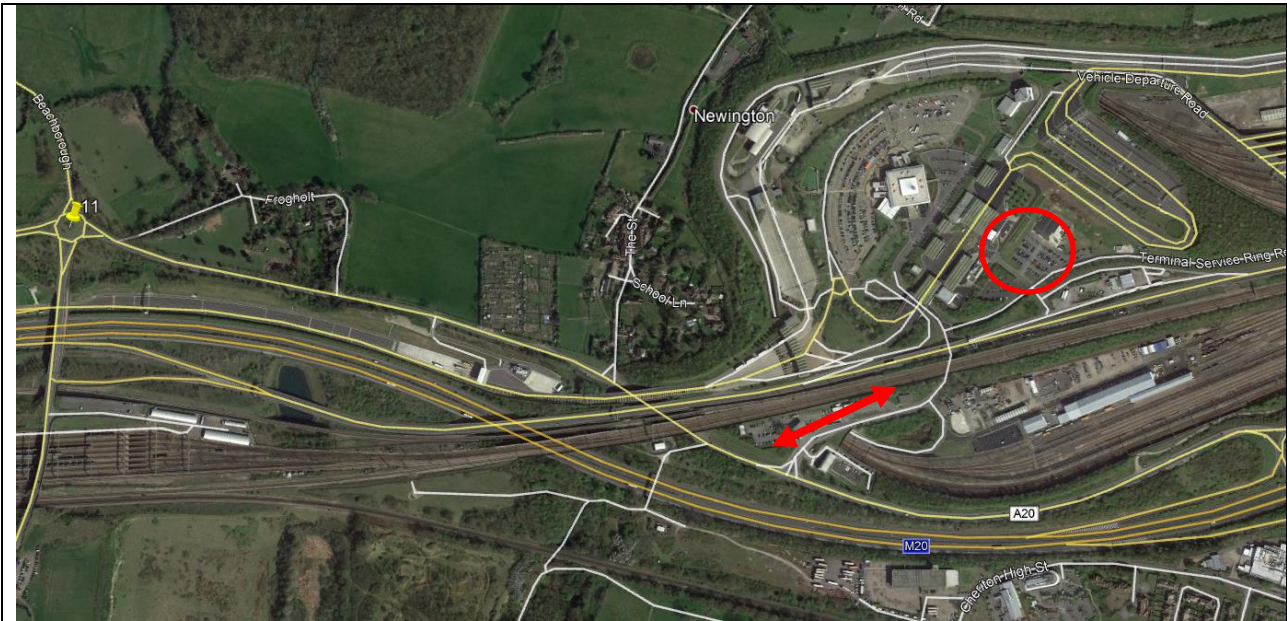

AM			PM		
11-14	WB	EB	11-14	WB	EB
IN	605	541	IN	502	411
OUT	412	606	OUT	471	624
Diff	-32%	12%	Diff	-6%	52%

Both junctions were surveyed on June 29th 2017.

The difference is likely to be explained by the presence of one of the Terminal Service Roads of the Eurotunnel, providing access to one of the main staff buildings and car parks.

Modelling Recommendation: A new link (Terminal Service Road) and zone (Car park) can be added to the current network in order to represent the traffic generated/attracted by the buildings and car parks.

2.3.2.3 Junctions 10-11

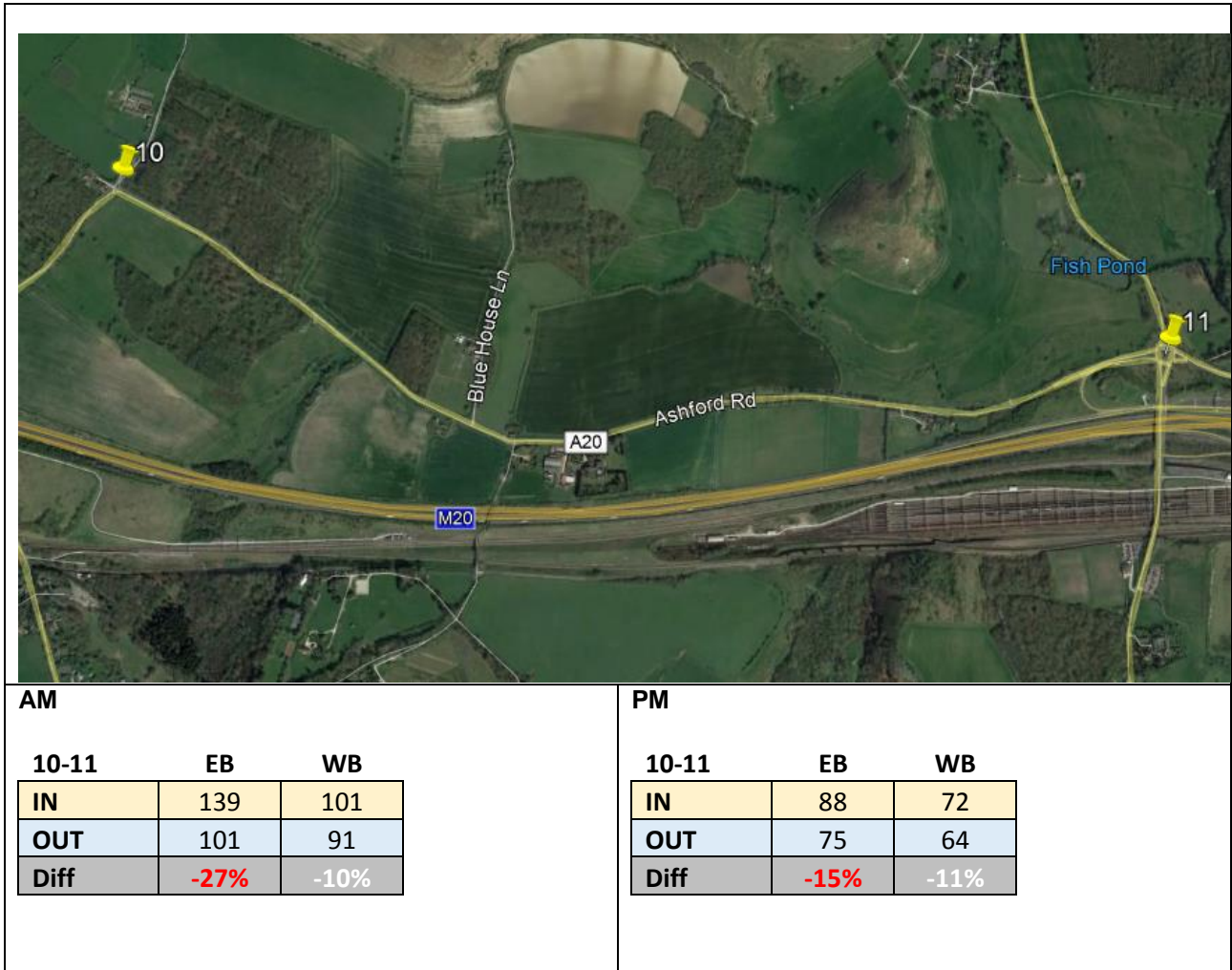

Site 10 was surveyed on October 13th 2016 and Site 11 was surveyed on June 29th 2017.

The westbound difference could be explained by the slip road connecting to the Eurotunnel entrance from site 11. However, there are no relevant intermediate junctions between the two sites in the eastbound flow, which suggests that the flow difference could be attributed by the date difference between the two traffic surveys.

Modelling Recommendation: A new zone can be created to represent the Eurotunnel entrance in regards of the westbound flow difference. In terms of the eastbound flow difference, both sets of data (eastbound flows from the two surveys) should be growth separately assuring flows are balanced in the baseline scenario year.

2.3.2.4 Junctions 32-33

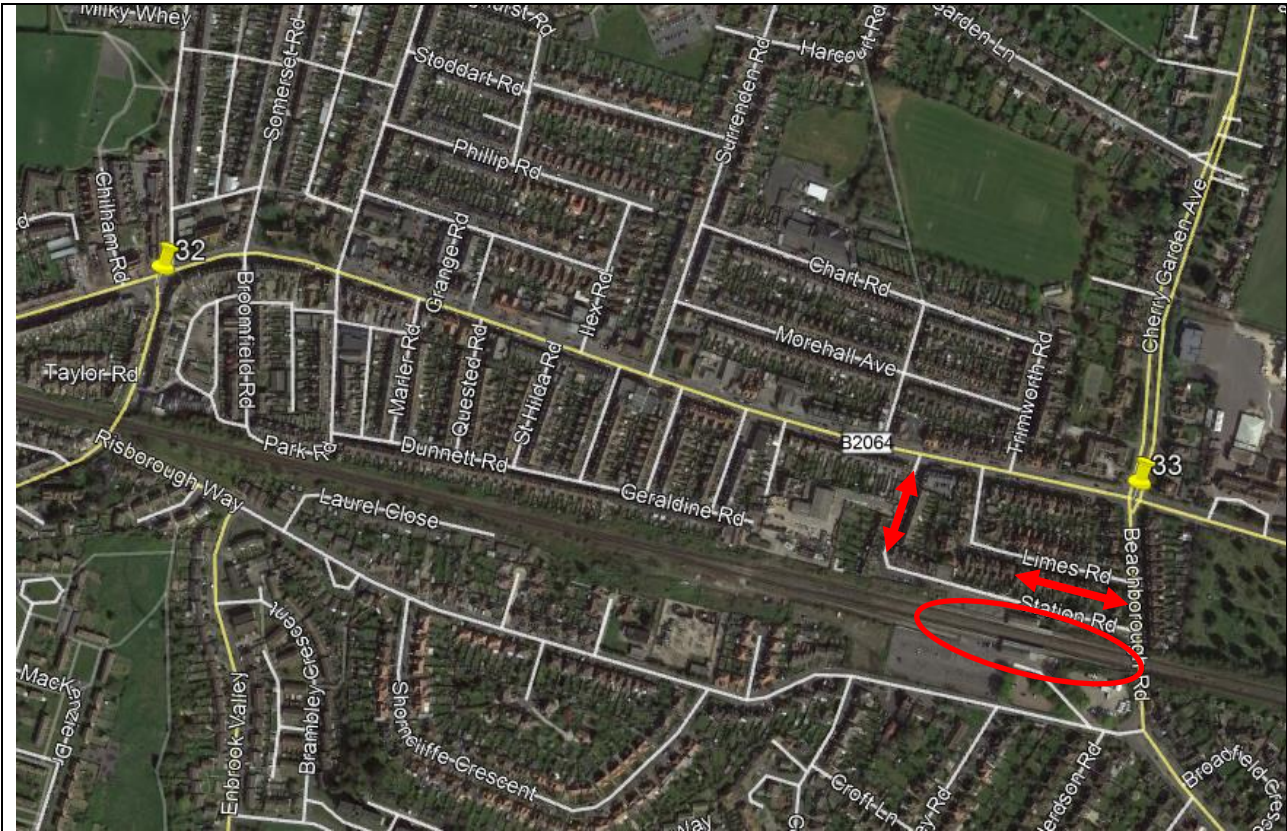

AM			PM		
32-33	WB	EB	32-33	WB	EB
IN	332	537	IN	351	685
OUT	474	562	OUT	533	617
Diff	43%	5%	Diff	52%	-10%

Both junctions were surveyed on June 29th 2017.

This is mainly a residential area with a railway station (Folkestone West) on Station Road, which is between the two surveyed junctions. The difference could be attributed to the traffic dynamic created by the presence of the railway station and the several access roads to residential developments in the vicinity of the junctions.

Modelling Recommendation: Two zones can be created; one zone south of Cheriton Road to represent the flow from/to the railway station and the residential developments south of the main road, and another zone north of Cheriton Road to represent the residential developments on that side of the main road.

2.3.2.5 Junctions 14-31

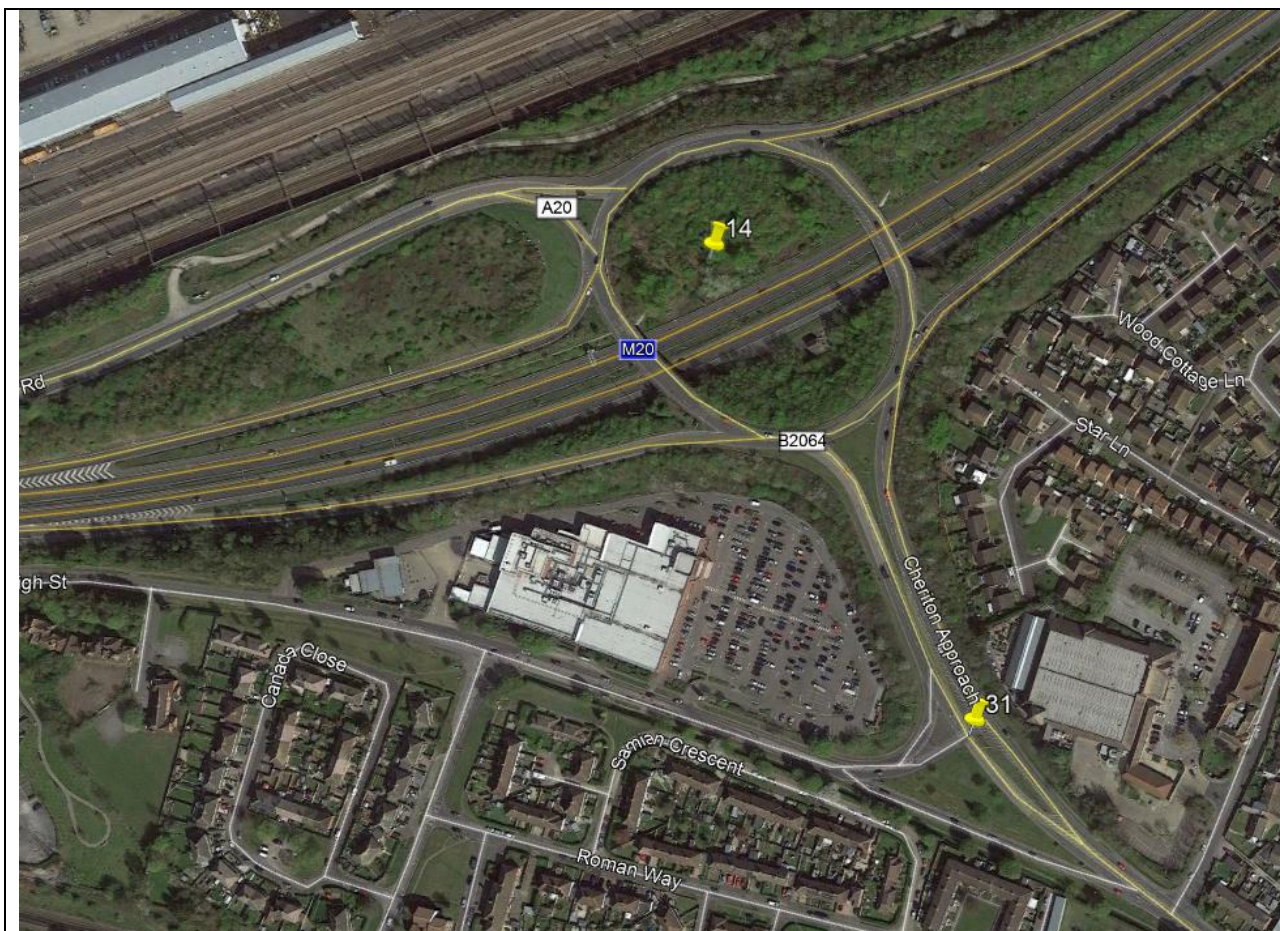

AM			PM		
14-31	EB	WB	14-31	EB	WB
IN	1126	927	IN	1358	1083
OUT	1135	1117	OUT	1208	1135
Diff	1%	20%	Diff	-11%	5%

Site 31 was surveyed on October 22nd 2013 and Site 14 was surveyed on June 29th 2017.

The only plausible reason for the given gap is the date difference between the surveys (more than 3 years).

Modelling Recommendation: Both sets of data will be growth separately making sure flows are balanced in the baseline scenario year. No further action to be taken.

2.3.2.6 Junctions 6-5



AM

6-5	WB	EB
IN	408	449
OUT	528	380
Diff	29%	-15%

PM

6-5	WB	EB
IN	371	577
OUT	445	526
Diff	20%	-9%

Both junctions were surveyed by on June 29th 2017.

The difference could be explained by the presence of an alternative route for the residents of Brabourne Lees travelling west; they could use The Ridgeway to access/exit the A20 instead of going through the A20/Church Road junction.

Modelling Recommendation: A new zone can be created to represent the traffic flow using the alternative route.

2.3.2.7 Junctions 32-31



AM			PM		
32-31	EB	WB	32-31	EB	WB
IN	568	580	IN	746	663
OUT	477	637	OUT	685	618
Diff	-16%	10%	Diff	-8%	-7%

Site 31 was surveyed on October 22nd 2013 and Site 32 was surveyed on June 29th 2017.

Apart from the date difference (more than 3 years) there are two roads that could potentially explain the flow differences; Firs Lane provides access to a home, garden and goods retailer with nearly 100 parking spaces, and Weymouth Road, provides access to several residential developments north of site 31.

Modelling Recommendation: A single zone north of the site 31 can be added to represent both; the residential area and the retail centre in/out traffic flows.

2.3.2.8 Junctions 8-19

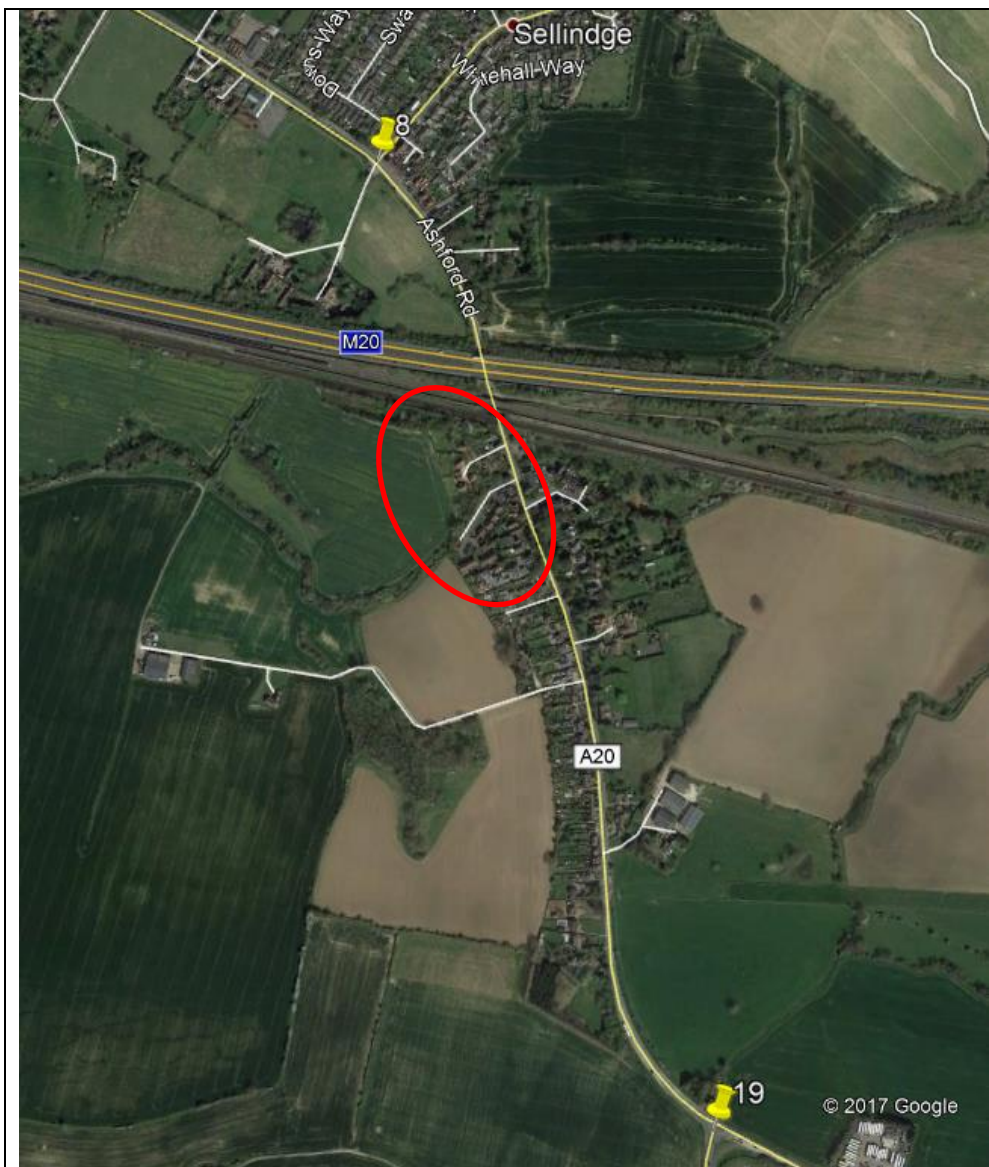

AM			PM		
8-19	EB	WB	8-19	EB	WB
IN	258	266	IN	313	258
OUT	254	314	OUT	271	271
Diff	-2%	18%	Diff	-13%	5%

Both junctions were surveyed on October 13th 2016.

The difference could be explained by the presence of a series of small residential developments between the two junctions.

Modelling Recommendation: A single zone with a linked to either way of the A20 can be added to represent the traffic flows from/to the residential area.

2.3.2.9 Junctions 20-19

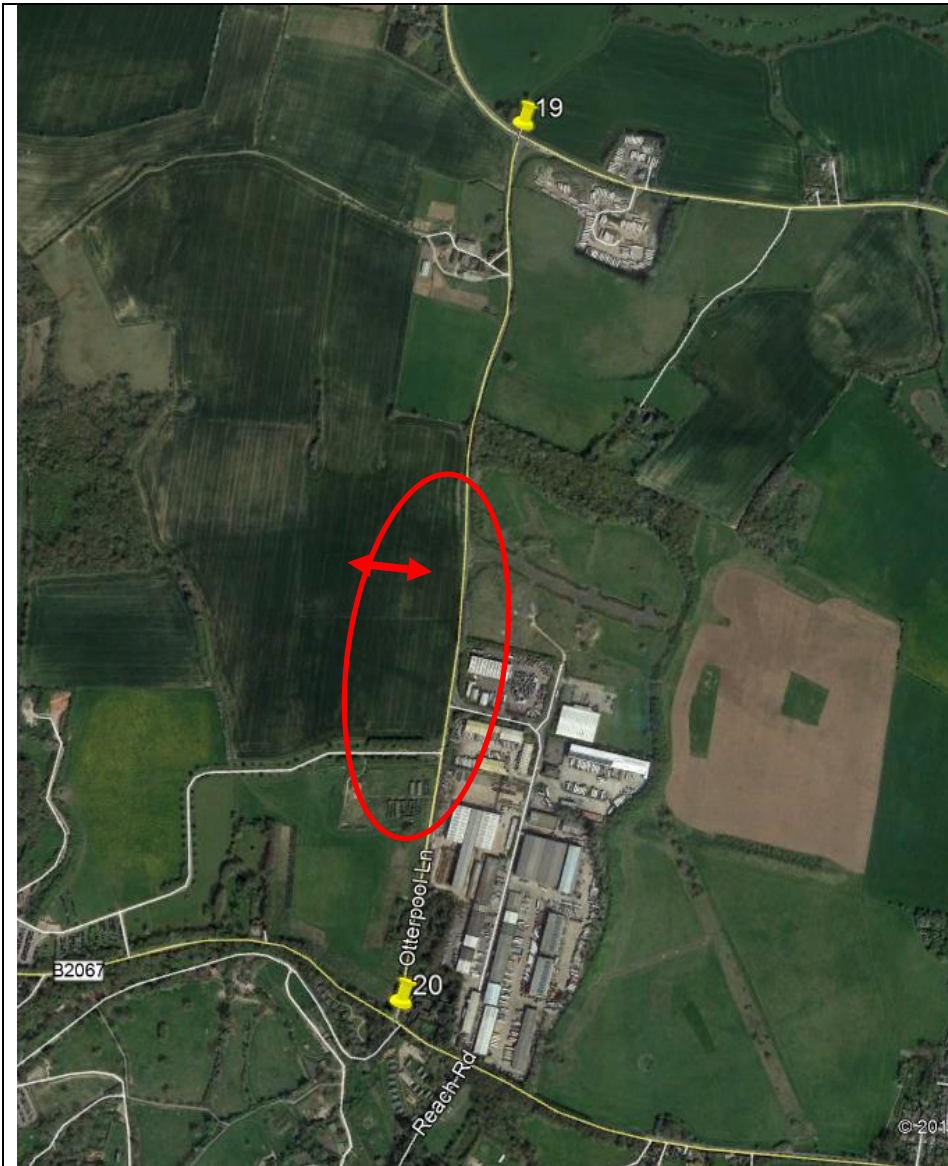

AM			PM		
20-19	SB	NB	20-19	SB	NB
IN	245	190	IN	125	90
OUT	98	196	OUT	145	323
Diff	-60%	3%	Diff	16%	259%

Both junctions were surveyed on October 13th 2016.

The difference could be explained by the presence the Lympe Industrial Park between the two junctions attracting trips in the AM period and generating them in the PM.

Modelling Recommendation: A zone can be added to represent the main entrance/exit of the Lympe Industrial Park.

2.3.2.10 Junctions 20-21



AM			PM		
20-21	EB	WB	20-21	EB	WB
IN	92	183	IN	147	104
OUT	80	136	OUT	140	75
Diff	-13%	-26%	Diff	-5%	-28%

Both junctions were surveyed on October 13th 2016.

There are two places between the two junctions that could potentially attract trips in both periods. A road access to the Port Lymgne mansion which is now a hotel and a conference centre near site 20 and a residential development on beacon way, near site 21 with approximately 40 dwellings.

Modelling Recommendation: A zone between site 20 and site 21 can be added to represent the flows entering/exiting the residential development and the Port Lymgne Hotel.

2.3.2.11 Junctions 23-21

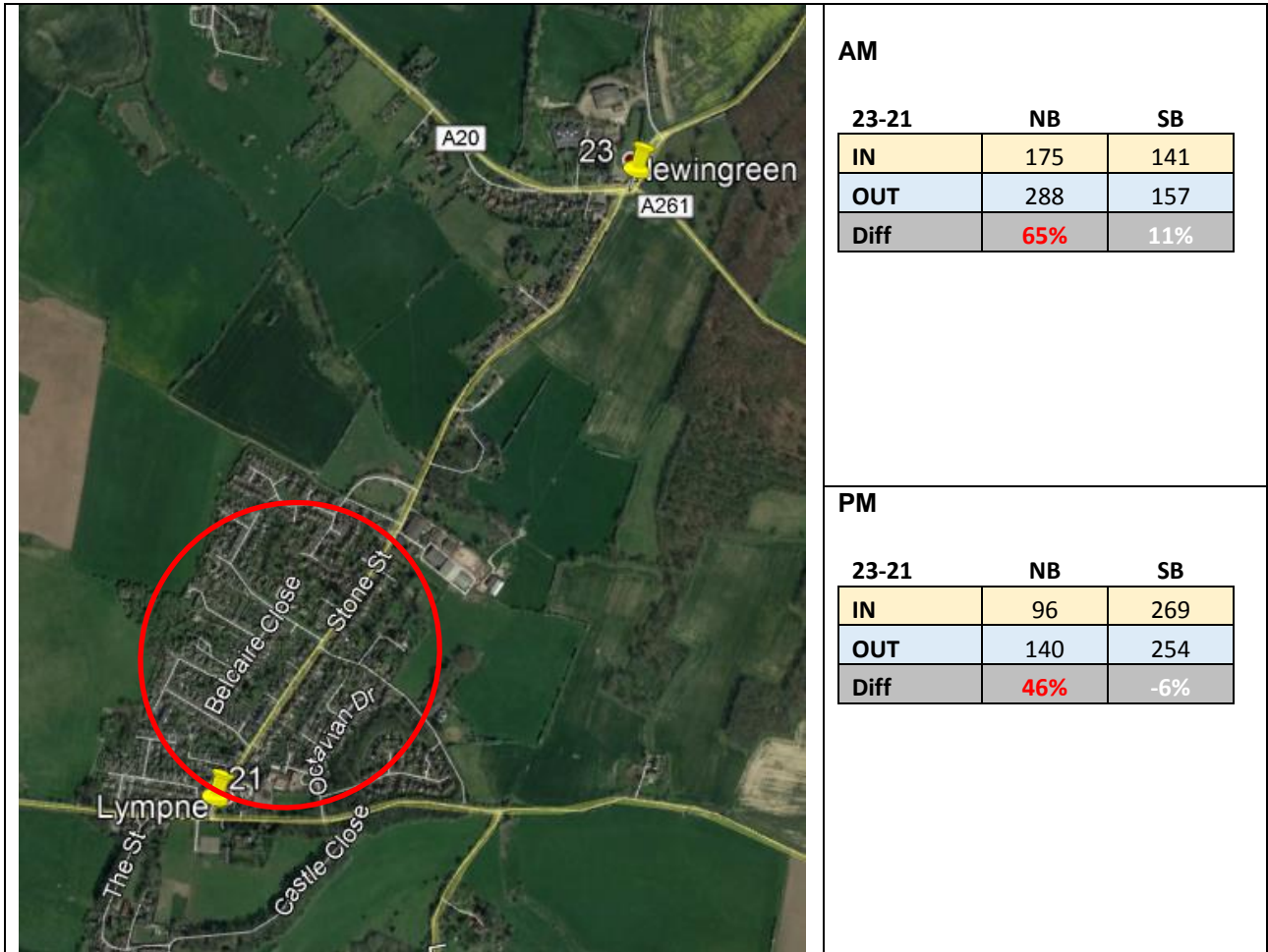

Site 21 was surveyed on October 13th 2016 and Site 23 was surveyed on June 29th 2017.

Even though part of the difference could be explained by the date difference, there are 4 access roads to at least 100 dwellings between the two junctions.

Modelling Recommendation: A single zone linked to either way of Stone Street can be added to represent the traffic flows from/to the residential area.

2.3.2.12 Junctions 6-7

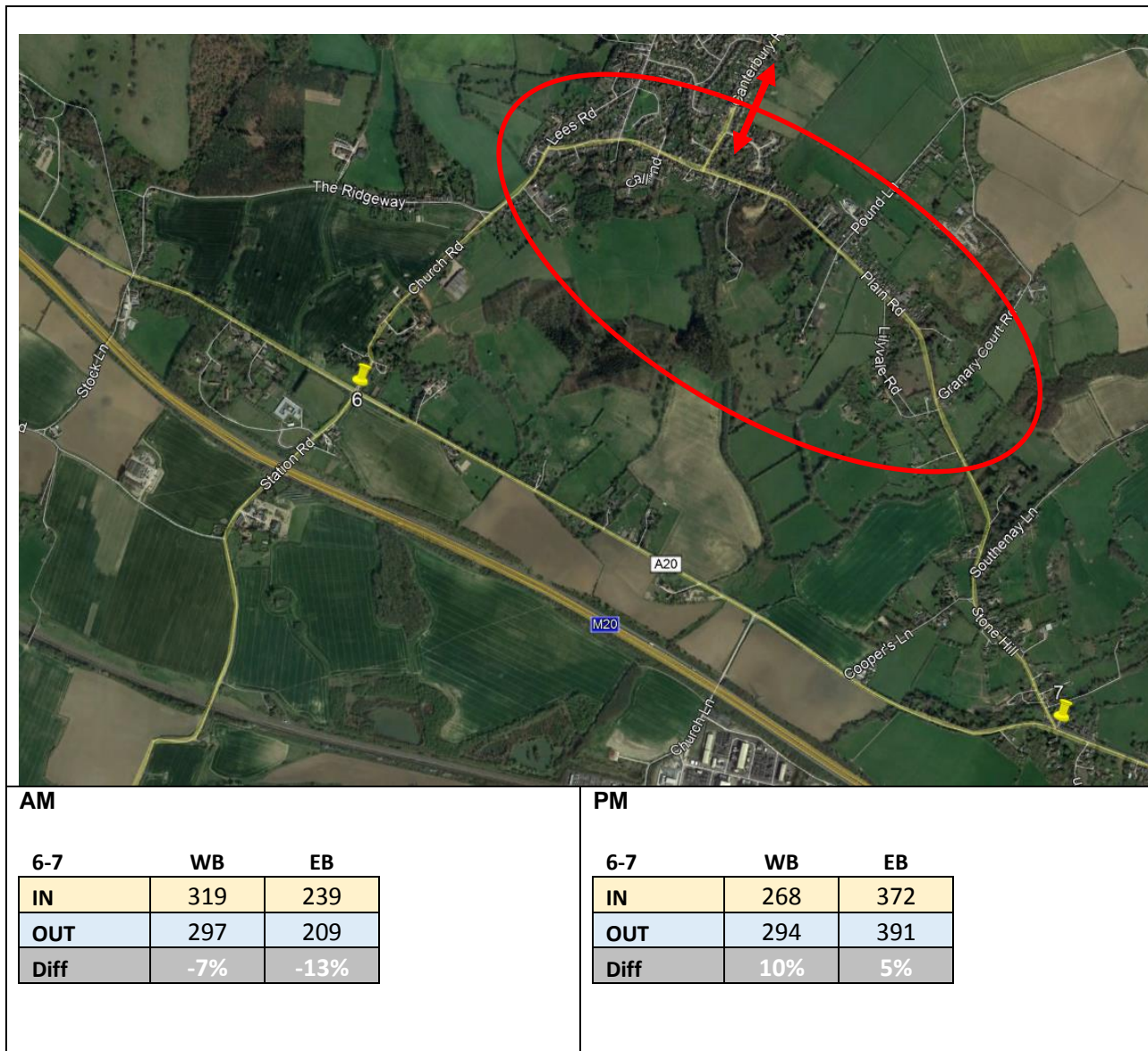

Both junctions were surveyed by on June 29th 2017.

The difference could be explained by the presence of a series of secondary roads providing access to small settlements both sides of the A20.

Modelling Recommendation: A single zone linked to either way of the A20 can be added to represent the traffic flows leaving/entering the A20.

2.3.2.13 Junctions 4-5

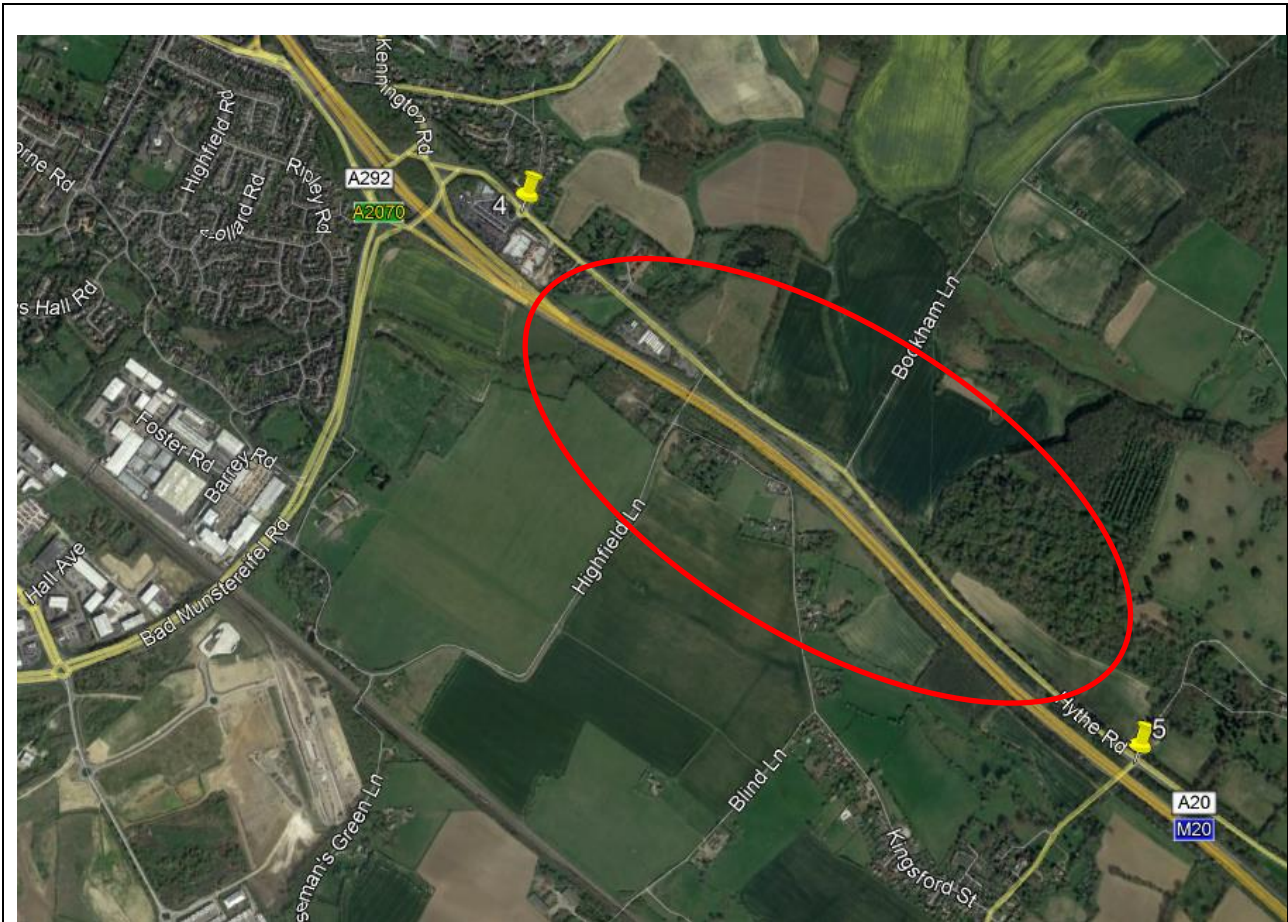

AM			PM		
4-5	WB	EB	4-5	WB	EB
IN	611	548	IN	486	698
OUT	627	522	OUT	504	654
Diff	3%	-5%	Diff	4%	-6%

Both junctions were surveyed by on June 29th 2017.

The difference could be explained by the presence of a series of rural access roads both sides of the Hythe Road.

Modelling Recommendation: Given the small differences in vehicles, there is no need to create a new zone among the two junctions, however, special care should be taken during the calibration process. The difference between the two junctions is likely to drop because of the planning closure of the junction Highfield Lane / A20 due to the M20 Junction 10a construction works.

2.3.2.14 Junctions 30-29

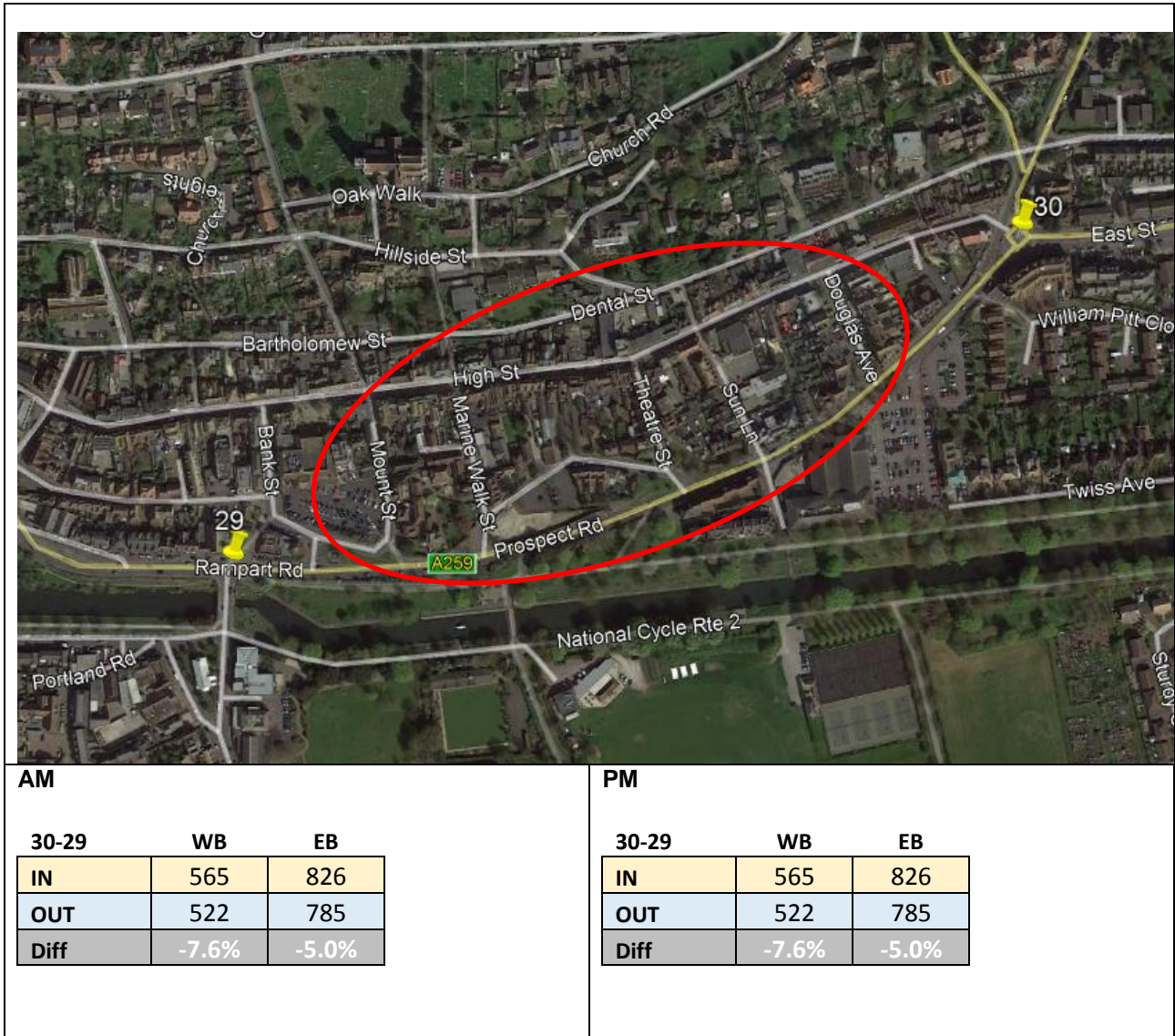

Both junctions were surveyed by on June 29th 2017.

The difference could be explained by the presence of a series of residential access roads north side of Prospect Road and an Aldi supermarket car park.

Modelling Recommendation: Based on the short number of vehicles “lost” between the two junctions, there is no need to create a new zone, however, special care should be taken during the calibration process.

2.4 Comparison of 2013, 2016 and 2017 survey data in adjacent junctions

Table 6 presents an additional analysis between adjacent junctions surveyed in different years, regardless of the difference percentage.

Table 6 Traffic flow difference between adjacent junctions surveyed in different years.

Link	Site Code	Survey Date	Traffic flow	AM (08:00 - 09:00)		PM (17:00 - 18:00)		Observation
				EB	WB	EB	WB	
			Direction of Flow	EB	WB	EB	WB	
7-8	7	29/06/2017	In	284	-	431	-	The differences are relatively marginal, with no relevant intermediate junctions between the two sites.
			Out	-	374	-	315	
	8	13/10/2016	In	-	397	-	283	
			Out	290	-	412	-	
			<i>Difference</i>	-2.1%	-5.8%	-4.4%	-10.2%	
			Direction of Flow	NB	SB	NB	SB	
23-21	23	29/06/2017	In		141		269	As explained in section 2.3.2.13, along with the date difference, there are 4 access roads to at least 100 dwellings between the two junctions.
			Out	288		140		
	21	13/10/2016	In	175		96		
			Out		157		254	
			<i>Difference</i>	64.6%	-10.2%	45.8%	5.9%	
			Direction of Flow	EB	WB	EB	WB	
11-10	11	29/06/2017	In		101		72	The Westbound (WB) difference could be explained by the slip road connecting to the Eurotunnel entrance from site 11. However, there are no relevant intermediate junctions between the two sites in the Eastbound (EB) flow
			Out	101		75		
	10	13/10/2016	In	139		88		
			Out		91		64	
			<i>Difference</i>	-27.3%	11.0%	-14.8%	12.5%	
			Direction of Flow	EB	WB	EB	WB	
14-31	14	29/06/2017	In	1126		1358		The only plausible reason for the given difference is the date difference between the surveys (more than 3 years).
			Out		1117		1135	
	31	22/10/2013	In		927		1083	
			Out	1135		1208		
			<i>Difference</i>	-0.8%	20.5%	-11.0%	-4.6%	

Otterpool Park
Traffic Survey Data Analysis

Link	Site Code	Survey Date	Traffic flow	AM (08:00 - 09:00)		PM (17:00 - 18:00)		Observation
			Direction of Flow	EB	WB	EB	WB	
32-31	32	29/06/2017	In		580		663	Apart from the date difference (more than 3 years) there are two roads that could potentially explain the flow differences; Firs Lane provide access to the "range", a home, garden & goods retailer with nearly 100 park spaces. And Weymouth Road, which provides access to several residential developments north of the B2064
			Out	477		685		
	31	22/10/2013	In	568		746		
			Out		637		618	
	Difference			-16.0%	-8.9%	-8.2%	7.3%	
			Direction of Flow	NB	SB	NB	SB	
26-9	26	29/06/2017	In	975		846		With no evident developments between the two junctions, the only plausible reason for the flow variation is the date difference between the surveys
			Out		869		1020	
	9	13/10/2016	In		826		986	
			Out	928		744		
	Difference			5.1%	5.2%	-12.1%	-3.3%	
			Direction of Flow	NB	SB	NB	SB	
24-25	24	29/06/2017	In	727		720		With no intermediate junctions between the two sites and a distance less than 200 metres amongst the two junctions. It is suggested that the flow difference is attributed to the season variation.
			Out		662		767	
	25	13/10/2016	In		713		732	
			Out	728		678		
	Difference			-0.1%	-7.2%	-5.8%	-4.6%	
			Direction of Flow	NB	SB	NB	SB	
26-25	26	29/06/2017	In		920		871	With no intermediate junctions between the two sites and a distance less than 200 metres amongst the two junctions. It is suggested that the flow difference is attributed to the season variation.
			Out	975		846		
	25	13/10/2016	In	980		802		
			Out		964		856	
	Difference			-0.5%	-4.6%	5.5%	1.8%	

2.5 Forecast Traffic Flows for Future Case Modelling

Three baseline scenarios will be modelled, as follows:

1. Application year – 2018;
2. End of local plan – 2037; and
3. Opening year with full occupation – year to be determined.

We proposed to use the NTM AF15 dataset and TEMPro v7.2, updated with the latest household and job forecasts to be provided by Kent County Council and Folkstone & Hythe District Council, to growth the 2016 and 2017 traffic surveys to 2018 for the application year scenario.

The baseline flows for the 2037 scenario will be based on a combination of growth factors from TEMPro. We will then apply TEMPro factor to growth the flows to the opening year.

3 Origin-Destination (OD) surveys

An Automatic Number Plate Recognition (ANPR) survey has been undertaken for a 12-hour period, between 07:00 and 19:00 on the same day as the classified turning counts in June 2017. During this period, vehicle registration plates have been recorded by vehicle type: light vehicles, heavy vehicles and public service vehicles (PSV) in 62 cameras located along the study area. ANPR provides information of the routes used by vehicles and number of vehicles using these routes within the study area.

The location of the cameras can be found in Appendix A.

Journey times will be extracted from the OD surveys. During the OD surveys, the vehicle registration plates were recorded together with a “time-stamp”. This allows extraction of journey times between the various camera locations. It is noted that only journey times within the 90th percentile have been taken into account, as it has been assumed that journey times outside this range mean that a vehicle has done intermediate stops within the network before arriving to the destination point.

Table 7 presents the capture rate of registered vehicles per ANPR site. The overall captured rate is above 85% for the AM and PM peak period, only two sites (43 and 46) registered a capture rate below 85%. The small number of sites with a match lower than 85% gives us a high degree of confidence in the surveys quality.

Otterpool Park
Traffic Survey Data Analysis

Table 7. Registered percentage of vehicles in the ANPR

ANPR site	8:00-9:00			17:00-18:00		
	MCC	ANPR	% registered	MCC	ANPR	% registered
01	1744	1690	97%	1856	1781	96%
02	347	326	94%	403	398	99%
03	1612	1564	97%	1518	1465	97%
04	2485	2367	95%	3430	3231	94%
05	690	682	99%	320	316	99%
06	457	446	98%	675	666	99%
07	135	128	95%	129	125	97%
08	197	190	96%	161	158	98%
09	1641	1542	94%	1935	1883	97%
10	1723	1645	95%	2018	1925	95%
11	116	114	98%	122	115	94%
12	120	120	100%	80	80	100%
13	97	97	100%	147	145	99%
14	107	106	99%	52	50	96%
15	79	78	99%	129	128	99%
16	130	127	98%	87	83	95%
17	61	59	97%	48	44	92%
18	73	72	99%	42	42	100%
19	94	91	97%	178	174	98%
20	180	175	97%	131	129	98%
21	375	372	99%	384	382	99%
22	349	338	97%	402	398	99%
23	156	154	99%	159	152	96%
24	172	169	98%	121	119	98%
25	267	263	99%	312	309	99%
26	277	274	99%	283	275	97%
27	64	55	86%	125	122	98%
28	156	153	98%	130	126	97%
29	335	325	97%	504	500	99%
30	389	382	98%	282	280	99%
31	107	99	93%	214	194	91%
32	224	211	94%	94	93	99%
33	339	335	99%	556	554	100%
34	410	406	99%	311	309	99%
35	285	272	95%	519	508	98%
36	386	385	100%	290	282	97%
37	669	635	95%	763	727	95%
38	729	711	98%	720	707	98%
39	221	220	100%	258	252	98%
40	264	259	98%	144	143	99%
41	179	174	97%	239	232	97%
42	267	262	98%	200	197	99%
43	379	302	80%	285	276	97%
45	1330	1184	89%	1870	1753	94%
46	2673	2275	85%	1728	1357	79%
47	216	213	99%	142	140	99%
48	208	206	99%	146	143	98%
49	27	25	93%	13	13	100%
50	1	1	100%	6	6	100%
51	36	36	100%	28	28	100%
52	101	100	99%	168	165	98%
53	505	501	99%	823	820	100%
54	921	909	99%	682	664	97%
55	225	223	99%	224	221	99%
56	357	348	97%	337	334	99%
57	607	600	99%	685	679	99%
58	532	499	94%	678	670	99%

4 Conclusion

Traffic flow differences between sites have been observed and explained. The structure of the VISSIM and VISUM models will provide additional zones and network structures to mitigate these differences where required.

Some discrepancies between data of difference ages have been identified at some locations but most of the data is acceptable. A decision will be made during the validation of the VISUM model to readjust the 2016 surveys to reduce the gaps but at this point the analysis shows that it is not a source of concern and does not need immediate mitigation.

The ANPR data shows a good sample rate against manual turning count and also shows that the data can be used to capture the journey time.

Overall the data check has shown no significant issues with the data set and demonstrated that the data is fit for purpose. It is proposed to proceed with the traffic modelling with this data set.

APPENDIX A

ANPR Camera locations



Otterpool Park
Traffic Survey Data Analysis

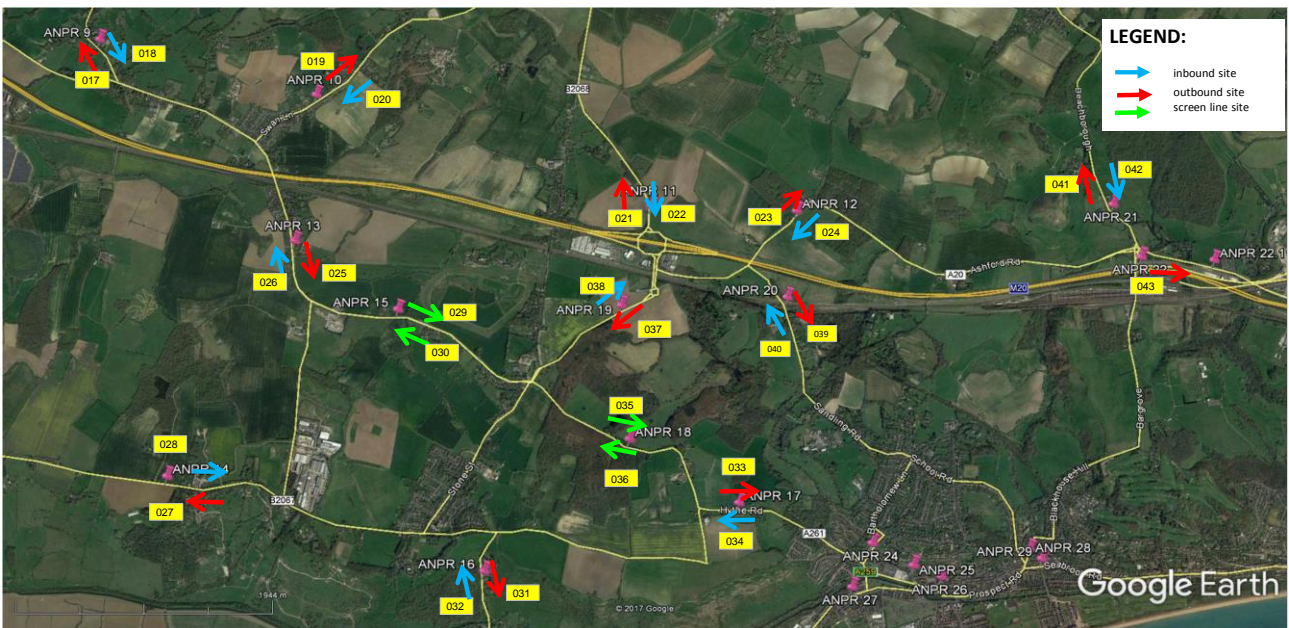

Otterpool Park
Traffic Survey Data Analysis



APPENDIX B

Classified Turning Counts (Summary)

Time (Starting hour)	PERIOD	HOURLY FLOWS										
		CAR	TAXI	LGV	OGV 1	OGV 2	BUS	COACH	MCY	PCY	TOTAL	Only motorised
07:00	AM	35,628	4	7,507	948	1,149	279	365	326	109	46,315	46,206
07:15		41,688	4	7,855	1,007	1,103	309	400	316	103	52,785	52,682
07:30		46,670	4	7,695	1,124	1,092	300	398	317	90	57,690	57,600
07:45		49,727	4	7,325	1,239	1,071	259	398	296	68	60,387	60,319
08:00		50,382	8	6,728	1,298	1,061	247	419	285	71	60,499	60,428
08:15		47,750	16	6,376	1,341	1,091	220	405	274	61	57,534	57,473
08:30		43,788	19	6,134	1,349	1,196	243	404	236	69	53,438	53,369
08:45		38,681	23	5,933	1,285	1,174	228	388	242	74	48,028	47,954
09:00		34,639	22	5,803	1,333	1,196	234	385	222	111	43,945	43,834
09:15	Off Peak*	23,296	13	3,647	873	601	165	306	146	94	29,141	29,047
09:30		22,581	10	3,520	884	541	172	289	153	85	28,235	28,150
09:45		22,617	10	3,412	948	551	178	264	142	81	28,203	28,122
10:00		22,591	8	3,412	903	546	162	211	177	57	28,067	28,010
10:15		22,690	8	3,433	884	550	165	205	173	71	28,179	28,108
10:30		23,129	9	3,437	881	548	156	200	164	79	28,603	28,524
10:45		23,322	7	3,457	861	514	164	209	153	84	28,771	28,687
11:00		23,492	5	3,363	845	469	169	213	118	71	28,745	28,674
11:15		23,934	4	3,398	799	442	168	222	143	61	29,171	29,110
11:30		24,055	5	3,458	826	460	172	216	164	48	29,404	29,356
11:45		24,223	5	3,475	780	480	164	203	161	38	29,529	29,491
12:00		24,459	10	3,470	772	492	174	212	170	28	29,787	29,759
12:15		24,618	10	3,399	766	516	168	217	157	41	29,892	29,851
12:30		24,496	12	3,335	719	499	155	237	158	64	29,675	29,611
12:45		24,537	16	3,384	748	484	160	240	188	93	29,850	29,757
13:00		24,432	17	3,449	773	501	163	225	202	99	29,861	29,762
13:15		24,464	22	3,601	826	511	167	259	194	94	30,138	30,044
13:30		25,300	25	3,657	819	516	171	276	176	95	31,035	30,940
13:45		25,981	19	3,637	760	518	181	308	147	85	31,636	31,551
14:00		26,721	16	3,713	702	535	173	330	131	92	32,413	32,321
14:15		27,406	13	3,748	631	513	176	304	179	92	33,062	32,970
14:30	27,939	11	3,816	632	518	184	327	182	76	33,685	33,609	
14:45	28,381	16	3,991	658	513	169	312	207	70	34,317	34,247	
15:00	28,692	17	4,046	655	502	176	316	216	58	34,678	34,620	
15:15	30,528	17	4,522	612	493	210	320	220	62	36,984	36,922	
15:30	31,059	14	4,798	578	505	189	280	276	58	37,757	37,699	
15:45	32,070	13	4,895	510	487	187	280	319	57	38,818	38,761	
16:00	PM	45,692	9	7,390	842	972	229	383	460	80	56,057	55,977
16:15		48,534	7	7,215	781	958	224	361	483	92	58,655	58,563
16:30		51,190	5	6,912	654	889	216	330	482	102	60,780	60,678
16:45		53,046	1	6,442	546	888	227	295	495	109	62,049	61,940
17:00		54,260	2	5,861	497	862	232	278	529	125	62,646	62,521

Otterpool Park
Traffic Survey Data Analysis

Time (Starting hour)	PERIOD	HOURLY FLOWS										
		CAR	TAXI	LGV	OGV 1	OGV 2	BUS	COACH	MCY	PCY	TOTAL	Only motorised
17:15		51,968	2	5,131	464	827	220	282	507	134	59,535	59,401
17:30		48,408	2	4,467	457	858	222	280	437	139	55,270	55,131
17:45		43,992	1	3,825	420	829	205	270	405	142	50,089	49,947
18:00		39,956	-	3,298	377	796	171	233	391	134	45,356	45,222

* Surveys conducted in 2016 did not include Off Peak hours.

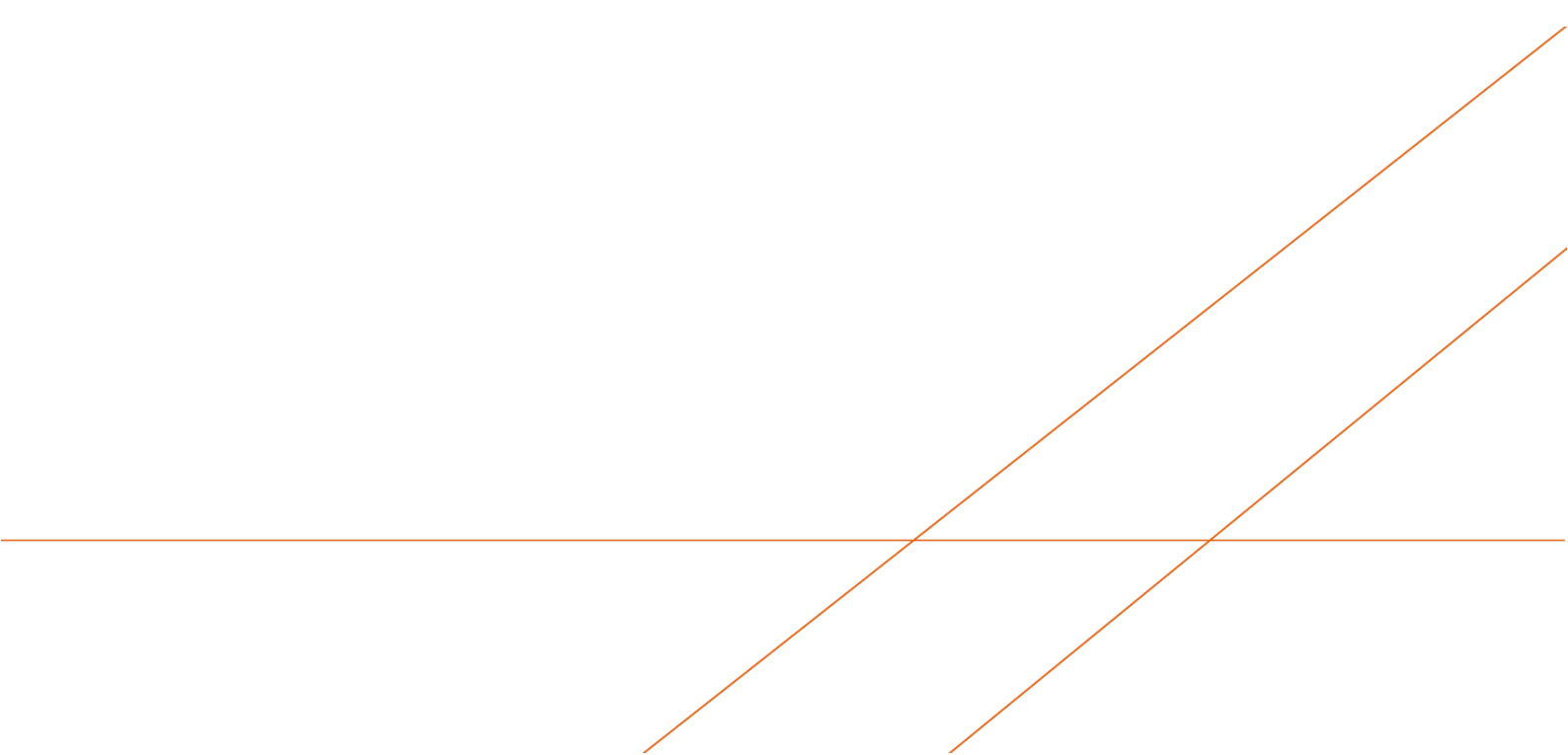

APPENDIX D – Modelling Validation Report (Folkstone & Hythe and Ashford)

OTTERPOOL PARK

Operational Modelling Validation Report

MAY 2018



CONTENTS

1	INTRODUCTION	1
1.1	Background.....	1
1.2	Structure of this Note	1
2	MODELLING OVERVIEW	3
2.1	Study Area.....	3
2.2	Software Packages Used	5
2.3	Time Periods	5
3	SURVEY DATA	6
3.1	Introduction.....	6
3.2	Traffic Counts	6
4	SIGNAL DATA	7
5	SIGNALISED JUNCTIONS	7
5.1	Junction 1: M20 Junction 10.....	8
5.2	Junction 9: B2067 Otterpool Lane / A20 Ashford Road.....	13
5.3	Junction 16: A259 / Military Road / Dymchurch Road (Hythe).....	14
5.4	Junction 24: B2064 Cheriton High Street / B2063 Risborough Lane / Stanley Road	18
5.5	Junction 25: B2064 Cheriton High Street / A2034 Cherry Garden Avenue.....	19
5.6	Junction 27: M20 Junction 9.....	20
5.7	Modelling assumptions.....	22
5.8	Model results.....	22
6	PRIORITY CONTROLLED ROUNDABOUTS	23
6.1	Junction description	23
6.2	Junction 2: M20 Junction 11.....	24
6.3	Junction 8: A20 Hythe Road / The Street	24
6.4	Junction 20: A259 Prospect Road / A259 Seabrook Road / Station Road / High Street (Hythe)	25
6.5	Junction 21: M20 J11A	26
6.6	Junction 22: M20 Junction 12	27
6.7	Junction 23: M20 Junction 13	28
6.8	Junction 28: A260 Spitfire Way / White Horse Hill / A20 Slip Roads	30
6.9	Junction 29: Alkham Valley Road / A20 Slip Roads.....	30
6.10	Modelling assumptions.....	31

6.11	Model results.....	31
7	PRIORITY CONTROLLED JUNCTIONS.....	33
7.1	Junction description	33
7.2	Junction 3: A20 Ashford Road / Swan Lane	34
7.3	Junction 4: A20 Ashford Road / Stone Hill	35
7.4	Junction 5: A20 Ashford Road / Station Road / Church Road	35
7.5	Junction 6: A20 Hythe Road / Mersham	36
7.6	Junction 7: A2070 Kennington Road / The Street	37
7.7	Junction 10: B2067 Otterpool Lane / Aldington Road	37
7.8	Junction 11: Aldington Road / Stone Street	38
7.9	Junction 12: A20 Ashford Road / A261 Hythe Road / Stone Street	39
7.10	Junction 13: Aldington Road / Lympe Hill	39
7.11	Junction 14: A261 Hythe Road / Aldington Road	40
7.12	Junction 15: A261 London Road / Barrack Hill.....	41
7.13	Junction 17: A20 Ashford Road / A20 Junction 11 offslip	41
7.14	Junction 18: A20 Ashford Road / Sandling Road	42
7.15	Junction 19: A20 Ashford Road / Stone Street	43
7.16	Junction 26: A259 Prospect Road / Stade Street	43
7.17	Junction 30: A260 Canterbury Road / Alkham Valley Road	44
7.18	Modelling assumptions	45
7.19	Model results.....	45
8	CONCLUSION.....	46
	APPENDIX A SURVEY DATA REPORT	47
	APPENDIX B.....	1
	Signal data. Electronic appendices	1
	APPENDIX C.....	2
	LinSig. Electronic appendices	2
	APPENDIX D.....	3
	ARCADY. Electronic appendices	3
	APPENDIX E.....	4
	PICADY. Electronic appendices	4

FIGURES

Figure 1. Junction modelling location	4
Figure 2. Location of signalised junctions.....	8
Figure 3. Junction 1 – M20 J10 – A292 Hythe Road arm	9
Figure 4. Junction 1 – M20 J10 – M20 eastbound offslip road arm	9
Figure 5. Junction 1 – M20 J10 – A2070 Kennington Road arm	9
Figure 6. A20 Hythe Road arm – M20 J10	10
Figure 7. Junction 1 – M20 J10 – A20 Hythe Road arm. Stream 1.....	10
Figure 8. Junction 1 – M20 J10 – A20 Hythe Road exit arm. Stream 2	11
Figure 9. Junction 1 – M20 J10 – M20 westbound offslip road arm.....	11
Figure 10. A2070 Bad Munstereifel Road arm – M20 J10	11
Figure 11. Junction 1 – M20 J10 – A2070 Bad Munstereifel Road arm. Stream 1	12
Figure 12. Junction 1 – M20 J10 – A2070 Bad Munstereifel Road exit arm. Stream 2	12
Figure 13. A292 Hythe Road / M20 westbound onslip road.....	12
Figure 14. Junction 1 –A292 Hythe Road / M20 westbound onslip road	13
Figure 15. B2067 Otterpool Lane / A20 Ashford Road.....	13
Figure 16. Junction 9 – B2067 Otterpool Lane / A20 Ashford Road	14
Figure 17. A261 London Road / A259 Scalons Bridge / Military Road / Green Lane	15
Figure 18. Junction 16 – A261 London Road / A259 Scalons Bridge / Military Road / Green Lane.....	15
Figure 19. A259 Scalons Bridge / A259 Dymchurch Road	16
Figure 20. Junction 16 – A259 Scalons Bridge / A259 Dymchurch Road.....	16
Figure 21. Junction 16 – Dymchurch Road pedestrian crossing.....	17
Figure 22. Junction 16 – Military Road pedestrian crossing.....	17
Figure 23. Junction 16 – A259 Scalons Bridge pedestrian crossing	17
Figure 24. B2064 Cheriton High Street / B2063 Risborough Lane / Stanley Road	18
Figure 25. Junction 24 – B2064 Cheriton High Street / B2063 Risborough Lane / Stanley Road	18
Figure 26. B2064 Cheriton High Street / A2034 Cherry Garden Avenue.....	19
Figure 27. Junction 25 – B2064 Cheriton High Street / A2034 Cherry Garden Avenue	20
Figure 28. Junction 27 – M20 J9 – M20 eastbound offslip road arm	20
Figure 29. Junction 27 – M20 J9 – A251 Trinity Road arm	21
Figure 30. Junction 27 – M20 J9 – M20 westbound offslip roadarm.....	21
Figure 31. Junction 27 – M20 J9 – A20 Fougères Way arm	21

Figure 32. Location of priority controlled roundabouts	23
Figure 33. M20 J11	24
Figure 34. A20 Hythe Road / The Street	25
Figure 35. A259 Prospect Road / A259 Seabrook Road / Station Road / High Street (Hythe)	26
Figure 36. M20 J11A	27
Figure 37. M20 J12	28
Figure 38. M20 eastbound slip roads / A20 Castle Hill Bridge	29
Figure 39. M20 westbound slip roads / A259 Churchill Avenue / A2034 Cherry Garden Avenue	29
Figure 40. A260 Spitfire Way / White Horse Hill / A20 Slip Roads	30
Figure 41. Alkham Valley Road / A20 Slip Roads	31
Figure 42. Location of priority-controlled junctions	34
Figure 43. A20 Ashford Road / Swan Lane	34
Figure 44. A20 Ashford Road / Stone Hill	35
Figure 45. A20 Ashford Road / Station Road / Church Road	36
Figure 46. A20 Hythe Road / Mersham	36
Figure 47. A2070 Kennington Road / The Street	37
Figure 48. B2067 Otterpool Lane / Aldington Road	38
Figure 49. Aldington Road / Stone Street	38
Figure 50. A20 Ashford Road / A261 Hythe Road / Stone Street	39
Figure 51. Aldington Road / Lympe Hill	40
Figure 52. A261 Hythe Road / Aldington Road	40
Figure 53. A261 London Road / Barrack Hill	41
Figure 54. A20 Ashford Road / A20 J11 offslip	42
Figure 55. A20 Ashford Road / Sandling Road	42
Figure 56. A20 Ashford Road / Stone Street	43
Figure 57. A259 Prospect Road / Stade Street	44
Figure 58. A260 Canterbury Road / Alkham Valley Road	44

TABLES

Table 1. List of modelled junctions	3
Table 2. Summary of Traffic Counts used in Otterpool modelling	6
Table 3. Signal control plans list	7
Table 4. List of signalised junctions	7

Table 5. Degree of saturation values for signalised junctions 22

Table 6. List of priority-controlled roundabouts 23

Table 7. RFC Values for Priority Controlled Roundabouts..... 32

Table 8. List of priority-controlled junctions 33

Table 9. RFC Values for Priority Controlled Junctions 45

1 Introduction

1.1 Background

Arcadis Consulting (UK) Limited was appointed in August 2016 to develop a masterplan and planning submission in respect of the proposed development called Otterpool Park.

In December 2016, a Feasibility and Capacity Study undertaken as part of Stage 1 of the masterplanning process included a high-level assessment of the capacity of the M20 Junction 11, investigating the existing operation of the junction and testing a number of development scenarios using trip forecasts from a high-level trip generation calculation exercise based on vehicle trip rates provided by Shepway District Council.

Following the initial high-level capacity assessment in January 2017, a Trip Model was developed to more accurately calculate the number of trips generated by the site, the mode of travel in which the trips will occur and the spatial distribution of the trips. The masterplan has been developed further and a planning application is due to be submitted in 2018.

Scoping discussions with Kent County Council, Shepway District Council and Highways England to agree the transport requirements for the planning application have been ongoing since May 2017. A Transport Assessment scoping note¹ containing the proposed modelling study area was issued in August 2017. Technical notes describing the proposed trip generation² and distribution³ method were submitted in May 2017 and July 2017 respectively. These reports will be updated prior to planning application submission. In February 2018, a Traffic Survey Data Analysis report⁴ containing an analysis of traffic survey data collected in the modelling study area along with further details of the proposed modelling and forecasting method was issued. This report is attached as Appendix A.

The highway authorities requested that local junctions most likely to be impacted by the development should be tested using a VISSIM model while a number of other junctions would be assessed using the appropriate LinSig, Arcady or Picady software. This LMVR will focus on the calibration and validation of the VISSIM model only.

A VISUM model of the entire modelling study area was also built to speed up the construction of the VISSIM matrices. The trip distribution from the assignment of the VISUM model has been exported to VISSIM as static and therefore the vehicle inputs and the route choice in VISSIM are coming from the strategic model. This Note summarises the scope, development and validation of the junction models for the base year AM and PM peak hours.

1.2 Structure of this Note

The structure of this technical note is as follows:

Chapter 2 Modelling Overview: model coverage and software used.

Chapter 3 Survey data: summary of the data used in developing and validating the base models.

Chapter 4 Signal data: summary of signal data source.

Chapter 5 Signalised junctions: this section describes the junctions modelled in LinSig, model assumptions and model results.

¹ Otterpool Park Garden Settlement Transport Assessment Scoping Report (August 2017)

² Otterpool Park Garden Settlement Trip Generation Calculation Method Technical Note (May 2017)

³ Otterpool Park Garden Settlement Method for the Distribution of External Vehicle Trips (July 2017)

⁴ Otterpool Park Garden Settlement Traffic Survey Data Analysis (February 2018)

Chapter 6 Priority controlled roundabouts: this section describes the junctions modelled in ARCADY, model assumptions and model results.

Chapter 7 Priority controlled junctions: this section describes the junctions modelled in PICADY, model assumptions and model results.

Chapter 8 Conclusion: summary of the base model development and a recommendation as to whether the models are suitable for the intended purposes.

2 Modelling Overview

2.1 Study Area

A number of junctions have been assessed in individual junction models. Table 1 summarises the list of junctions modelled and Figure 1 shows the locations of these junctions.

Table 1. List of modelled junctions

No.	Junction	Type
1	M20 J10	Signalised roundabout
2	M20 J11	Non-signalised roundabout
3	Ashford Road (A20) / Swan Lane	Priority junction
4	Ashford Road (A20) / Stone Hill	Priority junction
5	Ashford Road (A20) / Station Road / Church Road	Priority junction
6	Hythe Road (A20) / Meersham	Priority junction
7	A2070 Kenniton Road / The Street	Priority junction
8	Hythe Road (A20) / The Street	Priority roundabout
9	A20 Ashford Road / B2067 Otterpool Lane	Signalised junction
10	B2067 Otterpool Lane / Aldington Road	Priority junction
11	Aldington Road / Stone Street	Priority junction
12	A20 Ashford Road / A261 Hythe Road / Stone Street	Priority junction
13	Aldington Road / Lympne Hill	Priority junction
14	A261 Hythe Road / Aldington Road	Priority junction
15	A261 London Road / Barrack Hill	Priority junction
16	A259 / Dymchurch Road / Military Road	Signalised gyratory
17	A20 Ashford Road / A20 J11 offslip	Priority junction
18	Ashford Road (A20) / Sandling Road	Priority junction
19	A20 Ashford Road / Stone Street	Priority junction
20	A259 Prospect Road / A259 Seabrook Road / Station Road / High Street	Priority roundabout
21	M20 J11A	Priority roundabout
22	M20 J12	Priority roundabout
23	M20 J13	Priority roundabout
24	B2064 Cheriton High Street / B2063 Risborough Lane	Signalised junction
25	B2064 Cheriton High Street / A2034 Cherry Garden Avenue	Signalised junction
26	A259 Prospect Road / Stade Street	Priority junction
27	M20 J9	Signalised roundabout
28	A260 Spitfire Way / White Horse Hill / A20 Slip Roads	Priority roundabout
29	Alkham Valley Road / A20 slip roads	Priority roundabout
30	A260 Canterbury Road / Alkham Valley Road	Priority junction

2.2 Software Packages Used

Drawings provided by Kent County Council and Highways England, in conjunction with online mapping and Google Street view and other appropriate tools were used to ensure that geometric parameters were correctly calculated for all junction models developed.

ARCADY 6 software package was used where priority controlled roundabouts were to be modelled. ARCADY is a junction modelling package used for predicting capacities, queues and delays at priority roundabout junctions, taking into account key geometries and traffic flows.

PICADY 5 software package was used where priority controlled junctions were to be modelled. PICADY is a junction modelling package used for predicting capacities, queues and delays at priority junctions, taking into account key geometries and traffic flows.

LinSig 3.2.33 was used where signalised junctions were to be modelled, including signalised roundabouts. LinSig is an industry standard junction software package for assessing the design of traffic signal junctions incorporating the impact of junction geometries, traffic flows and the balance of demands and priorities across the junction.

2.3 Time Periods

The model has been developed and validated for the following two-time periods, with 15-minute warm-up and cool-down periods:

- a) AM (08:00 – 09:00); and
- b) PM (17:00 – 18:00).

These time periods align with the local AM and PM peak flow periods, as defined in the Traffic Survey Data Analysis report.

3 Survey Data

3.1 Introduction

The sources of data used in the production of the model are discussed in the Traffic Survey Data Analysis report and summarised briefly in this section. The Traffic Survey Data Analysis is attached in Appendix A.

3.2 Traffic Counts

Table 2 presents the traffic count data used in the development and validation of the ARCADY, PICADY and LinSig models. Classified turning counts for a number of junctions in the study area were provided by Shepway District Council. Additional traffic count data were undertaken by Arcadis in 2017. The peak hours captured were 0800 – 0900 and 1700 – 1800.

Table 2. Summary of Traffic Counts used in Otterpool modelling

Data set	Dates	Locations	Details
Classified turning counts	29 th June 2017	19 sites within the study area	Fully classified turning counts, summarised in 15 minutes time intervals.
Classified turning counts	13 th October 2016	14 sites within the study area	Fully classified turning counts, summarised in 15 minutes time intervals.

4 Signal Data

Signal control specifications and timing plans were obtained from Kent County Council and Highways England for the modelled periods and incorporated into our base models for the setup of the existing signalised junctions. Junction layouts and timing sheets were obtained from Highway England (HE) and Kent County Council (KCC) as shown in Table 3.

Table 3. Signal control plans list

No.	Junction	Source
1	M20 J10	HE
2	M20 J9	KCC
3	A20 Ashford Road / B2067 Otterpool Lane	KCC
4	A259 / Dymchurch Road / Military Road	KCC
5	B2064 Cheriton High Street / B2063 Risborough Lane*	KCC
6	B2064 Cheriton High Street / A2034 Cherry Garden Avenue*	KCC
7	M20 J9	KCC

The full information regarding signal data used for the LinSig modelling can be found in Electronic appendices listed on Appendix B.

5 Signalised Junctions

The list of junctions modelled with LinSig is presented in Table 4 and shown spatially Figure 2.

Table 4. List of signalised junctions

Junction no.	Location
1	M20 J10
9	A20 Ashford Road / B2067 Otterpool Lane
16	A259 / Dymchurch Road / Military Road
24	B2064 Cheriton High Street / B2063 Risborough Lane
25	B2064 Cheriton High Street / A2034 Cherry Garden Avenue
27	M20 J9

Figure 2. Location of signalised junctions

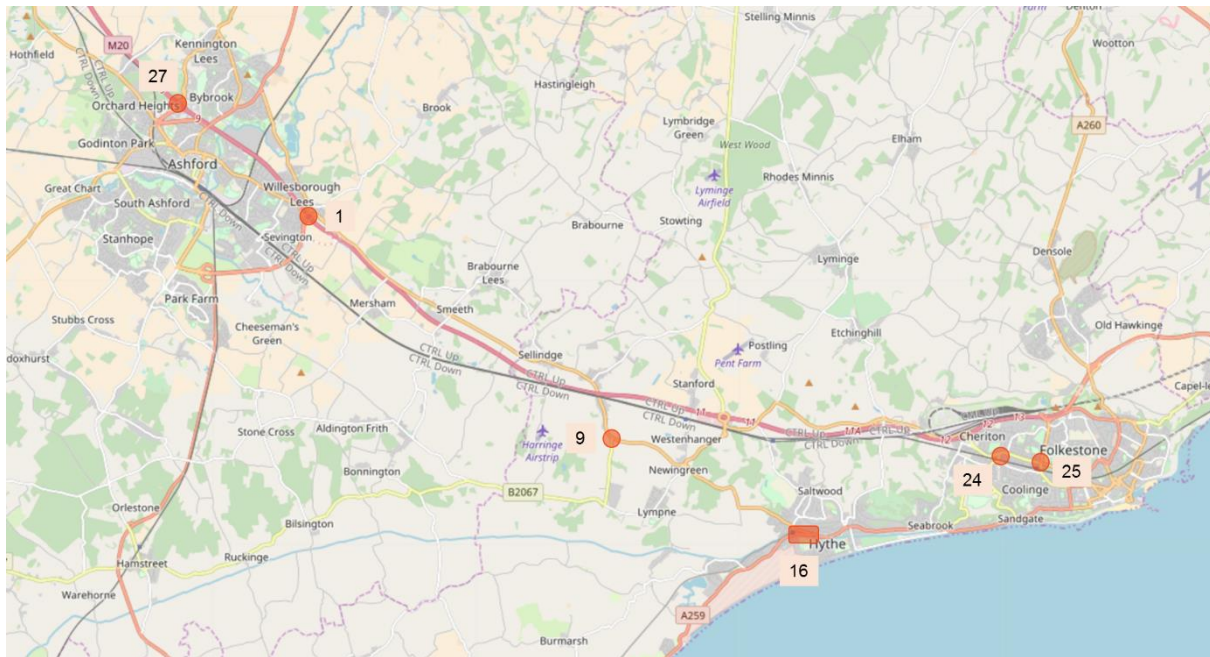

5.1 Junction 1: M20 Junction 10

The M20 Junction 10 is a large seven arm signalised roundabout, located south of William Harvey Hospital in Ashford. The junction entry arms are:

- A292 Hythe Road and M20 eastbound offslip road in the west,
- A2070 Kennington Road and A20 Hythe Road in the north,
- M20 westbound offslip road in the east and
- A2070 Bad Munstereifel Road in the south.

The M20 eastbound onslip road is an exit only arm.

The circulatory carriageway of the roundabout consists of two lanes on A292 Hythe Road approach; of three lanes on M20 eastbound offslip road, M20 westbound offslip road and A2070 Bad Munstereifel Road approaches; and of four lanes on A2070 Kennington Road and A20 approaches.

To the south west of the M20 J10 roundabout, the A292 Hythe Road / M20 westbound onslip road is a signalised junction with three arms.

5.1.1 A292 Hythe Road

A292 Hythe Road arm of the M20 J10 junction has one lane plus a flare lane and the north-eastbound circulatory approach has two lanes. The method of control for the junction is showed in Figure 3

Figure 3. Junction 1 – M20 J10 – A292 Hythe Road arm

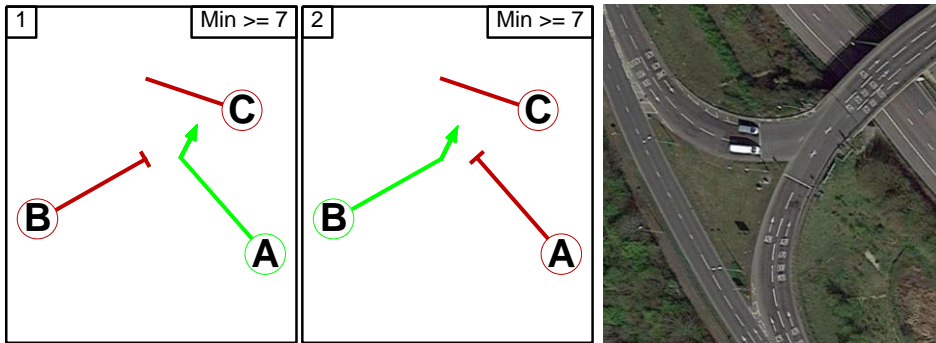

5.1.2 M20 eastbound offslip road

M20 eastbound offslip road arm has two lanes plus a flare lane and the north-eastbound circulatory approach has three lanes. The method of control for the junction is showed in Figure 4.

Figure 4. Junction 1 – M20 J10 – M20 eastbound offslip road arm

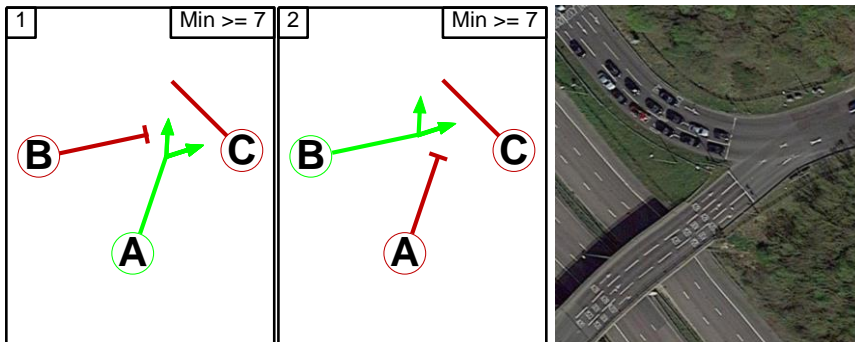

5.1.3 A2070 Kennington Road

A2070 Kennington Road arm has two lanes plus a flare lane and the south-eastbound circulatory approach has four lanes. The method of control for the junction is showed in Figure 5.

Figure 5. Junction 1 – M20 J10 – A2070 Kennington Road arm

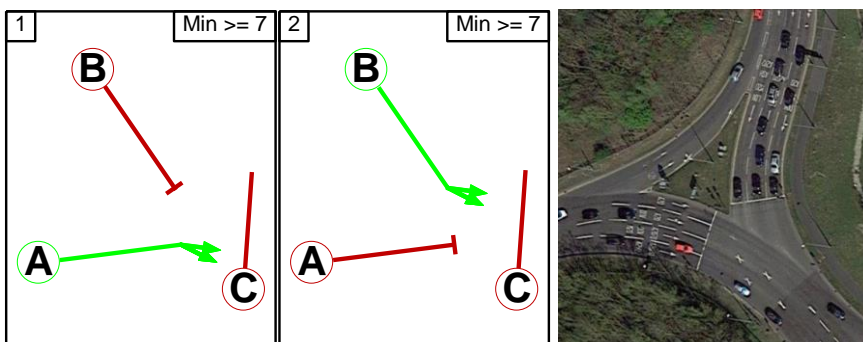

5.1.4 A20 Hythe Road

A20 Hythe Road arm has two lanes plus a flare lane and the south-eastbound circulatory approach has four lanes. A20 Hythe Road entry arm has a signalised pedestrian crossing. A signalised pedestrian crossing is location in the A20 Hythe Road exit arm. The layout of the junction is shown in Figure 6.

Figure 6. A20 Hythe Road arm – M20 J10



The method of control for the junction is shown in Figure 7 and Figure 8.

Figure 7. Junction 1 – M20 J10 – A20 Hythe Road arm. Stream 1

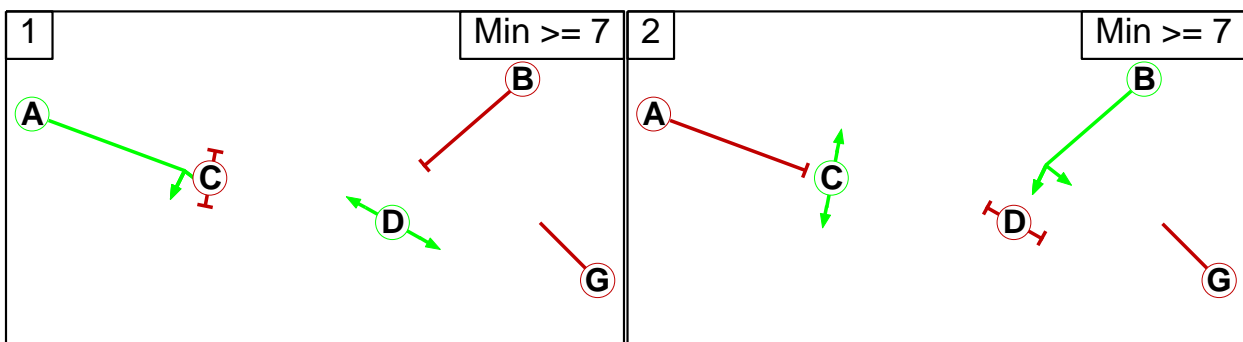
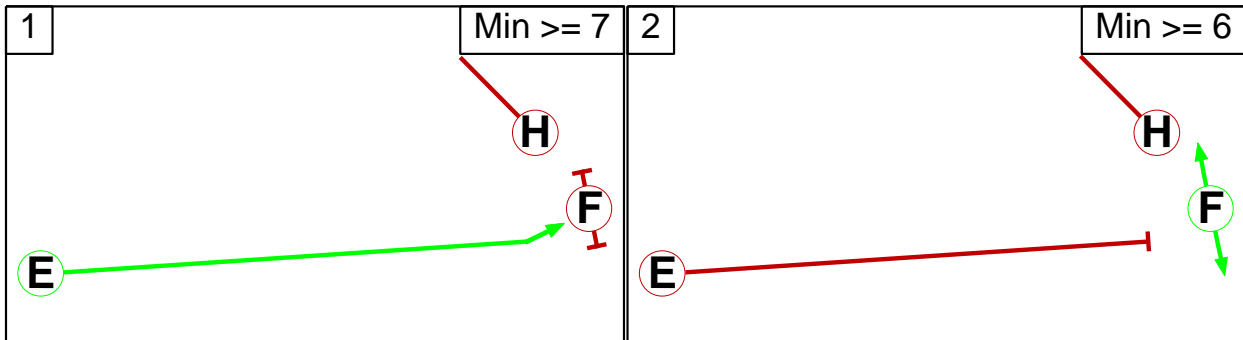

Figure 8. Junction 1 – M20 J10 – A20 Hythe Road exit arm. Stream 2



5.1.5 M20 westbound offslip road

M20 westbound offslip road arm has two lanes plus a flare lane and the south-westbound circulatory approach has three lanes. The method of control for the junction is showed in Figure 9.

Figure 9. Junction 1 – M20 J10 – M20 westbound offslip road arm

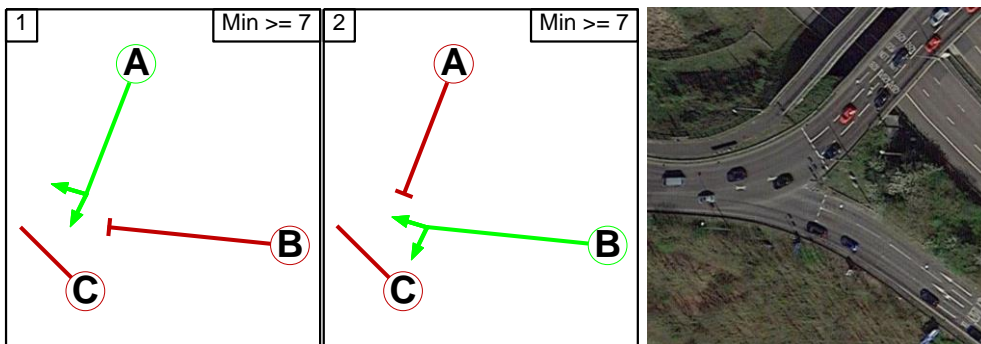

5.1.6 A2070 Bad Munstereifel Road

A2070 Bad Munstereifel Road arm has two lanes plus two flare lanes and the north-westbound circulatory approach has three lanes. A2070 Bad Munstereifel Road entry arm has a signalised pedestrian crossing. A signal controlled pedestrian crossing in the A2070 Bad Munstereifel Road exit arm. The layout of the junction is shown in Figure 10.

Figure 10. A2070 Bad Munstereifel Road arm – M20 J10



The method of control for the junction is shown in Figure 11 and Figure 12.

Figure 11. Junction 1 – M20 J10 – A2070 Bad Munstereifel Road arm. Stream 1

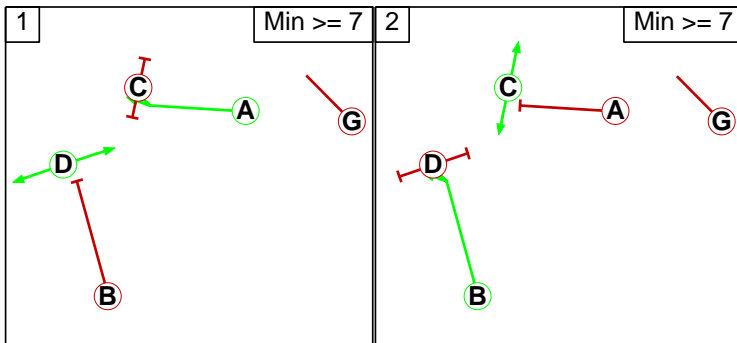
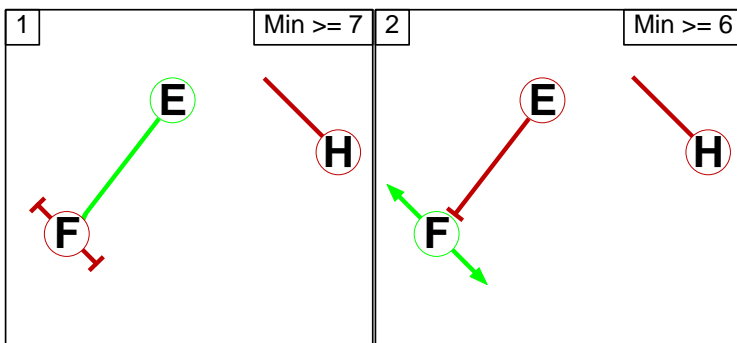

Figure 12. Junction 1 – M20 J10 – A2070 Bad Munstereifel Road exit arm. Stream 2



5.1.7 A292 Hythe Road / M20 westbound onslip road

This is a three arm signalised junction. A292 Hythe Road west arm consists of a two lane for straight ahead traffic and a nearside flare lane for left-turning. A292 Hythe Road east arm consists of one nearside lane for straight ahead traffic and an offside lane for right-turn. M20 westbound onslip road is an exit only arm. A signalised pedestrian crossings is located in the A292 Hythe Road. The layout of the junction is shown in Figure 13.

Figure 13. A292 Hythe Road / M20 westbound onslip road



The existing method of control is shown in Figure 14.

Figure 14. Junction 1 – A292 Hythe Road / M20 westbound onslip road

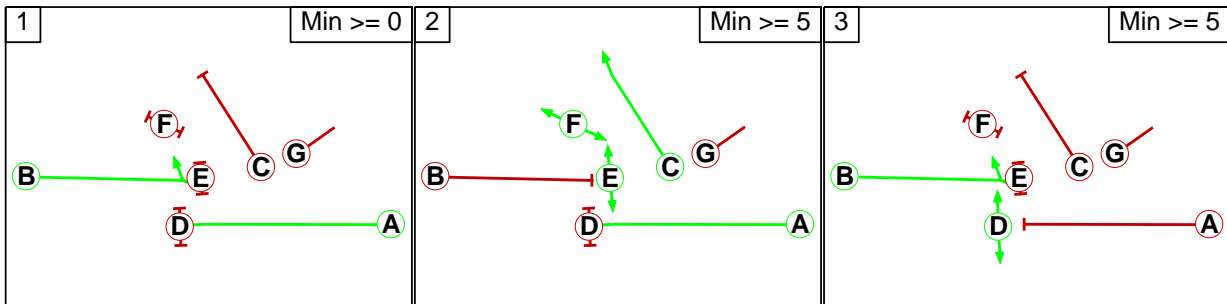

5.2 Junction 9: B2067 Otterpool Lane / A20 Ashford Road

This is a three arm signalised junction located to the north of Lympne Industrial Park and Champneys J Farm (Lympne). B2067 Otterpool Lane approaches the junction from the south and consists of one lane for right- and left-turning traffic. A20 Ashford Road west arm consists of a nearside lane for straight ahead traffic and an offside flare lane for right-turning. A20 Ashford Road east arm consists of a nearside flare lane for left-turning and an offside lane for straight ahead traffic. The layout of the junction is shown in Figure 15.

Figure 15. B2067 Otterpool Lane / A20 Ashford Road



The existing method of control is shown in Figure 16.

Figure 16. Junction 9 – B2067 Otterpool Lane / A20 Ashford Road

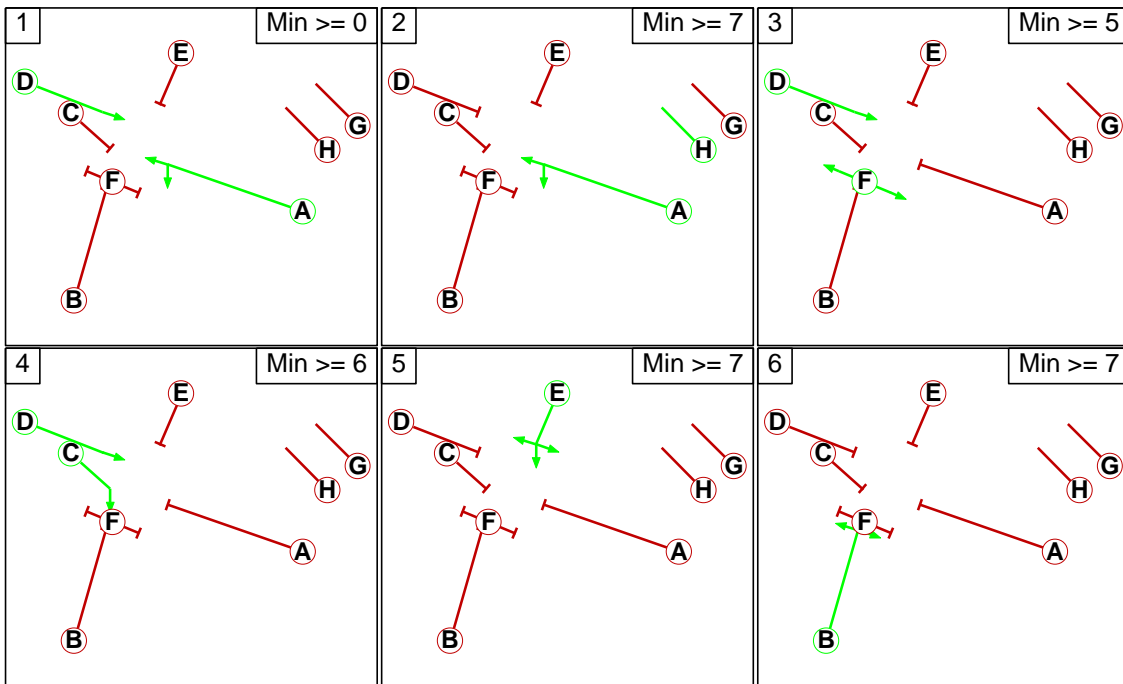

5.3 Junction 16: A259 / Military Road / Dymchurch Road (Hythe)

Junction 16 is a big circulatory junction located east of Hythe railway station. It consists of two signalised junctions, A261 London Road / A259 Scalons Bridge / Military Road / Green Lane and A259 Scalons Bridge / A259 Dymchurch Road, and three signalised pedestrian crossings. Five different controllers have been defined in LinSig, as explained below.

5.3.1 A261 London Road / A259 Scalons Bridge / Military Road / Green Lane

This signalised junction is a four arm junction. A261 London Road in the north consists of an offside lane for straight ahead and right turning traffic. A259 Scalons Bridge in the south consists of two lanes, the nearside one for straight ahead and left turning traffic and an offside lane for right turning traffic. Green Lane in the west consists of one lane for left and right turning and straight ahead traffic. Military Road arm is an exit only arm. The layout of the junction is shown in Figure 17.

Figure 17. A261 London Road / A259 Scalons Bridge / Military Road / Green Lane



The method of control for the junction is shown in Figure 18.

Figure 18. Junction 16 – A261 London Road / A259 Scalons Bridge / Military Road / Green Lane

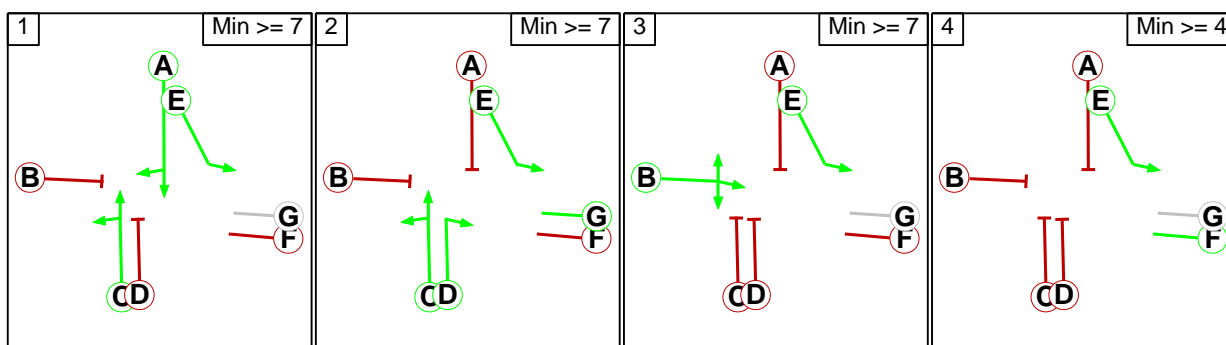

5.3.2 A259 Scalons Bridge / A259 Dymchurch Road

This is a three arm junction. A259 Scalons Bridge in the north consists of one lane for right-turning only. A259 Dymchurch Road east arm consists of two lanes plus an offside flare lane. The nearside lane is for straight ahead traffic, and the middle lane and offside flare lane for right-turning traffic. A259 Dymchurch Road west arm consists of a nearside flare lane and an offside lane for left-turning traffic. Figure 19 presents the layout of the junction.

Figure 19. A259 Scalons Bridge / A259 Dymchurch Road



The method of control for the junction is showed in Figure 20.

Figure 20. Junction 16 – A259 Scalons Bridge / A259 Dymchurch Road

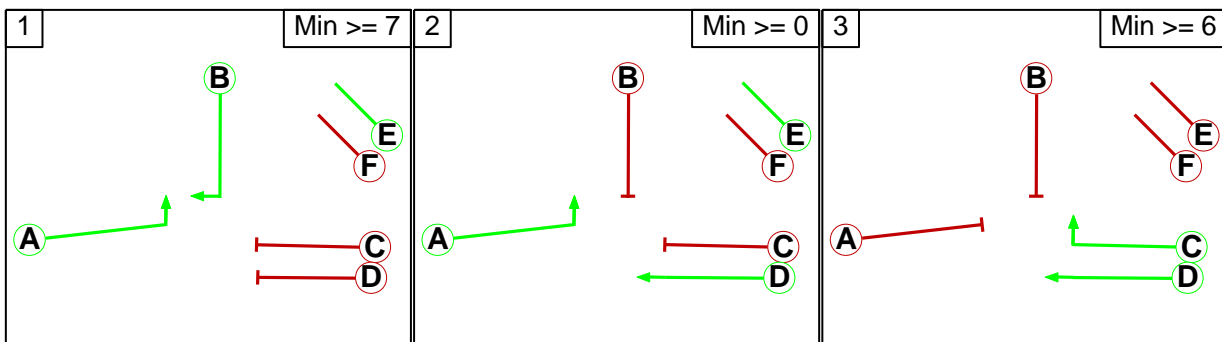

5.3.3 Dymchurch Road pedestrian crossing

A signalised pedestrian crossing is located in Dymchurch Road, east of Portland Road. The method of control for the junction is showed in Figure 21.

Figure 21. Junction 16 – Dymchurch Road pedestrian crossing

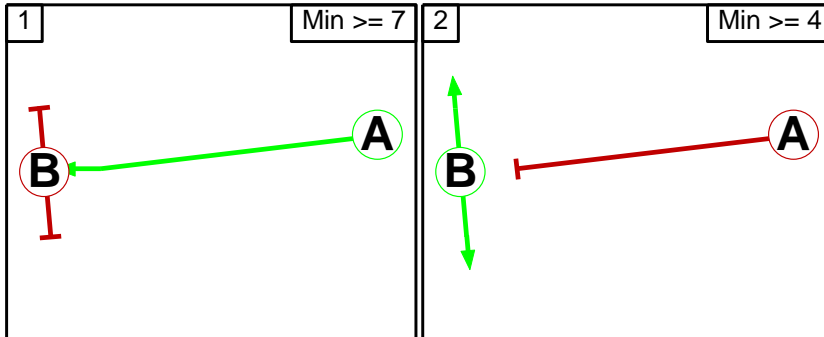

5.3.4 Military Road pedestrian crossing

A signalised pedestrian crossing is located in Military Road, in Sainsbury's entry access. The method of control for the junction is showed in Figure 22.

Figure 22. Junction 16 – Military Road pedestrian crossing

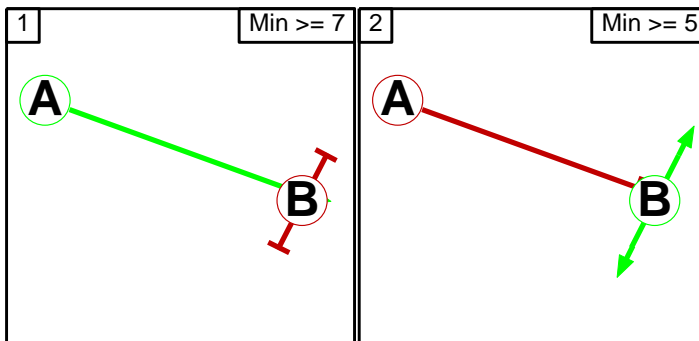

5.3.5 A259 Scalons Bridge pedestrian crossing

A signalised pedestrian crossing is located in A259 Scalons Bridge Road, south of the Royal Military Canal. The method of control for the junction is showed in Figure 23.

Figure 23. Junction 16 – A259 Scalons Bridge pedestrian crossing

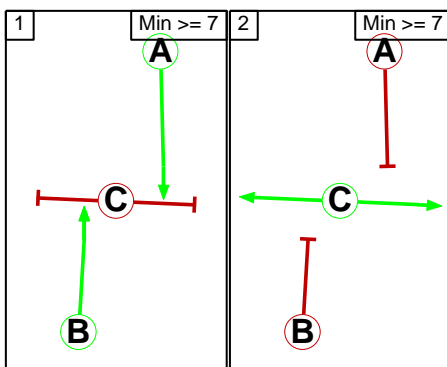

5.4 Junction 24: B2064 Cheriton High Street / B2063 Risborough Lane / Stanley Road

This is a four arm signalised junction located to the south of All Souls Primary School (Folkestone). B2064 Cheriton High Street west arm consists of an offside flare lane for right-turning traffic and a nearside lane for straight ahead traffic. Risborough Lane approaches the junction from the south and consists of a nearside lane for left-turning and an offside flare lane for right-turning traffic. Stanley Road approaches the junction from the north and consists of one lane for left- and right-turning traffic. B2064 Cheriton High Street east arm consists of a nearside flare lane for left-turning traffic and an offside lane for straight ahead traffic. B2064 Cheriton High Street east arm has a signalised pedestrian crossing. Figure 24 presents the layout of this junction.

Figure 24. B2064 Cheriton High Street / B2063 Risborough Lane / Stanley Road



The existing method of control is shown in Figure 25.

Figure 25. Junction 24 – B2064 Cheriton High Street / B2063 Risborough Lane / Stanley Road

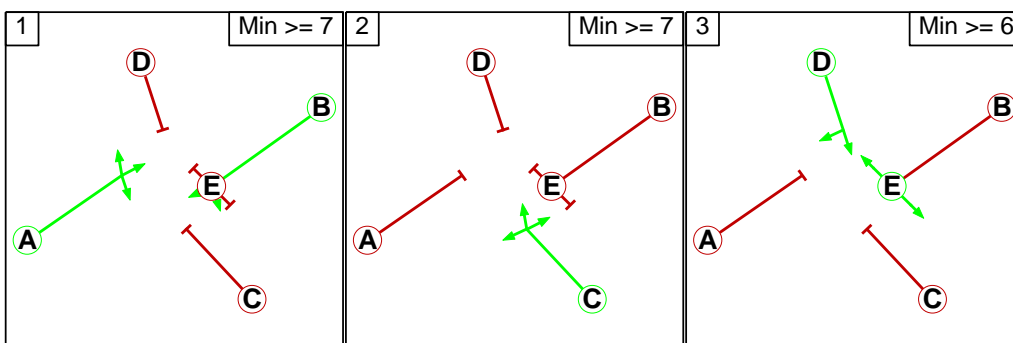

Phasing and staging are consistent with existing timing sheet provided.

5.5 Junction 25: B2064 Cheriton High Street / A2034 Cherry Garden Avenue

This is a four arm signalised junction located to the west of Cheriton Road Cemetery (Folkestone). B2064 Cheriton High Street approaches the junction from the west and consists of a nearside lane for left turning traffic, a middle lane for straight ahead traffic and the offside flare lane for right turning traffic. Cherry Garden Avenue approaches the junction from the north and consists of a nearside lane for left turning traffic, a middle lane for straight ahead traffic and an offside flare lane for right turning traffic. A2034 Cheriton Road approaches the junction from the east and consists of a nearside lane for left turning and straight ahead traffic and an offside flare lane for right turning. Beachborough Road approaches the junction from the south and consists of one lane for left turning, straight ahead and right turning traffic. All arms have signalised pedestrian crossings which operate in an all red stage.

Figure 26. B2064 Cheriton High Street / A2034 Cherry Garden Avenue



The existing method of control is shown in Figure 27.

Figure 27. Junction 25 – B2064 Cheriton High Street / A2034 Cherry Garden Avenue

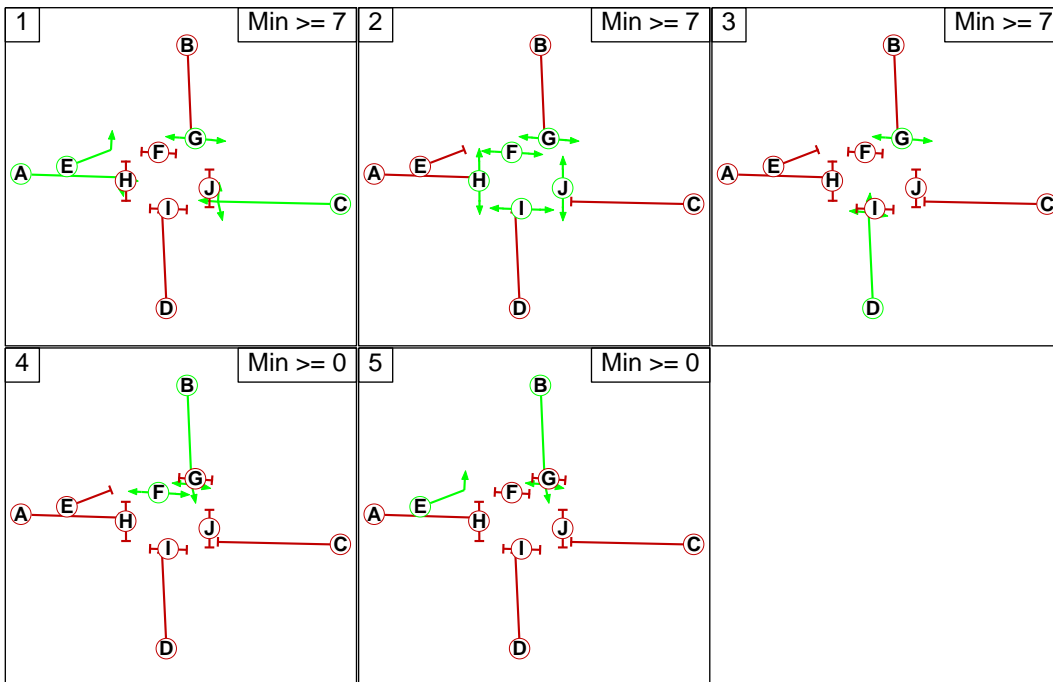

5.6 Junction 27: M20 Junction 9

This is a large six arm signalised roundabout, located east of Kent County Council (Ashford). The junction entry arms are M20 eastbound offslip road in the west, A251 Trinity Road in the north, M20 westbound offslip road in the east and A20 Fougères Way in the south. The M20 eastbound onslip and M20 westbound onslip roads are exit arms only.

The circulatory carriageway of the roundabout consists of three lanes on all the approaches, except in the A251 Trinity Road approach where there's a nearside flare lane towards the M20 eastbound onslip road exit.

5.6.1 M20 eastbound offslip road

M20 eastbound offslip road arm has two lanes plus two flare lanes and the north-eastbound circulatory approach has three lanes. The method of control for the junction is shown in Figure 28.

Figure 28. Junction 27 – M20 J9 – M20 eastbound offslip road arm

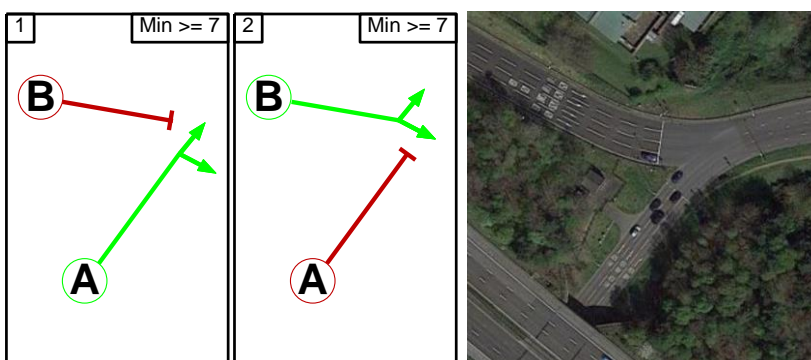

5.6.2 A251 Trinity Road

A251 Trinity Road arm has two lanes plus a flare lane and the south-eastbound has three lanes plus a flare lane. The method of control for the junction is showed in Figure 29.

Figure 29. Junction 27 – M20 J9 – A251 Trinity Road arm

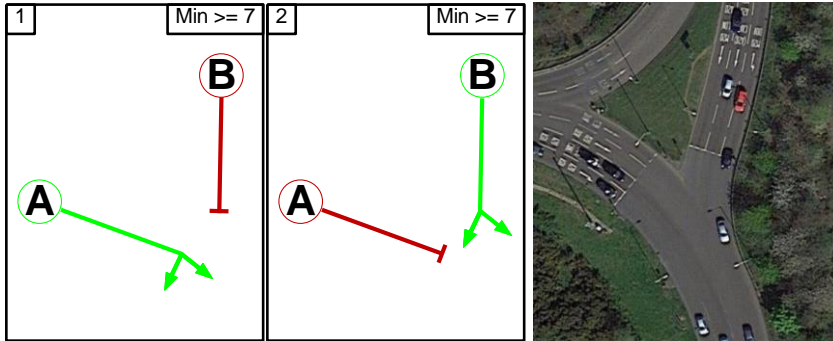

5.6.3 M20 westbound offslip road

M20 westbound offslip road arm has two lanes plus two flare lanes and the south-westbound circulatory approach has three lanes. The method of control for the junction is showed in Figure 30.

Figure 30. Junction 27 – M20 J9 – M20 westbound offslip road arm

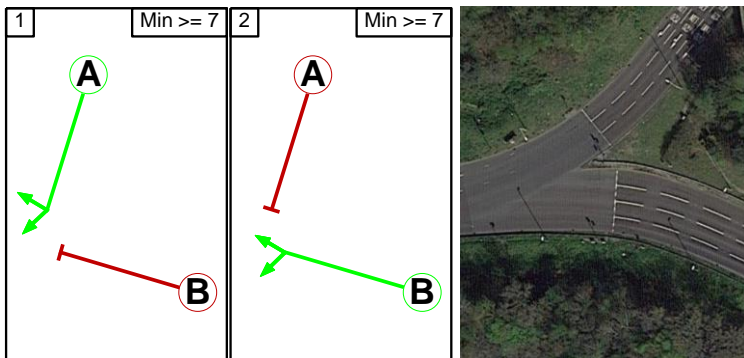

5.6.4 A20 Fougères Way

A20 Fougères Way arm has three lanes plus a flare lane and the north-westbound circulatory approach has three lanes. The method of control for the junction is showed in Figure 31.

Figure 31. Junction 27 – M20 J9 – A20 Fougères Way arm

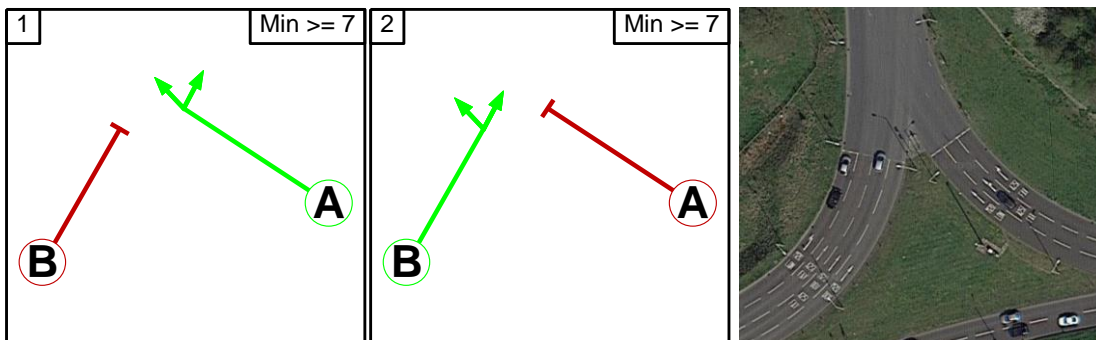

5.7 Modelling assumptions

The following assumptions were made when constructing the base traffic modelling scenarios:

- a) Intergreen times, method of control, phase minimums and phase delays were taken from the controller specifications provided by Kent County Council and Highways England.
- b) Cycle times for each peak period were measured through the footage included as part of the traffic surveys. Only junction number 9 (A20 Ashford Road / B2067 Otterpool Lane) did not have video recordings available, hence, the cycle times were obtained from the controller specifications.
- c) Saturation flows were measured on all major links where possible and readings were inputted directly into LinSig. Where this was not possible, the formula outlined within TfL Research Report 67 (RR67) was used to calculate the remaining saturation flows. These were then altered as weighted saturation flows based on difference between RR67 and observed values in the most similar junction approach with available footage. On average, the adjustment factor varied between 0.91 - 0.95 to ensure the correctly representation of site conditions.
- d) The effective flare lane lengths, flare usage, link and lane lengths were obtained from the available footage and drawings provided along with controller specifications and OS mapping base plans of the area.
- e) Mean cruise speeds were assumed to be 35 km/h on staggered, crossing and T-junctions, whereas 45 km/h was used for Roundabouts.
- f) The model peak period used for this model is consistent with the network peak period (0800 – 0900 and 1700 – 1800).

5.8 Model results

The results of the modelling analysis are contained in Table 5 and refer to the degree of saturation of the junction, which is taken as the degree of saturation of the worst performing link of the junction. The full model outputs can be found in Electronic appendices listed on Appendix C.

Table 5. Degree of saturation values for signalised junctions

Junction	Location	AM	PM
1	M20 J10	91.6%	97.2%
9	A20 Ashford Road / B2067 Otterpool Lane	50.3%	50.5%
16	A259 / Dymchurch Road / Military Road	85.5%	90.7%
24	B2064 Cheriton High Street / B2063 Risborough Lane	85.6%	87.2%
25	B2064 Cheriton High Street / A2034 Cherry Garden Avenue	91.0%	94.1%
27	M20 J9	88.7%	92.6%

Links with a degree of saturation of more than 90% are considered to be operating over design capacity. Links that operate above 100% are over capacity and subsequently traffic is likely to experience long delays. Results from Table 5 show that links in some of the junctions there are operating over design capacity, as M20 Junction 10 and junction 25 B2064 Cheriton High Street / A2034 Cherry Garden Avenue in the AM and PM peaks and junctions 16 A259 / Dymchurch Road / Military Road and M20 J9 in the PM peak. On the other hand, Junction 9 A20 Ashford Road / B2067 Otterpool Lane and junction 24 B2064 Cheriton High Street / B2063 Risborough Lane operate within capacity in both peak hours.

6 Priority Controlled Roundabouts

6.1 Junction description

The list of priority-controlled roundabouts is presented in Table 6 and is presented spatially in Figure 33.

Table 6. List of priority-controlled roundabouts

No.	Junction
2	M20 J11
8	Hythe Road (A20) / The Street
20	A259 Prospect Road / A259 Seabrook Road / Station Road / High Street
21	M20 J11A
22	M20 J12
23	M20 J13
28	A260 Spitfire Way / White Horse Hill / A20 Slip Roads
29	Alkham Valley Road / A20 slip roads

Figure 32. Location of priority controlled roundabouts

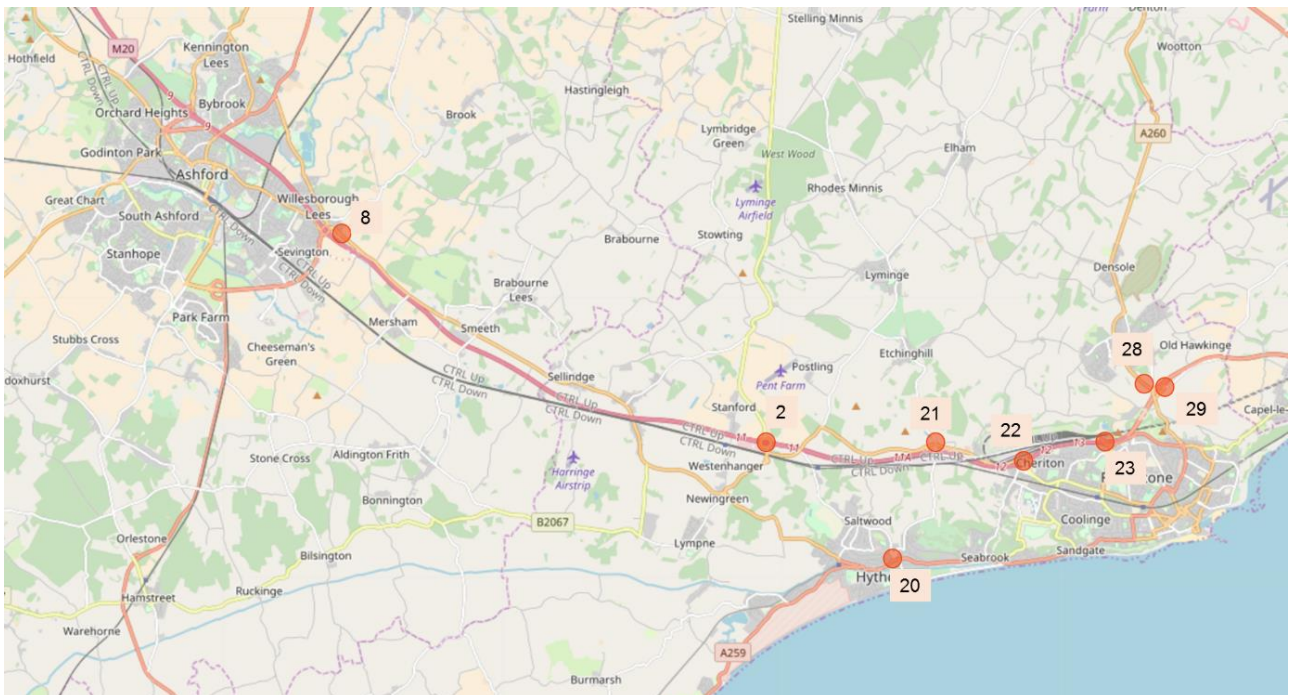

6.2 Junction 2: M20 Junction 11

The M20 Junction 11 is a large seven arm roundabout, located east of Westenhanger (Shepway). The junction entry arms are

- a) B2068 in the north which consists of one nearside flare lane and an offside lane,
- b) M20 westbound offslip road in the east which consists of two lanes,
- c) A20 Ashford Road and Channel Ports in the south, which consists of two and one lane respectively, and
- d) M20 eastbound offslip road in the west which consists of two lanes.

The M20 eastbound and M20 westbound onslip roads are exit only arms. The circulatory carriageway of the roundabout consists of two lanes on all the approaches. The junction layout is shown in Figure 33.

Figure 33. M20 J11

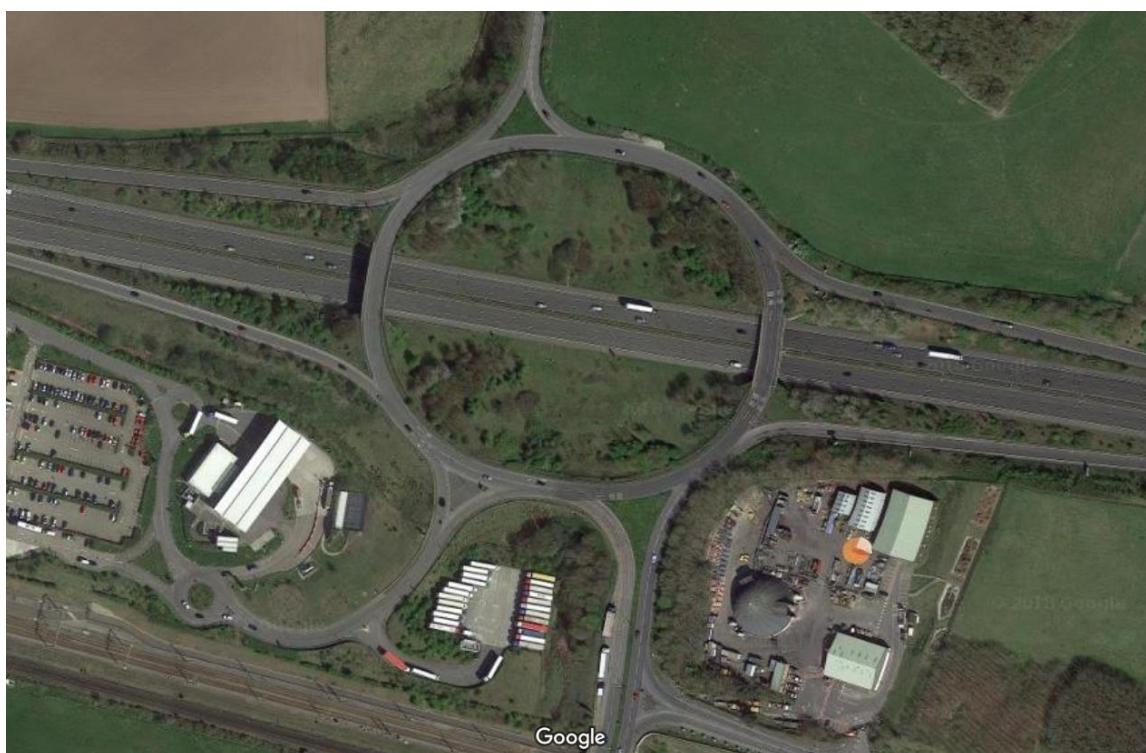

6.3 Junction 8: A20 Hythe Road / The Street

The A20 Hythe Road / The Street junction is a four arm roundabout located east of M20 J10 roundabout. The junction arms are

- a) The Street in the north which consists of one lane,
- b) A20 Hythe Road in the east which consists of one lane,
- c) Tesco road access in the south which consists of one lane; and
- d) A20 Hythe Road in the west which consists of an offside lane and a nearside flare lane.

The circulatory carriageway of the roundabout consists of one lane on all the approaches. The layout of the junction is shown in Figure 34.

Figure 34. A20 Hythe Road / The Street



6.4 Junction 20: A259 Prospect Road / A259 Seabrook Road / Station Road / High Street (Hythe)

The A259 Prospect Road / A259 Seabrook Road / Station Road / High Street junction is a four arm roundabout located west of Hythe United Reformed Church. The junction arms are:

- a) Station Road in the north,
- b) A259 Seabrook Road in the east,
- c) A259 Prospect Road in the south and
- d) Hythe High Street in the west.

Hythe High Street is an exit arm only. All the arms consists of one lane, except A259 Prospect Road which has a lane used by buses. The circulatory carriageway of the roundabout consists of one lane on all the approaches. Figure 35 presents the junction layout.

Figure 35. A259 Prospect Road / A259 Seabrook Road / Station Road / High Street (Hythe)



6.5 Junction 21: M20 J11A

The M20 J11A is a four arm roundabout located west of the Eurotunnel access. The junction arms are:

- a) Beachborough in the north,
- b) A20 Ashford Road in the east,
- c) Bargrove in the south and
- d) A20 Ashford Road in the west.

All the arms consists of one lane, except A20 Ashford Road west arm which has a flare lane. The circulatory carriageway of the roundabout consists of one lane on all the approaches. The junction layout is shown in Figure 36.

Figure 36. M20 J11A



6.6 Junction 22: M20 Junction 12

The M20 Junction 12 is a large six arm roundabout, located south of the Eurotunnel access. The junction entry arms are:

- a) M20 westbound offslip road in the east which consists of two lanes,
- b) B2064 Cheriton Approach in the south which consists of two lanes,
- c) M20 eastbound offslip road and
- d) A20 Ashford Road in the west which consists of two lanes both.

The M20 eastbound and M20 westbound onslip roads are exit only arms. The circulatory carriageway of the roundabout consists of two lanes on the M20 eastbound offslip road and A20 Ashford Road approaches, and of one lane on the M20 westbound offslip road and B2064 Cheriton approaches. The junction layout is shown in Figure 37.

Figure 37. M20 J12



6.7 Junction 23: M20 Junction 13

This junction has been split into two different ARCADY models, one model for M20 eastbound slip roads / A20 Castle Hill Bridge roundabout; and a second model for M20 westbound slip roads / A259 Churchill Avenue / A2034 Cherry Garden Avenue roundabout.

6.7.1 M20 eastbound slip roads / A20 Castle Hill Bridge

This is a four arm roundabout, located in the north of M20. Castle Hill arm in the north consists of one lane. A20 Castle Bridge arm in the south consists of one lane. M20 eastbound offslip road in the west consists of two lanes. M20 eastbound onslip road is an exit only arm. The circulatory carriageway of the roundabout consists of two lanes on all the approaches. The junction layout is shown in

Figure 38. M20 eastbound slip roads / A20 Castle Hill Bridge



6.7.2 M20 westbound slip roads / A259 Churchill Avenue / A2034 Cherry Garden Avenue

This is a five arm roundabout, located in the south of M20. M20 westbound offslip road in the north consists of two lanes. A259 Churchill Avenue in the east consists of two lanes plus a nearside flare lane. A2034 Cherry Garden Avenue in the south consists of one lane plus a flare lane. A20 Castle Bridge in the west consists of two lanes. M20 westbound onslip road is an exit only arm.

The circulatory carriageway of the roundabout consists of two lanes on all the approaches as shown in Figure 39.

Figure 39. M20 westbound slip roads / A259 Churchill Avenue / A2034 Cherry Garden Avenue

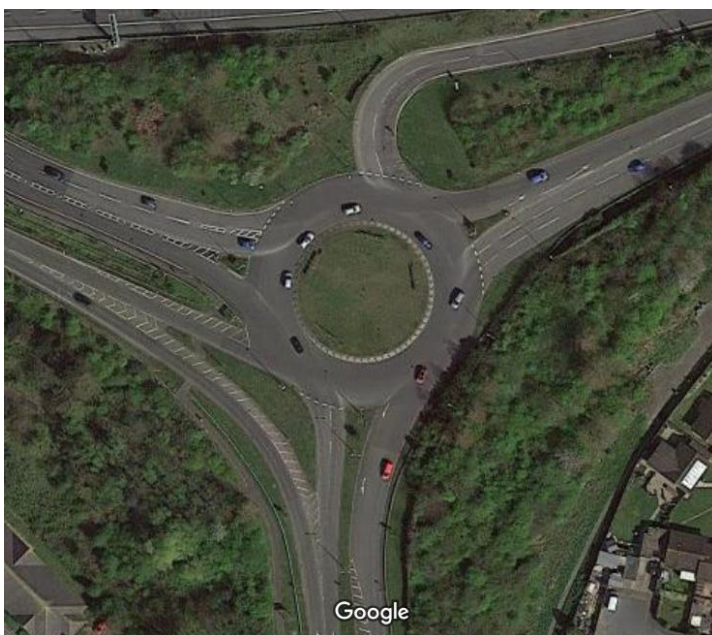

6.8 Junction 28: A260 Spitfire Way / White Horse Hill / A20 Slip Roads

This is a five arm roundabout located south of Hawkinge. The junction entry arms are:

- a) White Horse Hill in the north,
- b) A20 eastbound offslip road in the east,
- c) A260 Canterbury Road in the south and
- d) A260 Spitfire Way in the west.

All entry arms consist of one lane plus a flare lane. A20 eastbound onslip road in the east is an exit only arm.

The circulatory carriageway of the roundabout consists of two lanes on all the approaches. The junction layout is shown in Figure 40.

Figure 40. A260 Spitfire Way / White Horse Hill / A20 Slip Roads

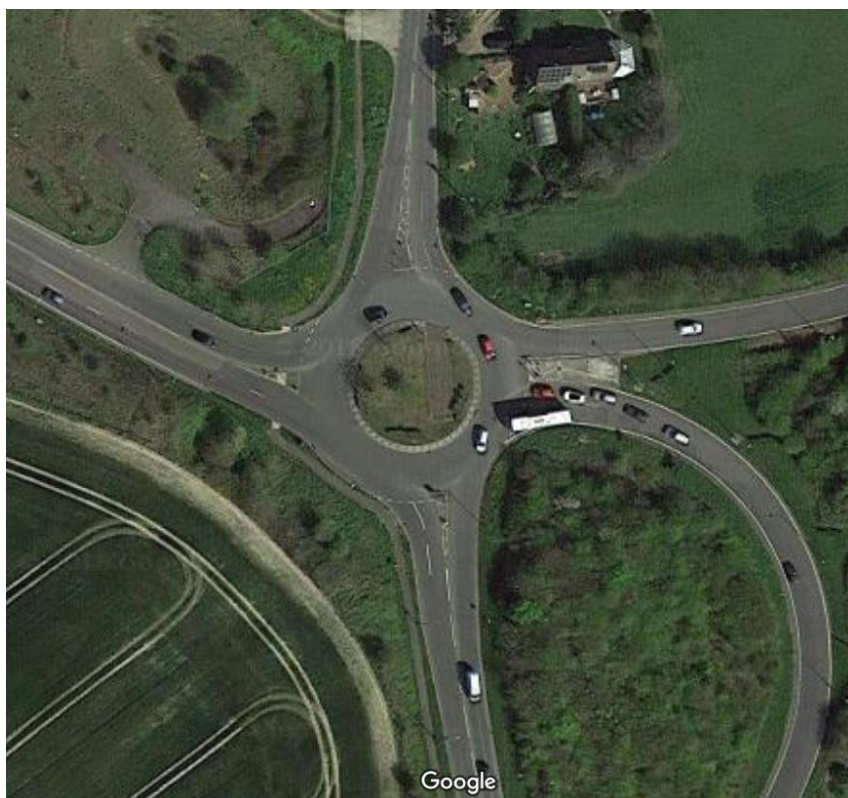

6.9 Junction 29: Alkham Valley Road / A20 Slip Roads

This is a four arm roundabout located . The junction entry arms are:

- a) A20 eastbound offslip road in the north,
- b) Alkham Valley Road in the east and
- c) Alkham Valley Road in the south.

All entry arms consists of one lane plus a flare lane A20 westbound onslip road is an exit only arm. The circulatory carriageway of the roundabout consists of two lanes on all the approaches, as shown in Figure 41.

Figure 41. Alkham Valley Road / A20 Slip Roads

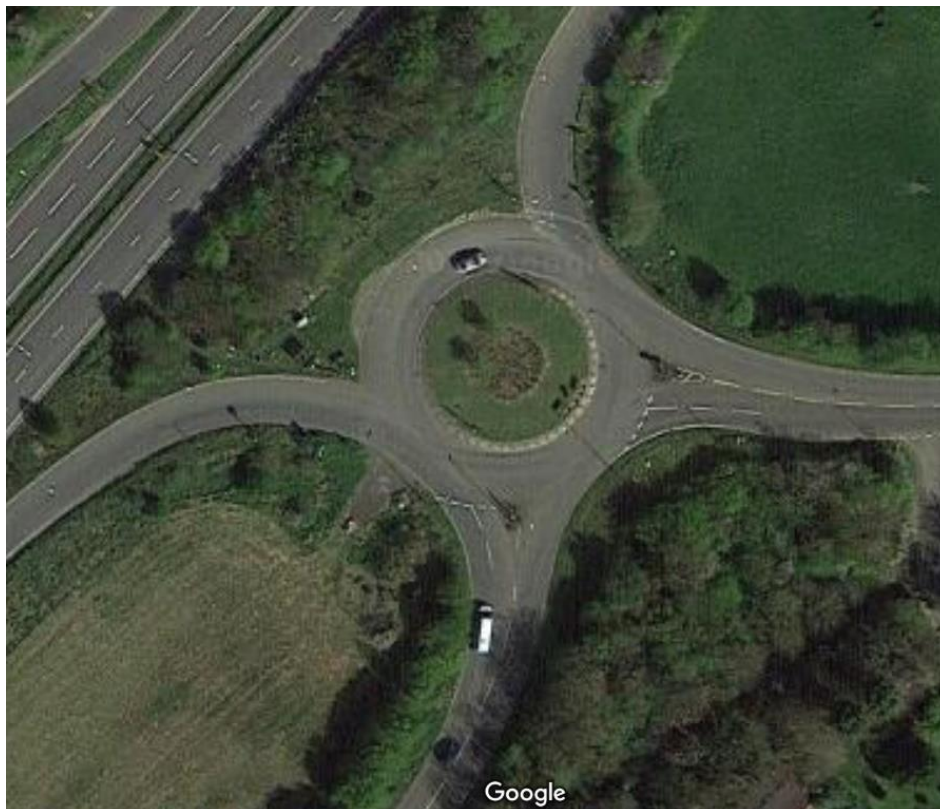

6.10 Modelling assumptions

The following assumptions were made when constructing the base traffic modelling scenarios:

- a) The model peak period used for this model is consistent with the network peak period (0800 – 0900 and 1700 – 1800).
- b) Based on the type of flow data available, traffic demand data was entered as ODTAB – synthesised from a peak hour turning-traffic counts.
- c) Heavy vehicle data was set up to vary over turning movement and inputted accordingly. The individual values for each turning movement were obtained from traffic survey data.
- d) Geometric parameters were attained from drawings provided by Kent County Council and Highways England.

6.11 Model results

The summarised results of the analysis are contained in Table 7 which refer to the Ratio of Flow to Capacity (RFC) of the junctions which is taken as the ratio of the flow to capacity on the worst performing arm of the junction. The full model outputs can be found in Electronic appendices listed on Appendix D.

RFC values are an indication of the amount of available capacity which is being used on the worst performing arm of the junction. An RFC value of 1 or higher would indicate that the junction is overcapacity on at least the worst performing arm.

The modelling results show that all junctions work within capacity at the exception of Alkham Valley Road / A20 slip road junction which performs with a maximum RFC of 0.740 during the AM peak period.

Otterpool Park
Operational Modelling Validation Report

Table 7. RFC Values for Priority Controlled Roundabouts

Junction	Location	AM	PM
2	M20 J11	0.397	0.449
8	Hythe Road (A20) / The Street	0.676	0.565
20	A259 Prospect Road / A259 Seabrook Road / Station Road / High Street	0.689	0.718
21	M20 J11A	0.281	0.319
22	M20 J12	0.549	0.466
23	M20 J13	0.479	0.510
28	M20 J13 Churchill Ave	0.614	0.569
29	A260 Spitfire Way / White Horse Hill / A20 Slip Roads	0.698	0.734
2	Alkham Valley Road / A20 slip roads	0.740	0.658

7 Priority Controlled Junctions

7.1 Junction description

The list of priority-controlled junctions is presented in Table 8 and shown spatially in Figure 42.

Table 8. List of priority-controlled junctions

No.	Junction
3	Ashford Road (A20) / Swan Lane
4	Ashford Road (A20) / Stone Hill
5	Ashford Road (A20) / Station Road / Church Road
6	Hythe Road (A20) / Mersham
7	A2070 Kennington Road / The Street
10	B2067 Otterpool Lane / Aldington Road
11	Aldington Road / Stone Street
12	A20 Ashford Road / A261 Hythe Road / Stone Street
13	Aldington Road / Lympne Hill
14	A261 Hythe Road / Aldington Road
15	A261 London Road / Barrack Hill
17	A20 Ashford Road / A20 J11 offslip
18	Ashford Road (A20) / Sandling Road
19	A20 Ashford Road / Stone Street
26	A259 Prospect Road / Stade Street
30	A260 Canterbury Road / Alkham Valley Road

Figure 42. Location of priority-controlled junctions

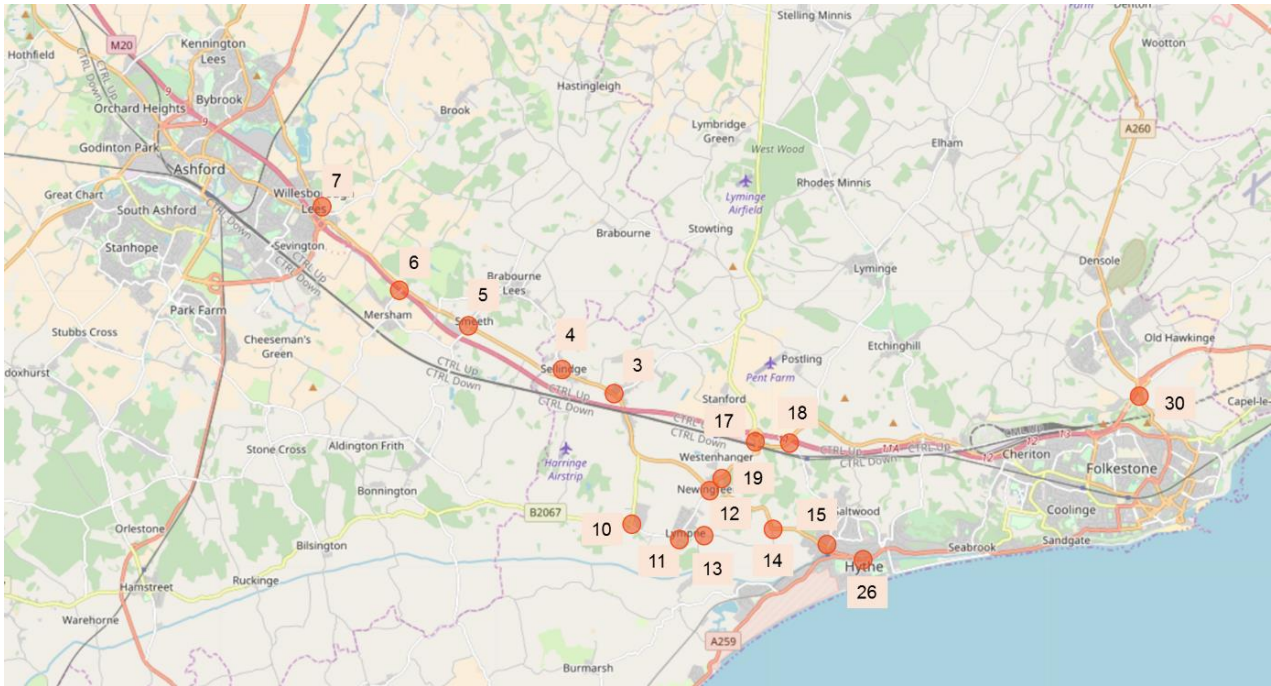

7.2 Junction 3: A20 Ashford Road / Swan Lane

This is a four arm priority junction, located south west of Sellinge. The junction arms are:

- Swan Lane in the north east,
- A20 Ashford Road in the east and
- west arms and a private access in the south west.

All entry arms consist of one lane for left and right turning and straight ahead traffic. Vehicles in Swan Lane and in the private access give way to vehicles in A20 Ashford Road.

Figure 43. A20 Ashford Road / Swan Lane



7.3 Junction 4: A20 Ashford Road / Stone Hill

This is a three arm priority junction, located north of St. Mary the Virgin Church (Sellinge). Stone Hill in the north consists of one lane for straight ahead and left and right turning traffic and A20 Ashford Road east arm consists of one lane for right turning and straight ahead traffic. A20 Ashford Road west arm consists of one lane for left turning and straight ahead traffic. Vehicles in Stone Hill give way to vehicles in A20 Ashford Road. The junction layout is shown in Figure 44.

Figure 44. A20 Ashford Road / Stone Hill



7.4 Junction 5: A20 Ashford Road / Station Road / Church Road

This is a four arm junction. The arms are:

- a) Church Road in the north consists of one lane for right- and left-turning and straight ahead traffic.
- b) A20 Hythe Road east arm consists of a nearside lane for straight ahead and left turning traffic and an offside flare lane for right turning traffic.
- c) A20 Hythe Road west arm consists of a nearside lane for straight ahead and left turning traffic and an offside flare lane for right turning traffic.
- d) Station Road in the south consists of one lane for straight ahead, right and left turning traffic.

Vehicles in Station Road and Church Road give way to vehicles in A20 Ashford Road. The junction layout is shown in Figure 45.

Figure 45. A20 Ashford Road / Station Road / Church Road



7.5 Junction 6: A20 Hythe Road / Mersham

This is a three arm priority junction located north of Mersham:

- A20 Hythe Road in the east consist of a nearside flare lane for right turning traffic and an offside lane for straight ahead traffic.
- The Street (Mersham) in the south consists of a one lane for right and left turning traffic.
- A20 Hythe Road in the west consists of a nearside lane for straight ahead traffic and an offside flare lane for right turning traffic.

Vehicles in Mersham give way to vehicles in A20 Ashford Road. Figure 46 presents the layout of the junction.

Figure 46. A20 Hythe Road / Mersham

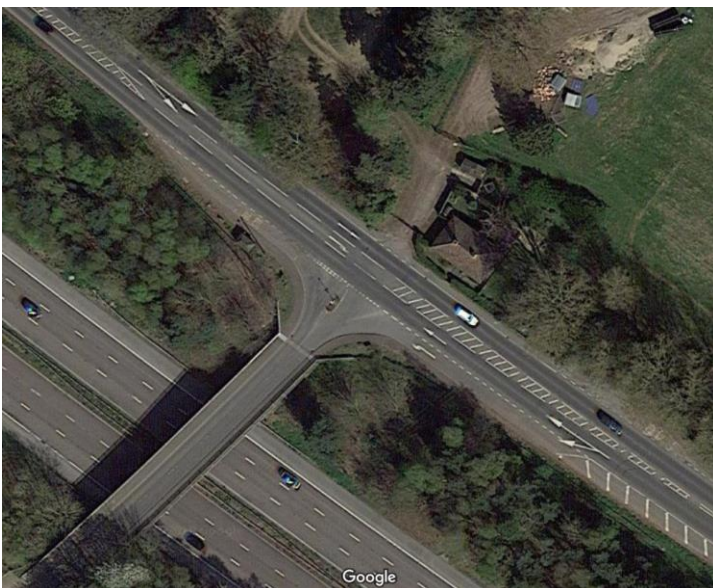

7.6 Junction 7: A2070 Kennington Road / The Street

This is a four arm junction located south of William Harvey Hospital (Ashford):

- a) A2070 Kennington Road north arm consists of a nearside lane for left turning and straight ahead traffic and an offside flare lane for right turning traffic.
- b) The Street east arm consists of an offside lane for right turning and a nearside short flare lane for left turning.
- c) A2070 Kennington Road south arms consists of a nearside lane for left turning and straight ahead traffic and an offside flare lane for right turning traffic.
- d) The Street west arm consists of one lane for right and left turning traffic. Vehicles in The Street give way to vehicles in A2070 Kennington Road.

Figure 47 presents the junction layout.

Figure 47. A2070 Kennington Road / The Street



7.7 Junction 10: B2067 Otterpool Lane / Aldington Road

This is a three arm junction located south of Lympe Industrial Park:

- a) B2067 Otterpool Lane in the north consists of one lane for right turning traffic plus a short flare lane for left turning traffic.
- b) Aldington Road in the east consists of one lane for straight ahead and right turning traffic.
- c) B2067 Aldington Road in the west consists of one lane for straight ahead and left turning traffic.

Vehicles in B2067 Otterpool Lane give way to vehicles in Aldington Road. Figure 48 presents the junction layout.

Figure 48. B2067 Otterpool Lane / Aldington Road



7.8 Junction 11: Aldington Road / Stone Street

This is a three arm junction located south of Lympe.

- a) Stone Street in the north consists of one lane for right turning traffic plus a short flare lane for left turning traffic.
- b) Aldington Road east arm consists of one lane for straight ahead and right turning traffic.
- c) Aldington Road west arm consists of one lane for straight ahead and left turning traffic.

Vehicles in Stone Street give way to vehicles in Aldington Road. The junction layout is shown in Figure 49.

Figure 49. Aldington Road / Stone Street

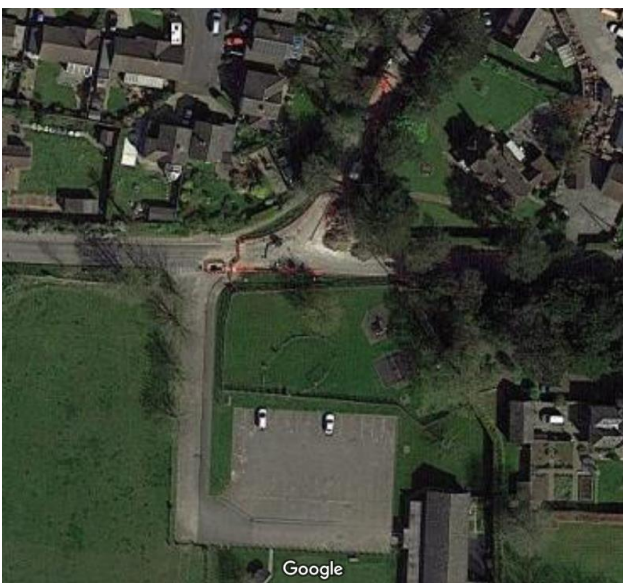

7.9 Junction 12: A20 Ashford Road / A261 Hythe Road / Stone Street

This is a four arm junction located south of Westenhanger:

- a) A20 Ashford Road north arms consists of a nearside flare lane for right-turning traffic and an offside lane for straight ahead traffic to A20 Ashford Road westbound and Stone Street.
- b) A261 Hythe Road in the east consists of one lane for right-turning traffic plus a nearside short flare lane for straight ahead traffic.
- c) Stone Street in the south consists of one lane for right-turning traffic and a nearside short flare lane for left-turning traffic.
- d) A20 Ashford Road west arm consists of a nearside lane for straight ahead traffic and an offside flare lane for left and right turning traffic.

Vehicles in A261 Hythe Road and Stone Street give way to vehicles in A20 Ashford Road. Figure 50 shows the junction layout.

Figure 50. A20 Ashford Road / A261 Hythe Road / Stone Street



7.10 Junction 13: Aldington Road / Lymgne Hill

This is a three arm junction located east of Lymgne:

- a) Aldington Road in the east consists of one lane for left turning and straight ahead traffic.
- b) Lymgne Hill in the south consists of one lane for right turning traffic plus a short flare lane for left turning traffic.
- c) Aldington Road west arm consists of one lane for right turning and straight ahead traffic.

Vehicles in Lymgne Hill give way to vehicles in Aldington Road. Figure 51 presents the junction layout.

Figure 51. Aldington Road / Lympne Hill



7.11 Junction 14: A261 Hythe Road / Aldington Road

This is a three arm junction located south of Pedlinge:

- a) A261 Hythe Road north arm consists of one lane for right turning and straight ahead traffic.
- b) A261 Hythe Road east arm consist of one lane for left turning and straight ahead traffic.
- c) Aldington Road in the south consists of two arms, the west arm is for left turning traffic only and the east arm is for right turning traffic only.

Vehicles in Aldington Road give way to vehicles in A261 Hythe Road. And vehicles turning left from A261 Hythe Road east arm must give way to vehicles turning right from A261 Hythe Road north arm. Figure 52 presents the layout of the junction.

Figure 52. A261 Hythe Road / Aldington Road



7.12 Junction 15: A261 London Road / Barrack Hill

This is a three arm junction located north of the Royal Military Canal (Hythe):

- a) Barrack Hill in the north east consists of one lane for right and left turning traffic.
- b) A261 London Road in the east consists of a nearside lane for straight ahead traffic and an offside flare lane for right turning traffic.
- c) A261 London Road in the west consists of one lane for left turning and straight ahead traffic.

Vehicles in Barrack Hill give way to vehicles in A261 London Road. The junction layout is shown in Figure 53.

Figure 53. A261 London Road / Barrack Hill



7.13 Junction 17: A20 Ashford Road / A20 Junction 11 offslip

This is a three arm junction located south of M20 Junction 11:

- a) A20 Ashford Road north arm consists of a nearside lane for left turning traffic and an offside lane for straight ahead traffic.
- b) A20 Ashford Road east arm consists of one lane for left turning traffic only.
- c) A20 Ashford Road south arm consists of two lanes for straight ahead traffic.

Vehicles in A20 Ashford Road east arm give way to vehicles in A20 Ashford Road north arm. Figure 54 presents the junction layout.

Figure 54. A20 Ashford Road / A20 J11 offslip



7.14 Junction 18: A20 Ashford Road / Sandling Road

This is a three arm junction located north west of Sandling railway station:

- a) A20 Ashford Road east arm consists of one lane for left turning and straight ahead traffic.
- b) Sandling Road in the south east consists of one lane for right turning traffic and a short flare lane for left turning traffic.
- c) A20 Ashford Road west arm consists of one lane for straight ahead and right turning traffic.

Vehicles from Sandling Road arm give way to vehicles in A20 Ashford Road. Figure 55 presents the junction layout.

Figure 55. A20 Ashford Road / Sandling Road

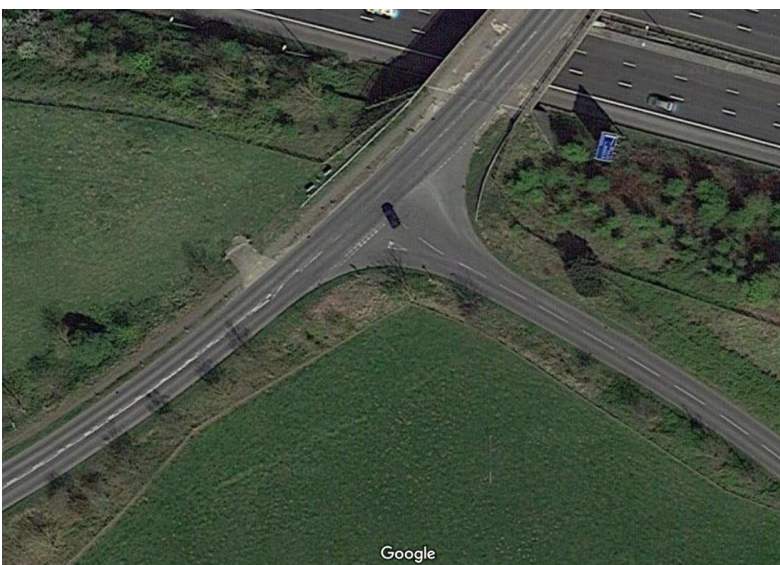

7.15 Junction 19: A20 Ashford Road / Stone Street

This is a three arm junction located south of Westenhanger:

- a) Stone Street in the north consists of one lane for right and left turning traffic.
- b) A20 Ashford Road east arm consists of one lane for straight ahead and right turning traffic.
- c) A20 Ashford Road west arm consists of one lane for left turning and straight ahead traffic.

Vehicles in Stone Street give way to vehicles in A20 Ashford Road. The junction layout is shown in Figure 56.

Figure 56. A20 Ashford Road / Stone Street



7.16 Junction 26: A259 Prospect Road / Stade Street

This is a three arm junction located north of the Oaklands Health Centre (Hythe):

- a) A259 Prospect Road in the east consists of one lane for left turning and straight ahead traffic.
- b) Stade Street in the south consists of one lane for right turning traffic plus a short flare lane for left turning traffic.
- c) A259 Rampart Road in the west consists of a nearside lane for straight ahead traffic and an offside flare lane for right turning traffic.

Vehicles in Stade Street give way to vehicles in A259. Figure 57 presents the junction layout.

Figure 57. A259 Prospect Road / Stade Street



7.17 Junction 30: A260 Canterbury Road / Alkham Valley Road

This is a three arm junction, located south of A260 Canterbury Road overbridge:

- a) A260 Canterbury Road in the north consists of one lane for left turning and straight ahead traffic.
- b) Alkham Valley Road in the east consists of one nearside flare lane for left turning traffic and an offside lane for right turning.
- c) A260 Canterbury Road south arm consists of a nearside lane for straight ahead traffic and an offside lane for right turning traffic.

Vehicles in Alkham Valley Road give way to vehicles in A260 Canterbury Road. The layout of the junction is presented in Figure 58.

Figure 58. A260 Canterbury Road / Alkham Valley Road

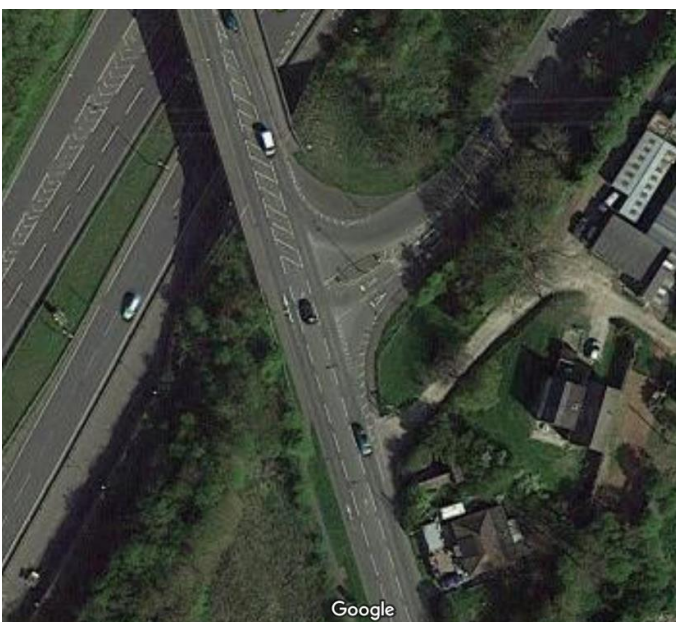

7.18 Modelling assumptions

The following assumptions were made when constructing the base traffic modelling scenarios:

- a) The model peak period used for this model is consistent with the network peak period (0800 – 0900 and 1700 – 1800).
- b) Based on the type of flow data available, traffic demand data was entered as ODTAB – synthesised from a peak hour turning-traffic counts.
- c) Heavy vehicle data was set up to vary over turning movement and inputted accordingly. The individual values for each turning movement were obtained from traffic survey data.
- d) Geometric parameters were attained from drawings provided by Kent County Council and Highways England.

7.19 Model results

The summarised results of the analysis are contained in Table 9 and refer, as in the priority-controlled roundabouts, to the Ratio of Flow to Capacity (RFC) of the junctions which is taken as the ratio of the flow to capacity on the worst performing arm of the junction. The full model outputs can be found in Electronic appendices listed on Appendix E.

All junctions perform to an acceptable level expect for junction 11 A20 Ashford Road/ A261 Hythe Road junction which performs with a RFC of 0.922 during the AM peak period as shown in Table 9.

Table 9. RFC Values for Priority Controlled Junctions

Junction	Location	AM	PM
3	Ashford Road (A20) / Swan Lane	0.395	0.289
4	Ashford Road (A20) / Stone Hill	0.238	0.144
5	Ashford Road (A20) / Station Road / Church Road	0.365	0.416
6	Hythe Road (A20) / Meersham	0.312	0.196
7	A2070 Kenniton Road / The Street	0.264	0.32
9	B2067 Otterpool Lane / Aldington Road	0.225	0.34
10	Aldington Road / Stone Street	0.389	0.613
11	A20 Ashford Road / A261 Hythe Road / Stone Street	0.922	0.603
12	Aldington Road / Lympne Hill	0.471	0.472
13	A261 Hythe Road / Aldington Road	0.419	0.318
14	A261 London Road / Barrack Hill	0.429	0.313
17	A20 Ashford Road / A20 J11 offslip	0.557	0.344
18	Ashford Road (A20) / Sandling Road	0.489	0.316
22	A20 Ashford Road / Stone Street	0.106	0.276
26	A259 Prospect Road / Stade Street	0.573	0.724
30	A260 Canterbury Road / Alkham Valley Road	0.606	0.578

8 Conclusion

The above document summarises the performance of the LinSig, Arcady and Picady model for the AM and PM peak period. The correct modelling packages have been used to model the impact of these junctions.

Overall, the base models are considered an acceptable tool for undertaking future year testing and accurately assess the impact of the Otterpool Park development.

APPENDIX A

Survey data report

OTTERPOOL PARK GARDEN SETTLEMENT

Traffic Survey Data Analysis

FEBRUARY 2018

Incorporating

EC HARRIS
BUILT ASSET
CONSULTANCY



CONTENTS

1	INTRODUCTION	1
1.1	Background.....	1
1.2	Structure of this Note.....	1
2	CLASSIFIED TURNING COUNT DATA.....	2
2.1	Data to be Used for Assessment	2
2.2	Peak Period Analysis	4
2.3	Analysis of Flow Volumes through Adjacent Junctions	5
2.3.1	Differences between In/Out Flows of Adjacent Junctions	5
2.3.2	Traffic Flow Difference Analysis and Recommendations	8
2.4	Comparison of 2013, 2016 and 2017 survey data in adjacent junctions.....	22
2.5	Forecast Traffic Flows for Future Case Modelling.....	24
3	ORIGIN-DESTINATION (OD) SURVEYS.....	25
4	CONCLUSION.....	27

FIGURES

Figure 1	Classified Turning counts locations.....	2
Figure 2	Classified turning counts peak period analysis.	5

TABLES

Table 1.	Summary of traffic counts.....	2
Table 2.	Classified turning counts list.....	3
Table 3	Summary of classified turning counts by category.	4
Table 4	AM Peak (8-9am) Traffic flow differences for adjacent surveyed junctions.	5
Table 5	PM Peak (5-6pm) Traffic flow differences for adjacent surveyed junctions.	6
Table 6	Traffic flow difference between adjacent junctions surveyed in different years.	22
Table 7.	Registered percentage of vehicles in the ANPR	26

APPENDICES

APPENDIX A

ANPR Camera locations

APPENDIX B

Classified Turning Counts (Summary)

1 Introduction

1.1 Background

Arcadis was appointed in August 2016 by Shepway District Council and Cozumel Estates to develop a masterplan and planning application in respect of the proposed garden settlement called Otterpool Park.

The scope of Transport work required for the application is being discussed with Kent County Council, Shepway District Council and Highways England. Traffic modelling has been requested to assess the performance of the network and determine the effect of the Otterpool Park development proposals, for which traffic survey data in the form of classified turning counts and origin-destination data is required. Some of the required traffic survey data was collected by Shepway District Council on Tuesday 22nd October 2013 and Thursday 13th October 2016 and this data has been made available to Arcadis for use on the Otterpool Park assessment. The remainder of the data required for the study was collected on 29th June 2017. This report has been produced to check the quality of the data collected in 2017 and to validate the flow volumes against the 2016 data.

1.2 Structure of this Note

The remainder of this Note is structured as follows:

- Section 2** **Classified Turning Counts**
- Section 3** **Origin-Destination Data**
- Section 4** **Conclusion**

2 Classified Turning Count Data

2.1 Data to be Used for Assessment

Table 1 summarises the traffic count data intended for use in the Otterpool Park traffic modelling.

Table 1. Summary of traffic counts

Data set	Dates	Locations	Details
Classified turning counts	29 th June 2017	19 sites within the study area	Fully classified turning counts, summarised in 15 minutes time intervals.
Classified turning counts	13 th October 2016	14 sites within the study area	Fully classified turning counts, summarised in 15 minutes time intervals.
TRADS	Extracted from database for June 2017 or October 2016	A number of sites on the M20	Highways England administered online database of counts collected using permanent traffic counters. Counts are available by time period and basic vehicle classification estimated by vehicle length.

Figure 1 shows the locations at which the Classified Turning Counts were undertaken and Table 2 provides a full list of these locations.

Figure 1 Classified Turning counts locations

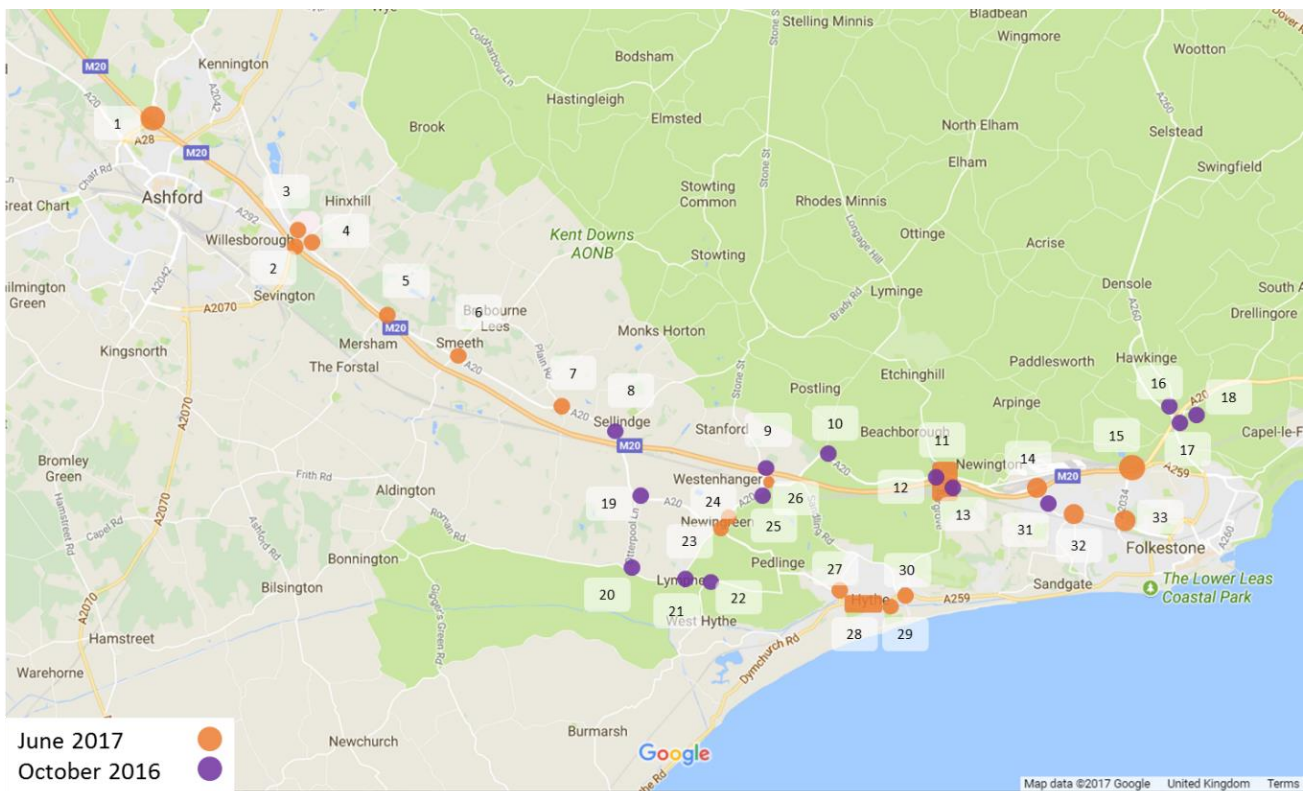

Otterpool Park Garden Settlement
Traffic Survey Data Analysis

Table 2. Classified turning counts list

Site ID	Survey date	Location
1	29/06/2017	M20 J9- signalised full OD including all on/ offslips and M20 overpass
2	29/06/2017	M20 J10- signalised roundabout- full OD (including underpass)
3	29/06/2017	Hythe Road (A20)/ The Street (West)- priority- turning counts
4	29/06/2017	Hythe Road (A20)/ The Street (East)- priority- turning counts
5	29/06/2017	Hythe Road (A20)/ Mersham- priority- turning counts
6	29/06/2017	Ashford Road (A20)/ Station Road/ Church Road- priority- turning counts
7	29/06/2017	Ashford Road (A20)/ Stone Hill- priority- turning count
8	13/10/2016	Ashford Road (A20)/ Swan Lane- priority- turning counts
9	13/10/2016	M20 J11- non-signalised roundabout- full OD (including overpass)
10	13/10/2016	Ashford Road/ Sandling Road- priority- turning counts
11	29/06/2017	M20 J11A- priority full OD required including all on/ offslips and M20 underpass
12	13/10/2016	Eurotunnel entry
13	13/10/2016	Eurotunnel exit
14	29/06/2017	M20 J12- priority full OD required including all on/ offslips and M20 overpass
15	29/06/2017	M20 J13- priority full OD required including all on/ offslips and M20 overpass
16	13/10/2016	White Horse Hill / A20 EB slips / A260 / A260 Spitfire Way
17	13/10/2016	A20 WB slips / Alkham Valley Road
18	13/10/2016	A260 Canterbury Road / Alkham Valley Road
19	13/10/2016	A20 Ashford Road/ B2067 Otterpool Lane- signalised junction- turning counts
20	13/10/2016	B2067 Otterpool Lane/ Aldington Road- priority- turning counts
21	13/10/2016	Aldington Road/ Stone Street- priority- turning counts
22	13/10/2016	Aldington Road/ Lypne Hill- priority- turning counts
23	29/06/2017	A20 Ashford Road/ A261 Hythe Road/Stone Street- priority- turning counts
24	29/06/2017	A20 Ashford Road/ Stone Street- priority- turning counts
25	13/10/2016	A20 Ashford Road roundabout
26	29/06/2017	A20 Ashford Road/ A20 J11 offslip- priority- turning counts
27	29/06/2017	A261 London Road/ Barrack Hill- priority- turning counts
28	29/06/2017	A259/ Dymchurch Road/ Military Road gyratory- signalised- full OD
29	29/06/2017	A259 Prospect Road / Stade Street – priority – turning counts
30	29/06/2017	A259 Prospect Road/ A259 Seabrook Road/ Station Road/ High Street- priority roundabout- full OD
31	22/10/2013	A20 Cheriton Interchange / B2064 Cheriton High Street
32	29/06/2017	B2064 Cheriton High street / B2063 Risborough Lane – priority – turning counts
33	29/06/2017	B2064 Cheriton High street / A2034 Cherry Garden avenue – priority – turning counts

2.2 Peak Period Analysis

A peak period analysis was carried out by combining counts for all the sites where classified turning counts were collected then producing total hourly flows (sum of the preceding four 15-minute periods). Table 3 and Figure 2 show the results of these calculations. The table and figure show that the AM and PM peak flow hours were observed to be 08:00-09:00 and 17:00-18:00 respectively.

Table 3 Summary of classified turning counts by category.

PERIOD	Time (Hour beginning)	HOURLY FLOWS										
		Car	Taxi	LGV	OGV 1	OGV 2	Bus	Coach	MCY	PCY	TOTAL	Only motorised
AM	07:00	35,628	4	7,507	948	1,149	279	365	326	109	46,315	46,206
	07:15	41,688	4	7,855	1,007	1,103	309	400	316	103	52,785	52,682
	07:30	46,670	4	7,695	1,124	1,092	300	398	317	90	57,690	57,600
	07:45	49,727	4	7,325	1,239	1,071	259	398	296	68	60,387	60,319
	08:00	50,382	8	6,728	1,298	1,061	247	419	285	71	60,499	60,428
	08:15	47,750	16	6,376	1,341	1,091	220	405	274	61	57,534	57,473
	08:30	43,788	19	6,134	1,349	1,196	243	404	236	69	53,438	53,369
	08:45	38,681	23	5,933	1,285	1,174	228	388	242	74	48,028	47,954
	09:00	34,639	22	5,803	1,333	1,196	234	385	222	111	43,945	43,834
PM	16:00	45,692	9	7,390	842	972	229	383	460	80	56,057	55,977
	16:15	48,534	7	7,215	781	958	224	361	483	92	58,655	58,563
	16:30	51,190	5	6,912	654	889	216	330	482	102	60,780	60,678
	16:45	53,046	1	6,442	546	888	227	295	495	109	62,049	61,940
	17:00	54,260	2	5,861	497	862	232	278	529	125	62,646	62,521
	17:15	51,968	2	5,131	464	827	220	282	507	134	59,535	59,401
	17:30	48,408	2	4,467	457	858	222	280	437	139	55,270	55,131
	17:45	43,992	1	3,825	420	829	205	270	405	142	50,089	49,947
	18:00	39,956	-	3,298	377	796	171	233	391	134	45,356	45,222

Figure 2 Classified turning counts peak period analysis.

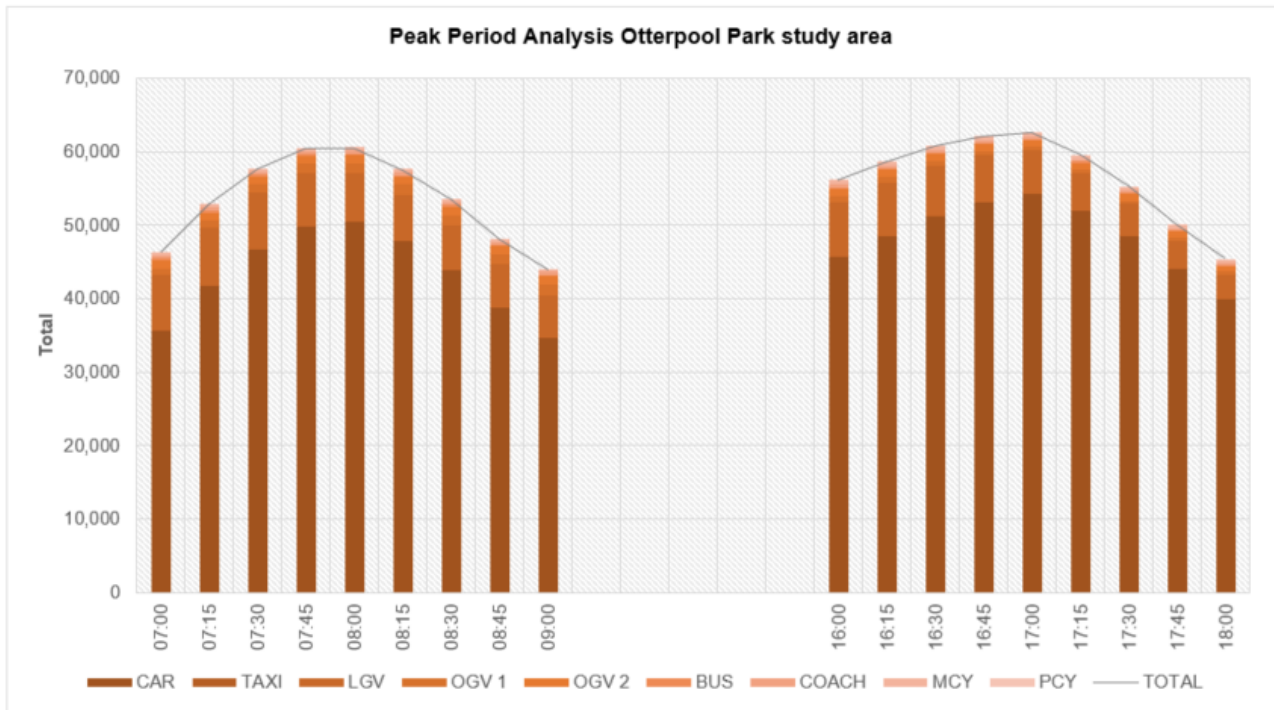

2.3 Analysis of Flow Volumes through Adjacent Junctions

2.3.1 Differences between In/Out Flows of Adjacent Junctions

A comparison of traffic flow volumes through adjacent junctions was carried out among the locations previously presented in Figure 1. The flow into the two junctions in each direction has been compared to the flow out of the junctions. Variances in flows were to be expected due to the date difference among some of the surveys and results are presented in Table 4 and Table 5.

Table 4 AM Peak (8-9am) Traffic flow differences for adjacent surveyed junctions.

2-3	WB	EB
IN	797	420
OUT	798	435
Diff	0%	4%

23-24	NB	SB
IN	723	647
OUT	724	646
Diff	0%	0%

22-21	EB	WB
IN	189	272
OUT	182	310
Diff	-4%	14%

2-4	WB	EB
IN	876	695
OUT	876	660
Diff	0%	-5%

11-14	NB	SB
IN	605	541
OUT	412	606
Diff	-32%	12%

10-11	EB	WB
IN	139	101
OUT	101	91
Diff	-27%	-10%

4-5	WB	EB
IN	611	548
OUT	627	522
Diff	3%	-5%

32-33	WB	EB
IN	332	537
OUT	474	562
Diff	43%	5%

14-31	EB	WB
IN	1126	927
OUT	1135	1117
Diff	1%	20%

Otterpool Park Garden Settlement
Traffic Survey Data Analysis

6-5	WB	EB
IN	408	449
OUT	528	380
Diff	29%	-15%

8-7	EB	WB
IN	284	397
OUT	290	374
Diff	2%	-6%

32-31	EB	WB
IN	568	580
OUT	477	637
Diff	-16%	10%

6-7	WB	EB
IN	319	239
OUT	297	209
Diff	-7%	-13%

8-19	EB	WB
IN	258	266
OUT	254	314
Diff	-2%	18%

26-9	NB	SB
IN	975	826
OUT	928	869
Diff	-5%	5%

28-27	WB	EB
IN	584	537
OUT	573	517
Diff	-2%	-4%

20-19	SB	NB
IN	245	190
OUT	98	196
Diff	-60%	3%

24-25	NB	SB
IN	727	713
OUT	728	662
Diff	0%	-7%

28-29	WB	EB
IN	434	901
OUT	425	891
Diff	-2%	-1%

20-21	EB	WB
IN	92	183
OUT	80	136
Diff	-13%	-26%

26-25	NB	SB
IN	980	920
OUT	975	964
Diff	-1%	5%

30-29	WB	EB
IN	565	826
OUT	522	785
Diff	-8%	-5%

23-21	NB	SB
IN	175	141
OUT	288	157
Diff	65%	11%

Table 5 PM Peak (5-6pm) Traffic flow differences for adjacent surveyed junctions.

2-3	WB	EB
IN	472	647
OUT	457	647
Diff	-3%	0%

23-24	NB	SB
IN	693	766
OUT	693	766
Diff	0%	0%

22-21	EB	WB
IN	331	122
OUT	309	137
Diff	-7%	12%

2-4	WB	EB
IN	827	823
OUT	824	844
Diff	0%	3%

11-14	NB	SB
IN	502	411
OUT	471	624
Diff	-6%	52%

10-11	EB	WB
IN	88	72
OUT	75	64
Diff	-15%	-11%

4-5	WB	EB
IN	486	698
OUT	504	654
Diff	4%	-6%

32-33	WB	EB
IN	351	685
OUT	533	617
Diff	52%	-10%

14-31	EB	WB
IN	1358	1083
OUT	1208	1135
Diff	-11%	5%

6-5	WB	EB
IN	371	577
OUT	445	526
Diff	20%	-9%

8-7	EB	WB
IN	431	283
OUT	412	315
Diff	-4%	11%

32-31	EB	WB
IN	746	663
OUT	685	618
Diff	-8%	-7%

Otterpool Park Garden Settlement
Traffic Survey Data Analysis

6-7	WB	EB
IN	268	372
OUT	294	391
Diff	10%	5%

8-19	EB	WB
IN	313	258
OUT	271	271
Diff	-13%	5%

26-9	NB	SB
IN	846	986
OUT	744	1020
Diff	-12%	3%

28-27	WB	EB
IN	460	658
OUT	453	636
Diff	-2%	-3%

20-19	SB	NB
IN	125	90
OUT	145	323
Diff	16%	259%

24-25	NB	SB
IN	720	732
OUT	678	767
Diff	-6%	5%

28-29	WB	EB
IN	610	936
OUT	604	936
Diff	-1%	0%

20-21	EB	WB
IN	147	104
OUT	140	75
Diff	-5%	-28%

26-25	NB	SB
IN	802	871
OUT	846	856
Diff	5%	-2%

30-29	WB	EB
IN	700	774
OUT	700	826
Diff	0%	7%

23-21	NB	SB
IN	96	269
OUT	140	254
Diff	46%	-6%

Following best practice guidelines, surveys collected on the same date with flow differences above 5% have been subject to a detailed analysis in section 2.3.2. There are no guideline stating a threshold flow difference for traffic surveys done on a different day however we decided to use a 15% threshold based on Arcadis best practice. This 15% threshold allow to identify gaps within the traffic survey which need to be addressed.

2.3.2 Traffic Flow Difference Analysis and Recommendations

This section presents a detailed analysis of the traffic surveys where the difference between in and out flows recorded through adjacent junctions is greater than 15%. Recommendations are also given in regard to the actions involved in the modelling process.

2.3.2.1 Junctions 22-21



AM			PM		
22-21	EB	WB	22-21	EB	WB
IN	189	272	IN	331	122
OUT	182	310	OUT	309	137
Diff	-4%	15%	Diff	-7%	12%

Both junctions were surveyed on October 13th 2016.

The difference could be explained by the presence of a residential access road (Octavian Drive). There is no vehicle access between Aldington Road and Berwick Lane (Pedestrian only).

Modelling Recommendation: A zone near Octavian Drive can be added to represent flows coming in and out of the residential area.

2.3.2.2 Junctions 11-14

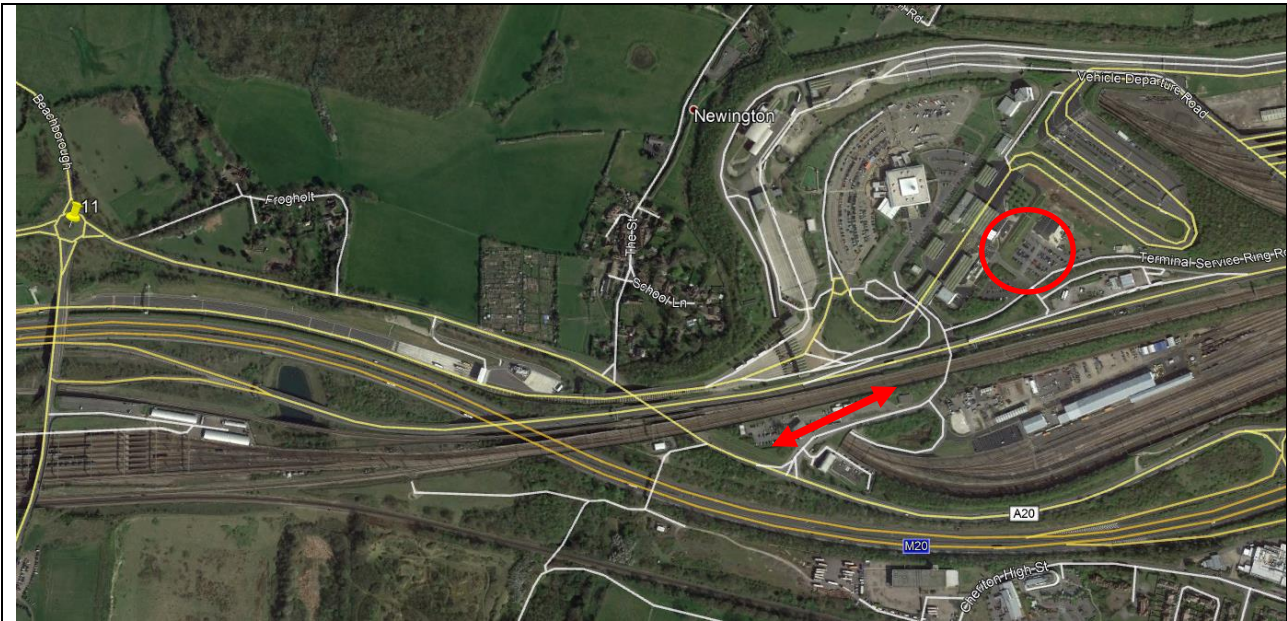

AM			PM		
11-14	WB	EB	11-14	WB	EB
IN	605	541	IN	502	411
OUT	412	606	OUT	471	624
Diff	-32%	12%	Diff	-6%	52%

Both junctions were surveyed on June 29th 2017.

The difference is likely to be explained by the presence of one of the Terminal Service Roads of the Eurotunnel, providing access to one of the main staff buildings and car parks.

Modelling Recommendation: A new link (Terminal Service Road) and zone (Car park) can be added to the current network in order to represent the traffic generated/attracted by the buildings and car parks.

2.3.2.3 Junctions 10-11

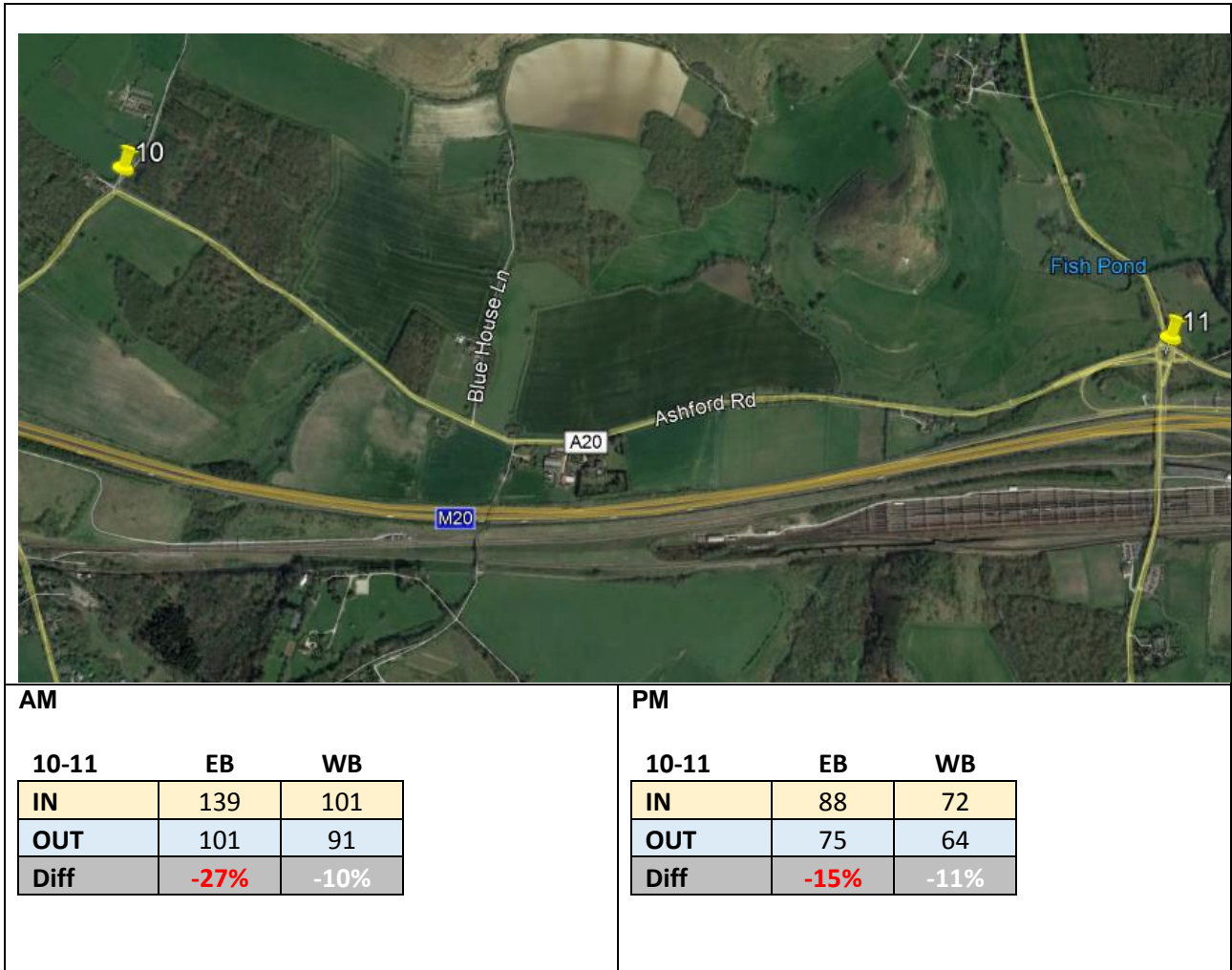

Site 10 was surveyed on October 13th 2016 and Site 11 was surveyed on June 29th 2017.

The westbound difference could be explained by the slip road connecting to the Eurotunnel entrance from site 11. However, there are no relevant intermediate junctions between the two sites in the eastbound flow, which suggests that the flow difference could be attributed by the date difference between the two traffic surveys.

Modelling Recommendation: A new zone can be created to represent the Eurotunnel entrance in regards of the westbound flow difference. In terms of the eastbound flow difference, both sets of data (eastbound flows from the two surveys) should be growth separately assuring flows are balanced in the baseline scenario year.

2.3.2.4 Junctions 32-33

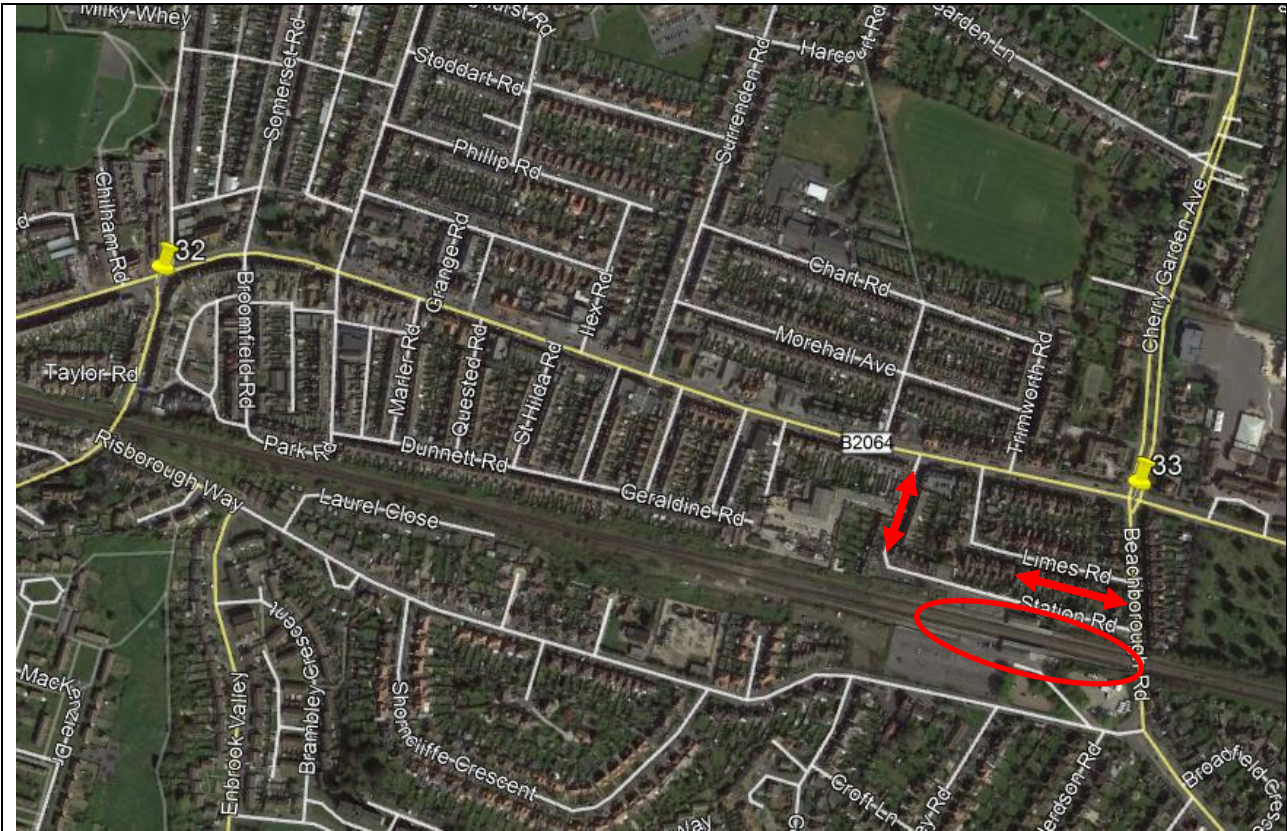

AM			PM		
32-33	WB	EB	32-33	WB	EB
IN	332	537	IN	351	685
OUT	474	562	OUT	533	617
Diff	43%	5%	Diff	52%	-10%

Both junctions were surveyed on June 29th 2017.

This is mainly a residential area with a railway station (Folkestone West) on Station Road, which is between the two surveyed junctions. The difference could be attributed to the traffic dynamic created by the presence of the railway station and the several access roads to residential developments in the vicinity of the junctions.

Modelling Recommendation: Two zones can be created; one zone south of Cheriton Road to represent the flow from/to the railway station and the residential developments south of the main road, and another zone north of Cheriton Road to represent the residential developments on that side of the main road.

2.3.2.5 Junctions 14-31

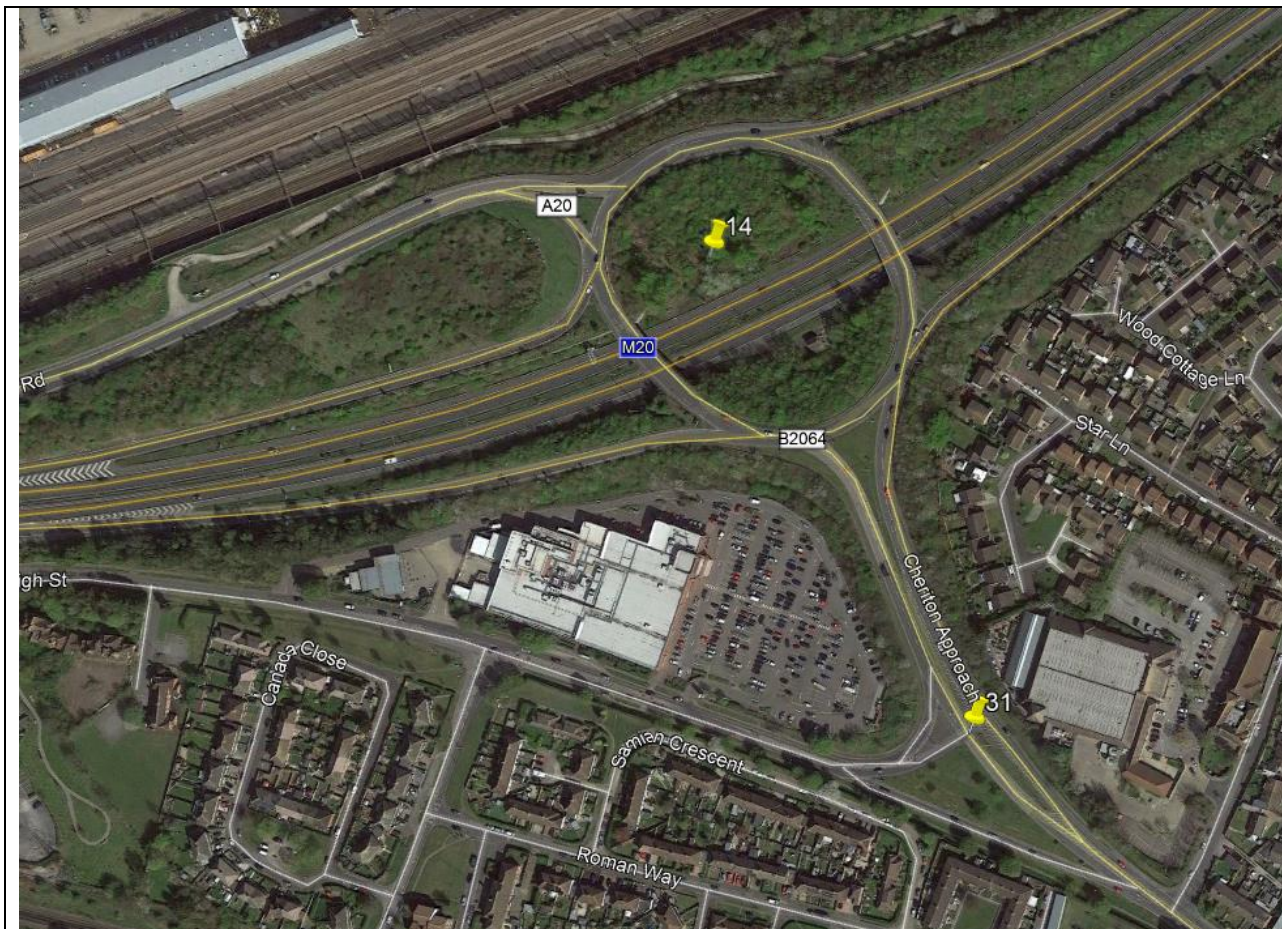

AM			PM		
14-31	EB	WB	14-31	EB	WB
IN	1126	927	IN	1358	1083
OUT	1135	1117	OUT	1208	1135
Diff	1%	20%	Diff	-11%	5%

Site 31 was surveyed on October 22nd 2013 and Site 14 was surveyed on June 29th 2017.

The only plausible reason for the given gap is the date difference between the surveys (more than 3 years).

Modelling Recommendation: Both sets of data will be growth separately making sure flows are balanced in the baseline scenario year. No further action to be taken.

2.3.2.6 Junctions 6-5



AM		
6-5	WB	EB
IN	408	449
OUT	528	380
Diff	29%	-15%

PM		
6-5	WB	EB
IN	371	577
OUT	445	526
Diff	20%	-9%

Both junctions were surveyed by on June 29th 2017.

The difference could be explained by the presence of an alternative route for the residents of Brabourne Lees travelling west; they could use The Ridgeway to access/exit the A20 instead of going through the A20/Church Road junction.

Modelling Recommendation: A new zone can be created to represent the traffic flow using the alternative route.

2.3.2.7 Junctions 32-31

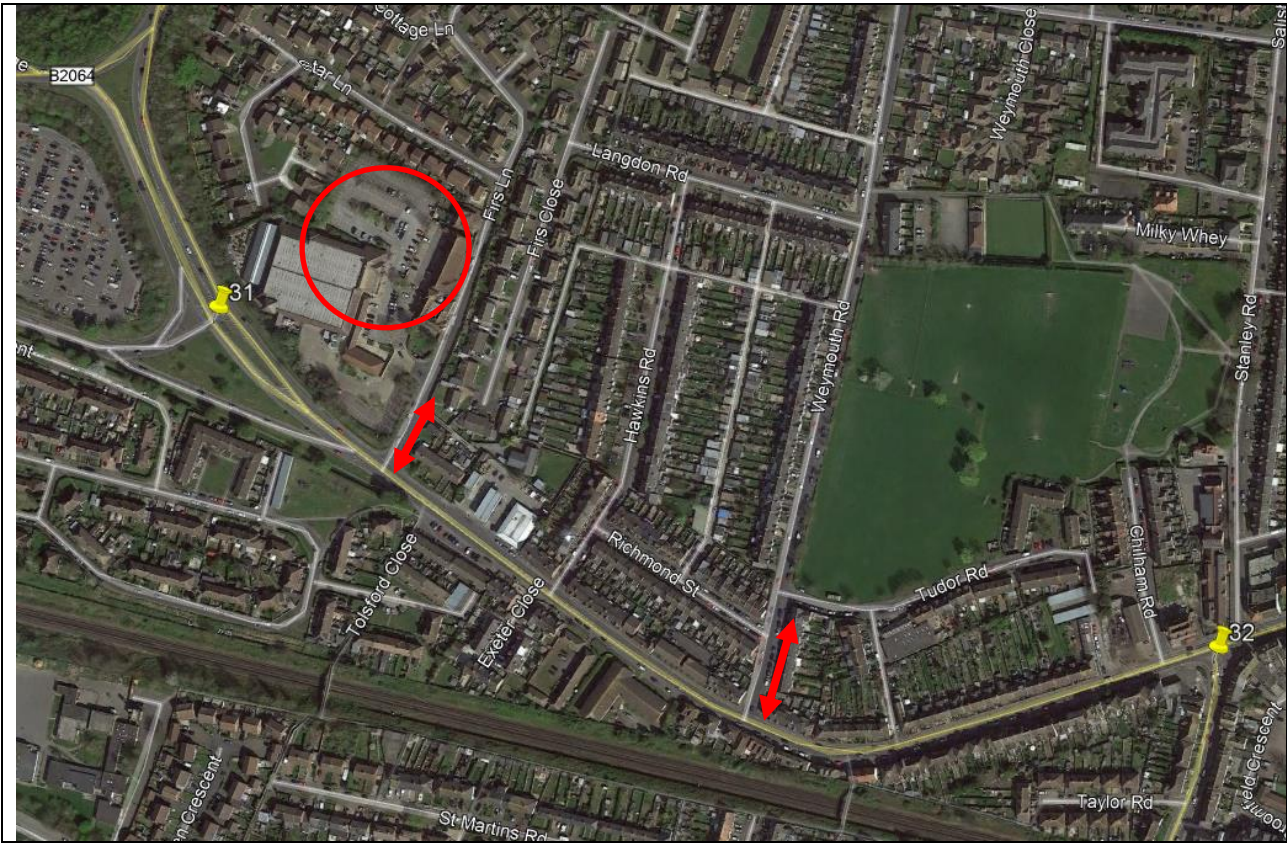

AM			PM		
32-31	EB	WB	32-31	EB	WB
IN	568	580	IN	746	663
OUT	477	637	OUT	685	618
Diff	-16%	10%	Diff	-8%	-7%

Site 31 was surveyed on October 22nd 2013 and Site 32 was surveyed on June 29th 2017.

Apart from the date difference (more than 3 years) there are two roads that could potentially explain the flow differences; Firs Lane provides access to a home, garden and goods retailer with nearly 100 parking spaces, and Weymouth Road, provides access to several residential developments north of site 31.

Modelling Recommendation: A single zone north of the site 31 can be added to represent both; the residential area and the retail centre in/out traffic flows.

2.3.2.8 Junctions 8-19

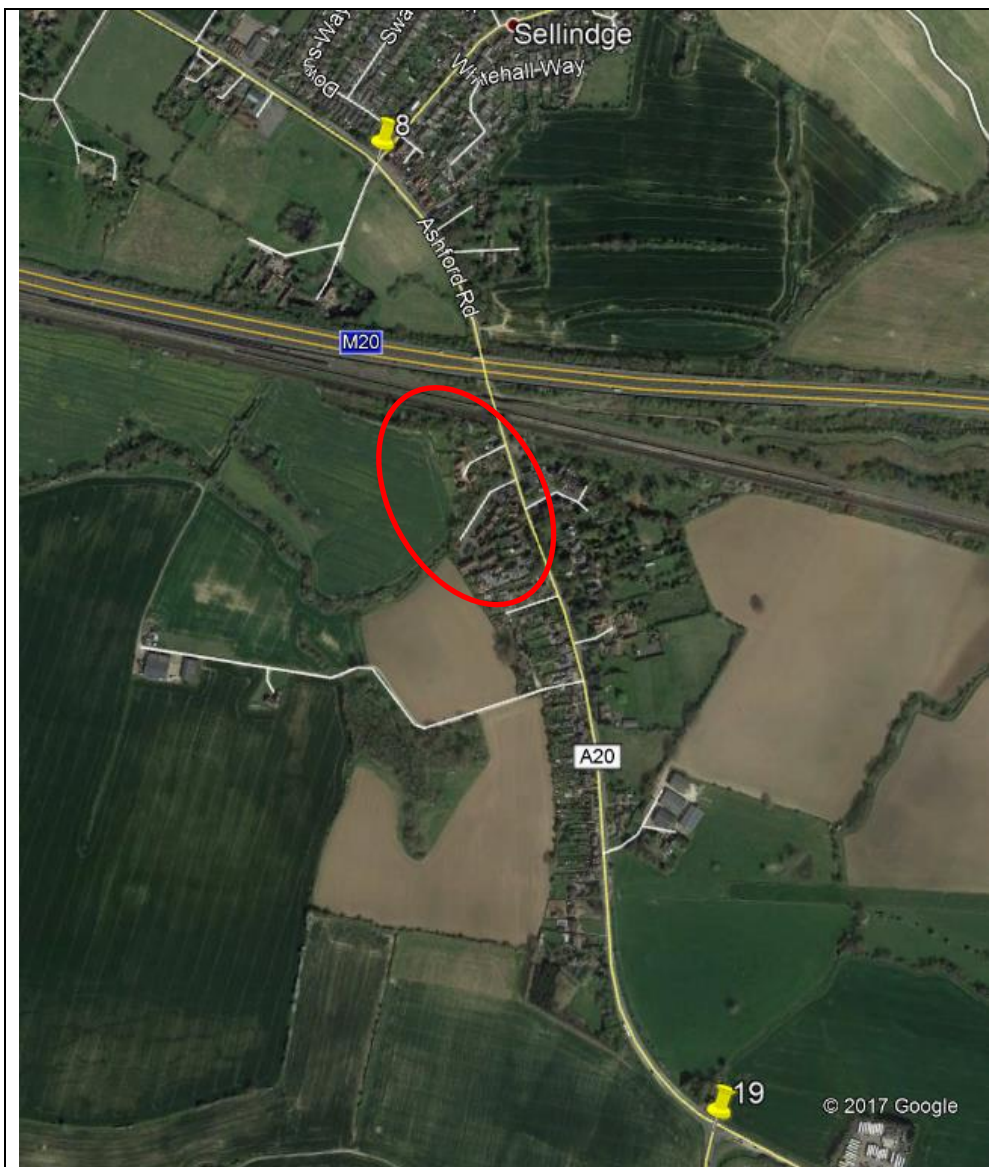

AM			PM		
8-19	EB	WB	8-19	EB	WB
IN	258	266	IN	313	258
OUT	254	314	OUT	271	271
Diff	-2%	18%	Diff	-13%	5%

Both junctions were surveyed on October 13th 2016.

The difference could be explained by the presence of a series of small residential developments between the two junctions.

Modelling Recommendation: A single zone with a linked to either way of the A20 can be added to represent the traffic flows from/to the residential area.

2.3.2.9 Junctions 20-19

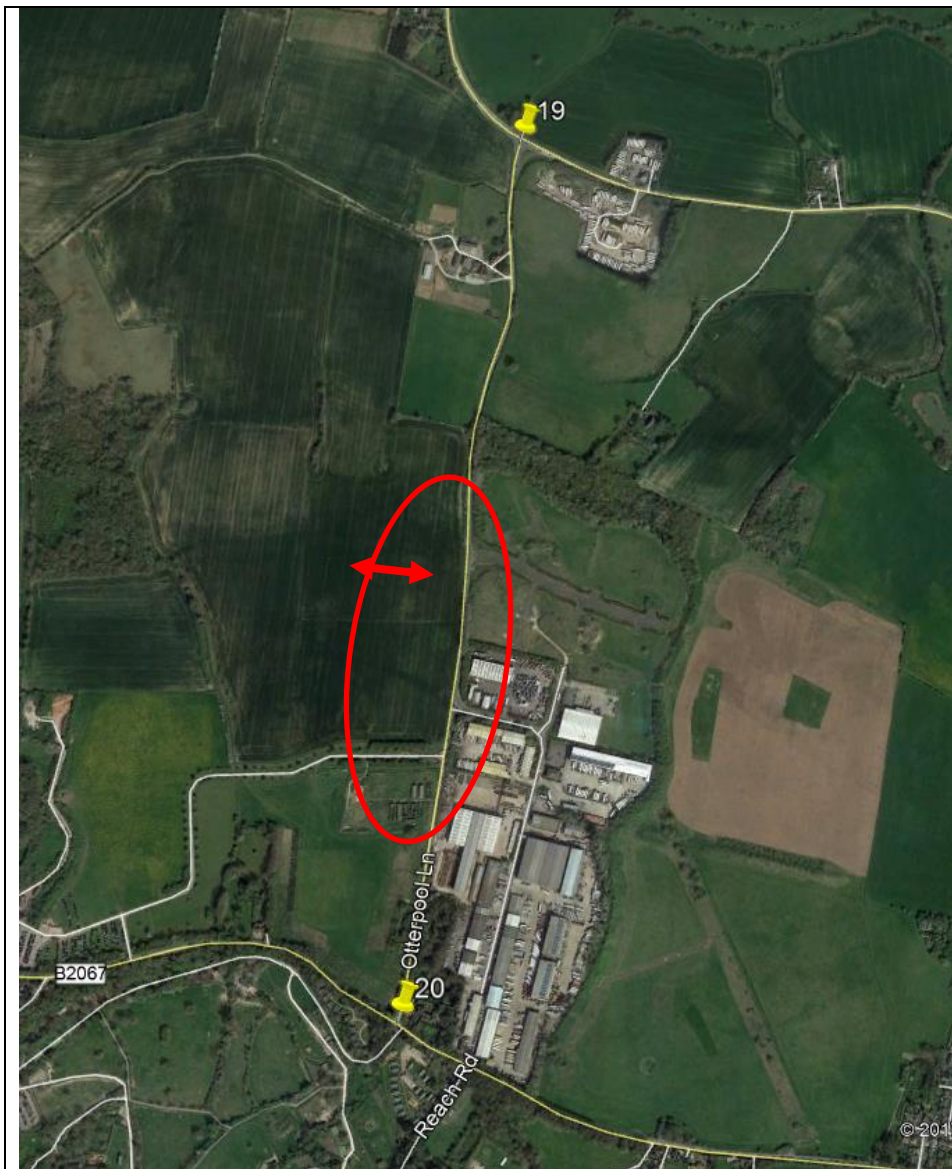

AM			PM		
20-19	SB	NB	20-19	SB	NB
IN	245	190	IN	125	90
OUT	98	196	OUT	145	323
Diff	-60%	3%	Diff	16%	259%

Both junctions were surveyed on October 13th 2016.

The difference could be explained by the presence the Lympe Industrial Park between the two junctions attracting trips in the AM period and generating them in the PM.

Modelling Recommendation: A zone can be added to represent the main entrance/exit of the Lympe Industrial Park.

2.3.2.10 Junctions 20-21



AM			PM		
20-21	EB	WB	20-21	EB	WB
IN	92	183	IN	147	104
OUT	80	136	OUT	140	75
Diff	-13%	-26%	Diff	-5%	-28%

Both junctions were surveyed on October 13th 2016.

There are two places between the two junctions that could potentially attract trips in both periods. A road access to the Port Lymgne mansion which is now a hotel and a conference centre near site 20 and a residential development on beacon way, near site 21 with approximately 40 dwellings.

Modelling Recommendation: A zone between site 20 and site 21 can be added to represent the flows entering/exiting the residential development and the Port Lymgne Hotel.

2.3.2.11 Junctions 23-21

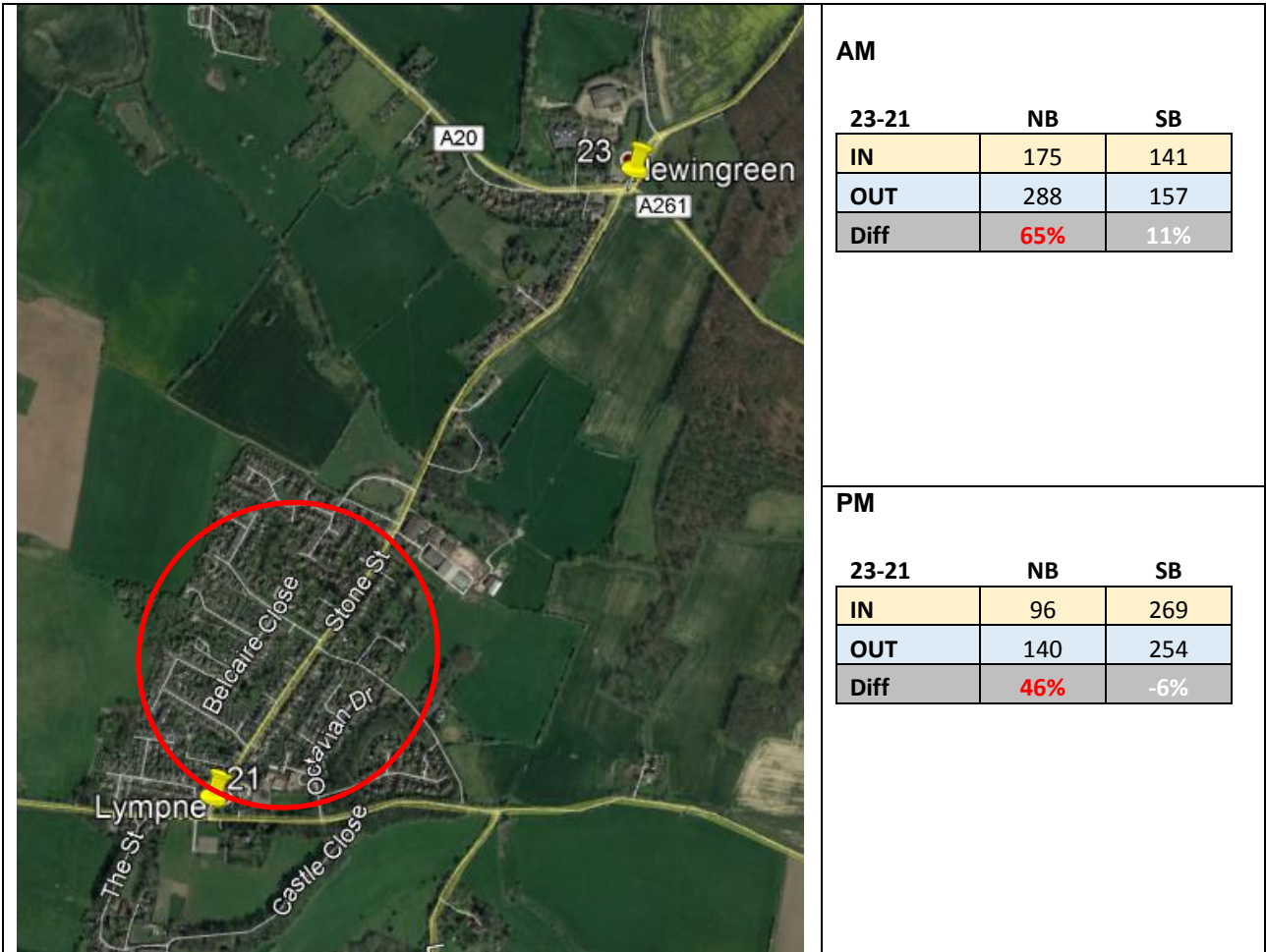

Site 21 was surveyed on October 13th 2016 and Site 23 was surveyed on June 29th 2017.

Even though part of the difference could be explained by the date difference, there are 4 access roads to at least 100 dwellings between the two junctions.

Modelling Recommendation: A single zone linked to either way of Stone Street can be added to represent the traffic flows from/to the residential area.

2.3.2.12 Junctions 6-7

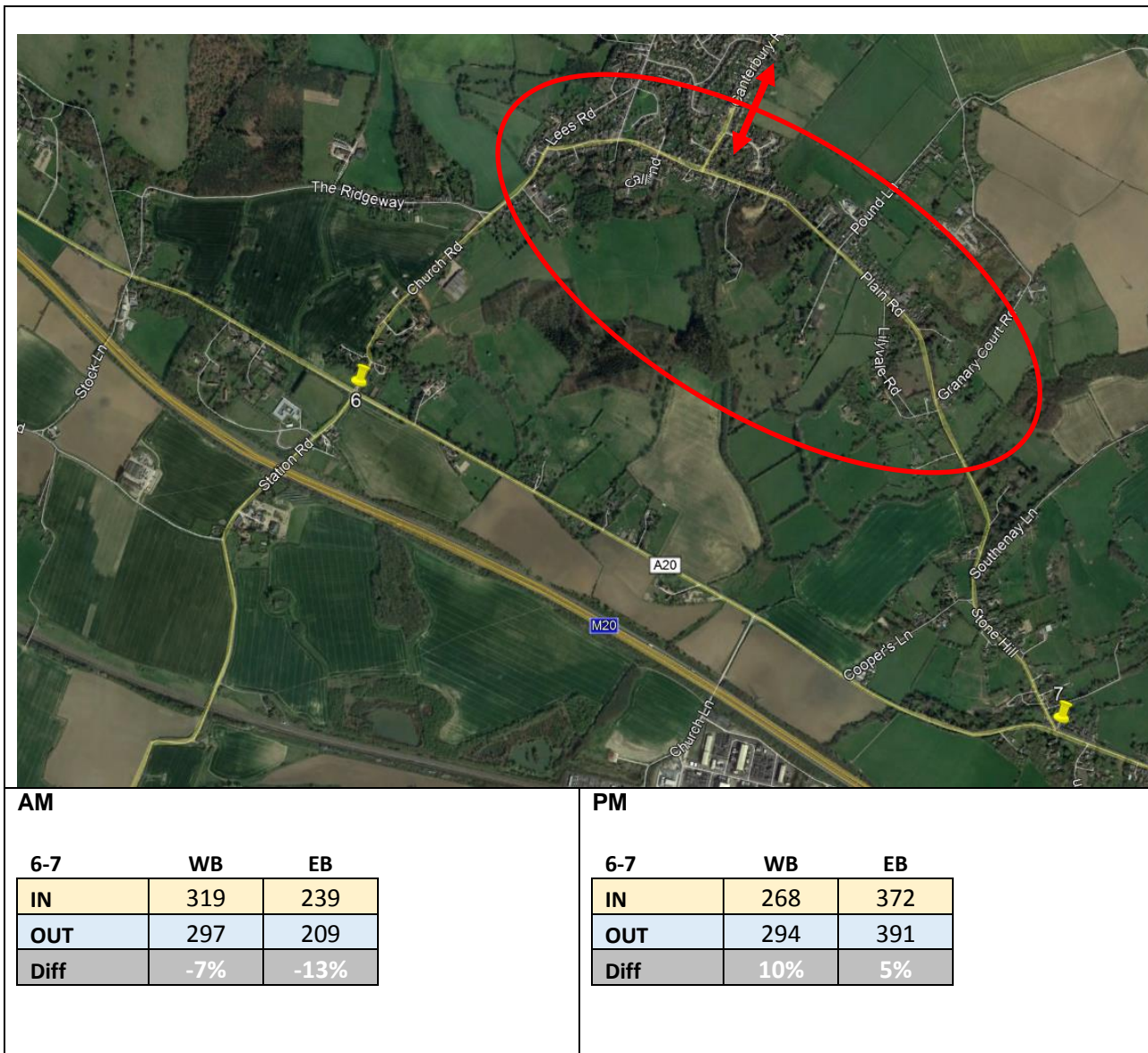

Both junctions were surveyed by on June 29th 2017.

The difference could be explained by the presence of a series of secondary roads providing access to small settlements both sides of the A20.

Modelling Recommendation: A single zone linked to either way of the A20 can be added to represent the traffic flows leaving/entering the A20.

2.3.2.13 Junctions 4-5

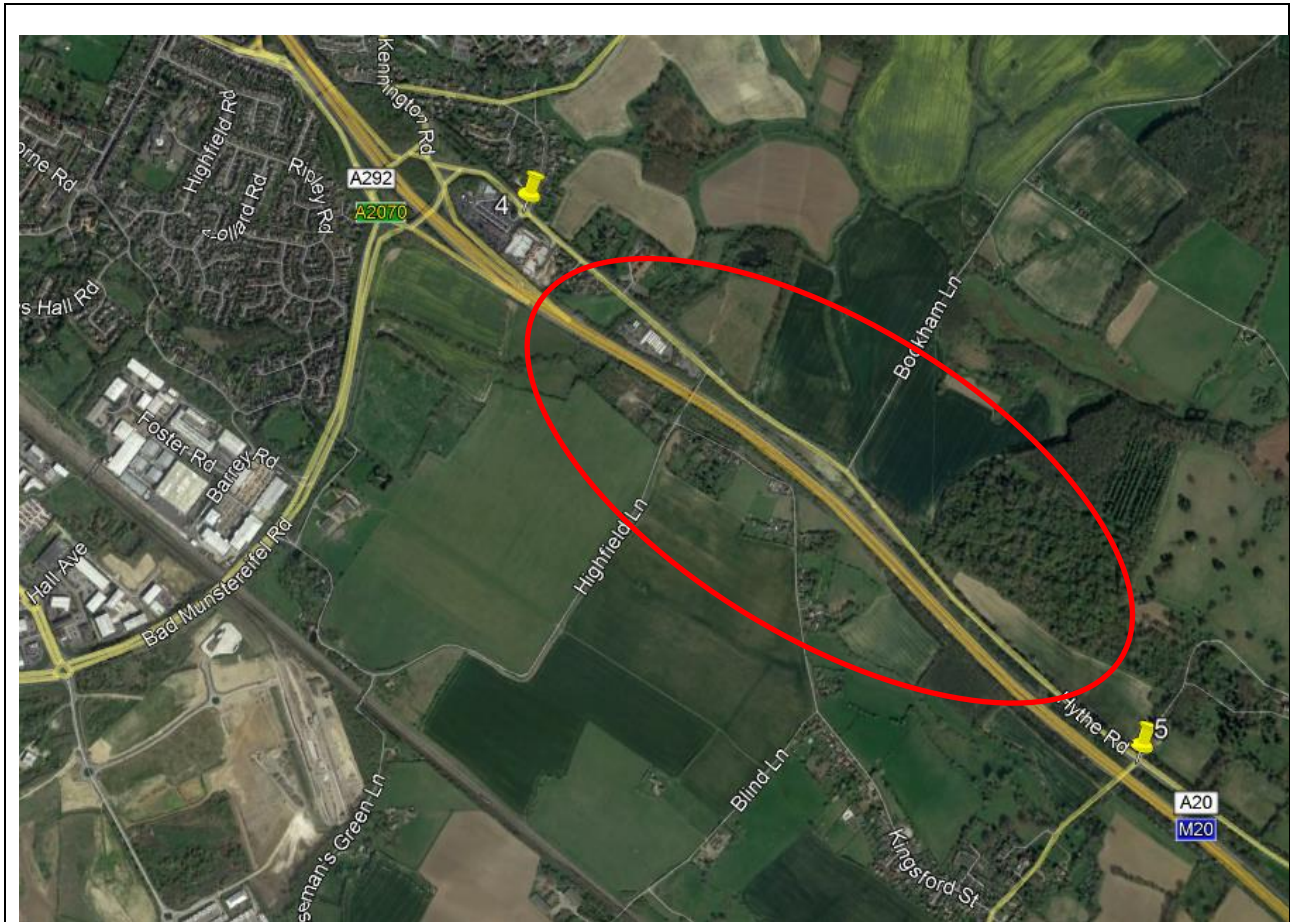

AM			PM		
4-5	WB	EB	4-5	WB	EB
IN	611	548	IN	486	698
OUT	627	522	OUT	504	654
Diff	3%	-5%	Diff	4%	-6%

Both junctions were surveyed by on June 29th 2017.

The difference could be explained by the presence of a series of rural access roads both sides of the Hythe Road.

Modelling Recommendation: Given the small differences in vehicles, there is no need to create a new zone among the two junctions, however, special care should be taken during the calibration process.

2.3.2.14 Junctions 30-29



AM			PM		
30-29	WB	EB	30-29	WB	EB
IN	565	826	IN	565	826
OUT	522	785	OUT	522	785
Diff	-7.6%	-5.0%	Diff	-7.6%	-5.0%

Both junctions were surveyed by on June 29th 2017.

The difference could be explained by the presence of a series of residential access roads north side of Prospect Road.

Modelling Recommendation: Based on the short number of vehicles “lost” between the two junctions, there is no need to create a new zone, however, special care should be taken during the calibration process.

2.4 Comparison of 2013, 2016 and 2017 survey data in adjacent junctions

Table 6 presents an additional analysis between adjacent junctions surveyed in different years, regardless of the difference percentage.

Table 6 Traffic flow difference between adjacent junctions surveyed in different years.

Link	Site Code	Survey Date	Traffic flow	AM (08:00 - 09:00)		PM (17:00 - 18:00)		Observation
				EB	WB	EB	WB	
			Direction of Flow	EB	WB	EB	WB	
7-8	7	29/06/2017	In	284	-	431	-	The differences are relatively marginal, with no relevant intermediate junctions between the two sites.
			Out	-	374	-	315	
	8	13/10/2016	In	-	397	-	283	
			Out	290	-	412	-	
			<i>Difference</i>	-2.1%	-5.8%	-4.4%	-10.2%	
			Direction of Flow	NB	SB	NB	SB	
23-21	23	29/06/2017	In		141		269	As explained in section 2.3.2.13, along with the date difference, there are 4 access roads to at least 100 dwellings between the two junctions.
			Out	288		140		
	21	13/10/2016	In	175		96		
			Out		157		254	
			<i>Difference</i>	64.6%	-10.2%	45.8%	5.9%	
			Direction of Flow	EB	WB	EB	WB	
11-10	11	29/06/2017	In		101		72	The Westbound (WB) difference could be explained by the slip road connecting to the Eurotunnel entrance from site 11. However, there are no relevant intermediate junctions between the two sites in the Eastbound (EB) flow
			Out	101		75		
	10	13/10/2016	In	139		88		
			Out		91		64	
			<i>Difference</i>	-27.3%	11.0%	-14.8%	12.5%	
			Direction of Flow	EB	WB	EB	WB	
14-31	14	29/06/2017	In	1126		1358		The only plausible reason for the given difference is the date difference between the surveys (more than 3 years).
			Out		1117		1135	
	31	22/10/2013	In		927		1083	
			Out	1135		1208		
			<i>Difference</i>	-0.8%	20.5%	-11.0%	-4.6%	

Otterpool Park Garden Settlement
Traffic Survey Data Analysis

Link	Site Code	Survey Date	Traffic flow	AM (08:00 - 09:00)		PM (17:00 - 18:00)		Observation
			Direction of Flow	EB	WB	EB	WB	
32-31	32	29/06/2017	In		580		663	Apart from the date difference (more than 3 years) there are two roads that could potentially explain the flow differences; Firs Lane provide access to the "range", a home, garden & goods retailer with nearly 100 park spaces. And Weymouth Road, which provides access to several residential developments north of the B2064
			Out	477		685		
	31	22/10/2013	In	568		746		
			Out		637		618	
				<i>Difference</i>	-16.0%	-8.9%	-8.2%	
			Direction of Flow	NB	SB	NB	SB	
26-9	26	29/06/2017	In	975		846		With no evident developments between the two junctions, the only plausible reason for the flow variation is the date difference between the surveys
			Out		869		1020	
	9	13/10/2016	In		826		986	
			Out	928		744		
				<i>Difference</i>	5.1%	5.2%	-12.1%	
			Direction of Flow	NB	SB	NB	SB	
24-25	24	29/06/2017	In	727		720		With no intermediate junctions between the two sites and a distance less than 200 metres amongst the two junctions. It is suggested that the flow difference is attributed to the season variation.
			Out		662		767	
	25	13/10/2016	In		713		732	
			Out	728		678		
				<i>Difference</i>	-0.1%	-7.2%	-5.8%	
			Direction of Flow	NB	SB	NB	SB	
26-25	26	29/06/2017	In		920		871	With no intermediate junctions between the two sites and a distance less than 200 metres amongst the two junctions. It is suggested that the flow difference is attributed to the season variation.
			Out	975		846		
	25	13/10/2016	In	980		802		
			Out		964		856	
				<i>Difference</i>	-0.5%	-4.6%	5.5%	

2.5 Forecast Traffic Flows for Future Case Modelling

Three baseline scenarios will be modelled, as follows:

1. Application year – 2018;
2. End of local plan – 2037; and
3. Opening year with full occupation – year to be determined.

We proposed to use the NTM AF15 dataset and TEMPro v7.2 to growth the 2016 and 2017 traffic surveys to 2018 for the application year scenario.

The baseline flows for the other two scenarios will be based on a combination of baseline flows from the SETRM and TEMPro. For example, we understand that there is an SETRM for 2031; we will therefore use the flows from this model and apply a TEMPro factor to growth them to 2037.

3 Origin-Destination (OD) surveys

An Automatic Number Plate Recognition (ANPR) survey has been undertaken for a 12-hour period, between 07:00 and 19:00 on the same day as the classified turning counts in June 2017. During this period, vehicle registration plates have been recorded by vehicle type: light vehicles, heavy vehicles and public service vehicles (PSV) in 62 cameras located along the study area. ANPR provides information of the routes used by vehicles and number of vehicles using these routes within the study area.

The location of the cameras can be found in Appendix A.

Journey times will be extracted from the OD surveys. During the OD surveys, the vehicle registration plates were recorded together with a “time-stamp”. This allows extraction of journey times between the various camera locations. It is noted that only journey times within the 90th percentile have been taken into account, as it has been assumed that journey times outside this range mean that a vehicle has done intermediate stops within the network before arriving to the destination point.

Table 7 presents the capture rate of registered vehicles per ANPR site. The overall captured rate is above 95% for the AM and PM peak period, only two sites (43 and 46) registered a capture rate below 95%. The small number of sites with a match lower than 95% gives us a high degree of confidence in the surveys quality.

Otterpool Park Garden Settlement
Traffic Survey Data Analysis

Table 7. Registered percentage of vehicles in the ANPR

ANPR site	8:00-9:00			17:00-18:00		
	MCC	ANPR	% registered	MCC	ANPR	% registered
01	1744	1690	97%	1856	1781	96%
02	347	326	94%	403	398	99%
03	1612	1564	97%	1518	1465	97%
04	2485	2367	95%	3430	3231	94%
05	690	682	99%	320	316	99%
06	457	446	98%	675	666	99%
07	135	128	95%	129	125	97%
08	197	190	96%	161	158	98%
09	1641	1542	94%	1935	1883	97%
10	1723	1645	95%	2018	1925	95%
11	116	114	98%	122	115	94%
12	120	120	100%	80	80	100%
13	97	97	100%	147	145	99%
14	107	106	99%	52	50	96%
15	79	78	99%	129	128	99%
16	130	127	98%	87	83	95%
17	61	59	97%	48	44	92%
18	73	72	99%	42	42	100%
19	94	91	97%	178	174	98%
20	180	175	97%	131	129	98%
21	375	372	99%	384	382	99%
22	349	338	97%	402	398	99%
23	156	154	99%	159	152	96%
24	172	169	98%	121	119	98%
25	267	263	99%	312	309	99%
26	277	274	99%	283	275	97%
27	64	55	86%	125	122	98%
28	156	153	98%	130	126	97%
29	335	325	97%	504	500	99%
30	389	382	98%	282	280	99%
31	107	99	93%	214	194	91%
32	224	211	94%	94	93	99%
33	339	335	99%	556	554	100%
34	410	406	99%	311	309	99%
35	285	272	95%	519	508	98%
36	386	385	100%	290	282	97%
37	669	635	95%	763	727	95%
38	729	711	98%	720	707	98%
39	221	220	100%	258	252	98%
40	264	259	98%	144	143	99%
41	179	174	97%	239	232	97%
42	267	262	98%	200	197	99%
43	379	302	80%	285	276	97%
45	1330	1184	89%	1870	1753	94%
46	2673	2275	85%	1728	1357	79%
47	216	213	99%	142	140	99%
48	208	206	99%	146	143	98%
49	27	25	93%	13	13	100%
50	1	1	100%	6	6	100%
51	36	36	100%	28	28	100%
52	101	100	99%	168	165	98%
53	505	501	99%	823	820	100%
54	921	909	99%	682	664	97%
55	225	223	99%	224	221	99%
56	357	348	97%	337	334	99%
57	607	600	99%	685	679	99%
58	532	499	94%	678	670	99%

4 Conclusion

Traffic flow differences between sites have been observed and explained. The structure of the VISSIM and VISUM models will provide additional zones and network structures to mitigate these differences where required.

Some discrepancies between data of difference ages have been identified at some locations but most of the data is acceptable. A decision will be made during the validation of the VISUM model to readjust the 2016 surveys to reduce the gaps but at this point the analysis shows that it is not a source of concern and does not need immediate mitigation.

The ANPR data shows a good sample rate against manual turning count and also shows that the data can be used to capture the journey time.

Overall the data check has shown no significant issues with the data set and demonstrated that the data is fit for purpose. It is proposed to proceed with the traffic modelling with this data set.

APPENDIX A

ANPR Camera locations



Otterpool Park Garden Settlement
 Traffic Survey Data Analysis

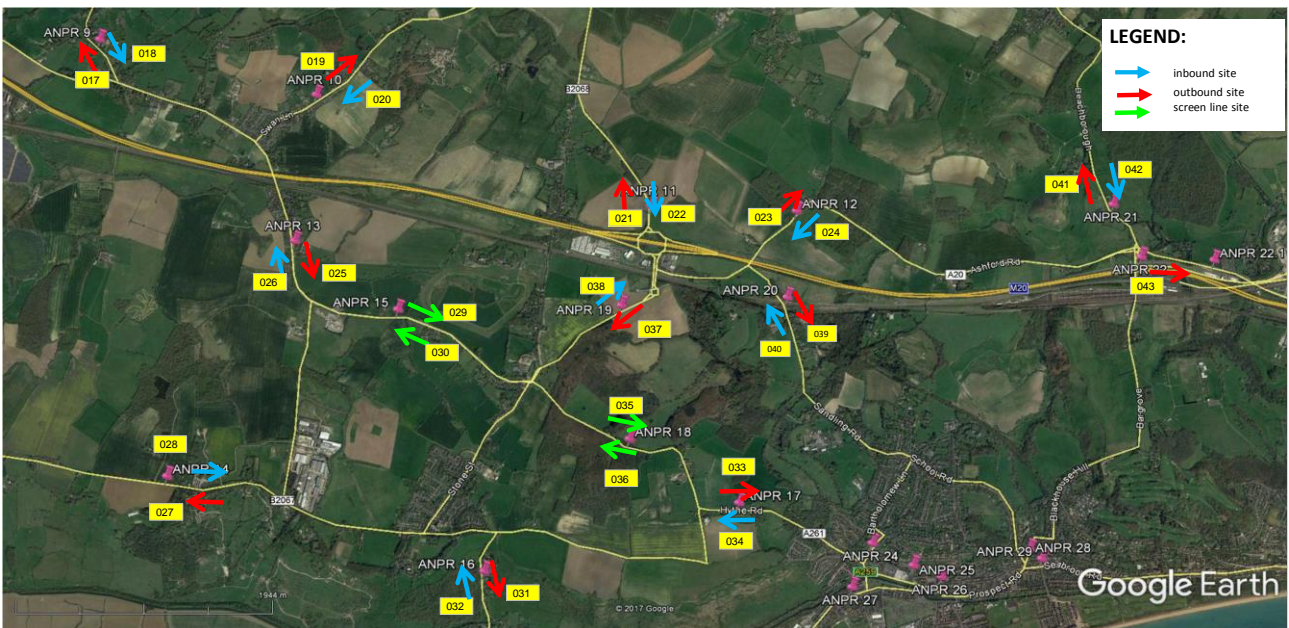

Otterpool Park Garden Settlement
Traffic Survey Data Analysis



APPENDIX B

Classified Turning Counts (Summary)

Time (Starting hour)	PERIOD	HOURLY FLOWS										
		CAR	TAXI	LGV	OGV 1	OGV 2	BUS	COACH	MCY	PCY	TOTAL	Only motorised
07:00	AM	35,628	4	7,507	948	1,149	279	365	326	109	46,315	46,206
07:15		41,688	4	7,855	1,007	1,103	309	400	316	103	52,785	52,682
07:30		46,670	4	7,695	1,124	1,092	300	398	317	90	57,690	57,600
07:45		49,727	4	7,325	1,239	1,071	259	398	296	68	60,387	60,319
08:00		50,382	8	6,728	1,298	1,061	247	419	285	71	60,499	60,428
08:15		47,750	16	6,376	1,341	1,091	220	405	274	61	57,534	57,473
08:30		43,788	19	6,134	1,349	1,196	243	404	236	69	53,438	53,369
08:45		38,681	23	5,933	1,285	1,174	228	388	242	74	48,028	47,954
09:00		34,639	22	5,803	1,333	1,196	234	385	222	111	43,945	43,834
09:15	Off Peak*	23,296	13	3,647	873	601	165	306	146	94	29,141	29,047
09:30		22,581	10	3,520	884	541	172	289	153	85	28,235	28,150
09:45		22,617	10	3,412	948	551	178	264	142	81	28,203	28,122
10:00		22,591	8	3,412	903	546	162	211	177	57	28,067	28,010
10:15		22,690	8	3,433	884	550	165	205	173	71	28,179	28,108
10:30		23,129	9	3,437	881	548	156	200	164	79	28,603	28,524
10:45		23,322	7	3,457	861	514	164	209	153	84	28,771	28,687
11:00		23,492	5	3,363	845	469	169	213	118	71	28,745	28,674
11:15		23,934	4	3,398	799	442	168	222	143	61	29,171	29,110
11:30		24,055	5	3,458	826	460	172	216	164	48	29,404	29,356
11:45		24,223	5	3,475	780	480	164	203	161	38	29,529	29,491
12:00		24,459	10	3,470	772	492	174	212	170	28	29,787	29,759
12:15		24,618	10	3,399	766	516	168	217	157	41	29,892	29,851
12:30		24,496	12	3,335	719	499	155	237	158	64	29,675	29,611
12:45		24,537	16	3,384	748	484	160	240	188	93	29,850	29,757
13:00		24,432	17	3,449	773	501	163	225	202	99	29,861	29,762
13:15		24,464	22	3,601	826	511	167	259	194	94	30,138	30,044
13:30		25,300	25	3,657	819	516	171	276	176	95	31,035	30,940
13:45		25,981	19	3,637	760	518	181	308	147	85	31,636	31,551
14:00		26,721	16	3,713	702	535	173	330	131	92	32,413	32,321
14:15		27,406	13	3,748	631	513	176	304	179	92	33,062	32,970
14:30	27,939	11	3,816	632	518	184	327	182	76	33,685	33,609	
14:45	28,381	16	3,991	658	513	169	312	207	70	34,317	34,247	
15:00	28,692	17	4,046	655	502	176	316	216	58	34,678	34,620	
15:15	30,528	17	4,522	612	493	210	320	220	62	36,984	36,922	
15:30	31,059	14	4,798	578	505	189	280	276	58	37,757	37,699	
15:45	32,070	13	4,895	510	487	187	280	319	57	38,818	38,761	
16:00	PM	45,692	9	7,390	842	972	229	383	460	80	56,057	55,977
16:15		48,534	7	7,215	781	958	224	361	483	92	58,655	58,563
16:30		51,190	5	6,912	654	889	216	330	482	102	60,780	60,678
16:45		53,046	1	6,442	546	888	227	295	495	109	62,049	61,940
17:00		54,260	2	5,861	497	862	232	278	529	125	62,646	62,521

Otterpool Park Garden Settlement
 Traffic Survey Data Analysis

Time (Starting hour)	PERIOD	HOURLY FLOWS										
		CAR	TAXI	LGV	OGV 1	OGV 2	BUS	COACH	MCY	PCY	TOTAL	Only motorised
17:15		51,968	2	5,131	464	827	220	282	507	134	59,535	59,401
17:30		48,408	2	4,467	457	858	222	280	437	139	55,270	55,131
17:45		43,992	1	3,825	420	829	205	270	405	142	50,089	49,947
18:00		39,956	-	3,298	377	796	171	233	391	134	45,356	45,222

* Surveys conducted in 2016 did not include Off Peak hours.

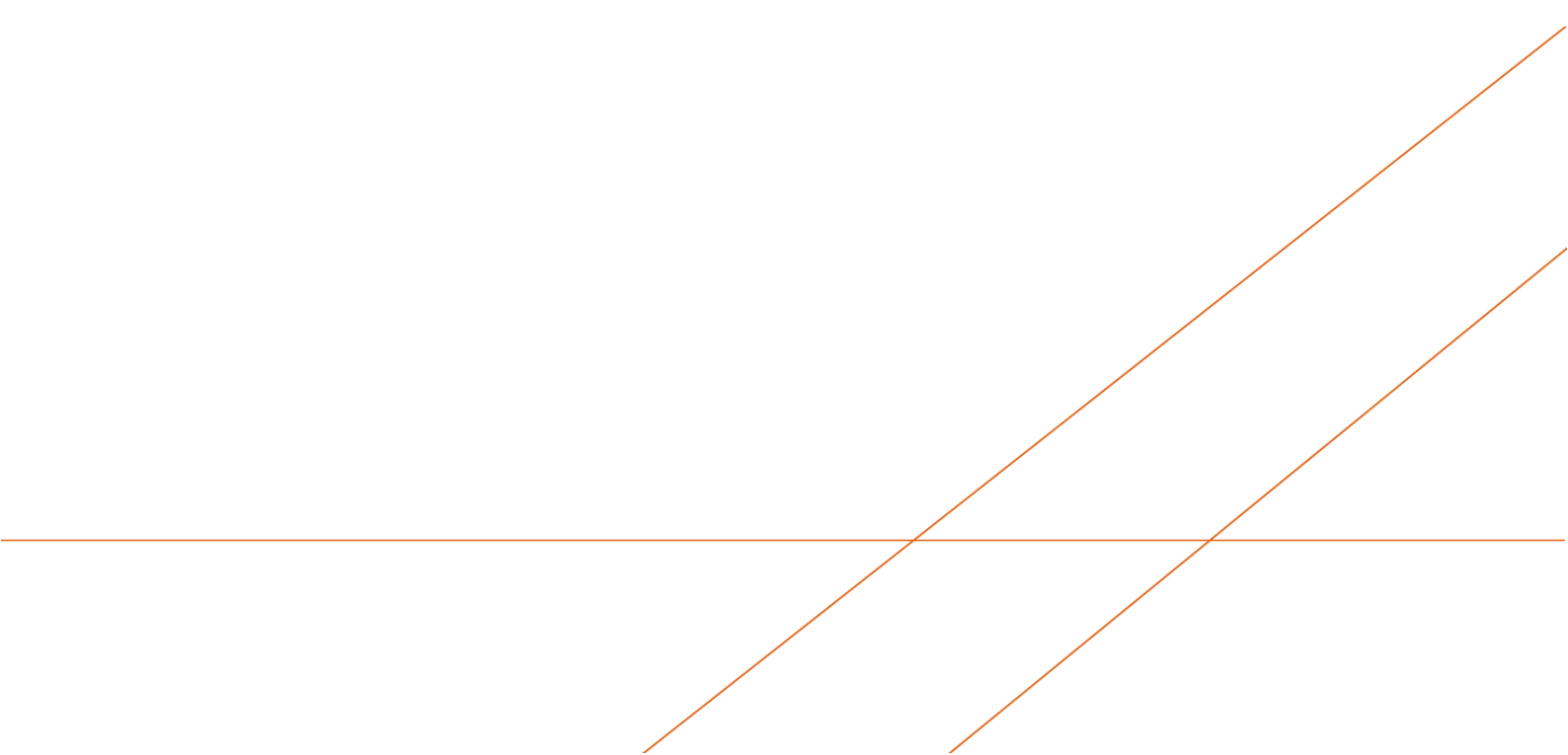

APPENDIX B

Signal data. Electronic appendices

Junction No.	Junction location	File name
1	M20 J10	J1 M20 J10.zip
9	A20 Ashford Road / B2067 Otterpool Lane	J9 A20 Ashford Rd B2067 Otterpool Ln.zip
16	A259 / Dymchurch Road / Military Road	J16 A259-Dymchurch Rd-Military Rd_gyratory.zip
24	B2064 Cheriton High Street / B2063 Risborough Lane	J24 B2064 Cheriton High Street B2063 Risborough Ln.zip
25	B2064 Cheriton High Street / A2034 Cherry Garden Avenue	J25 B2064 Cheriton High St Cherry Garden Ave.zip
27	M20 J9	J27 M20 Junction 9.zip

APPENDIX C

LinSig. Electronic appendices

Junction No.	Junction location	File name
1	M20 J10	J1 M20 Junction 10.pdf
9	A20 Ashford Road / B2067 Otterpool Lane	J9 A20 Ashford Rd - Otterpool Ln.pdf
16	A259 / Dymchurch Road / Military Road	J16 Scalons Bridge Rd-Military Rd-Dymchurch Rd.pdf
24	B2064 Cheriton High Street / B2063 Risborough Lane	J24 Cheriton High Str-Risborough Ln.pdf
25	B2064 Cheriton High Street / A2034 Cherry Garden Avenue	J25 B2064 Cheriton High street-A2034 Cherry Garden avenue.pdf
27	M20 J9	J27_M20_Junction9.pdf

APPENDIX D

ARCADY. Electronic appendices

Junction No.	Junction location	File name
2	M20 J11	J2 M20-J11-B2048-A20-AM_Peak.pdf
		J2 M20-J11-B2048-A20-PM_Peak.pdf
8	Hythe Road (A20) / The Street	J8 A20 Hythe Rd.The St.AM Peak.pdf
		J8 A20 Hythe Rd.The St.PM Peak.pdf
20	A259 Prospect Road / A259 Seabrook Road / Station Road / High Street	J20 A259-Prospect Rd-Station Rd_AM Peak.pdf
		J20 A259-Prospect Rd-Station Rd_PM Peak.pdf
21	M20 J11A	J21 A20 Ashford Rd-Bargrove AM.pdf
		J21 A20 Ashford Rd-Bargrove PM.pdf
22	M20 J12	J22 M20-J12 Cheriton Interchange_AM PEAK.pdf
		J22 M20-J12 Cheriton Interchange_PM PEAK.pdf
23	M20 J13	J23A M20 J13 Castle Hill Interchange am Peak.pdf
		J23A M20 J13 Castle Hill Interchange pm Peak.pdf
		J23B M20 J13 Castle hill Interchange AM.pdf
		J23B M20 J13 Castle hill Interchange PM.pdf
28	A260 Spitfire Way / White Horse Hill / A20 Slip Roads	J28 A20 Slip road Spitfire Way Canterbury Rd am.pdf
		J28 A20 Slip road Spitfire Way Canterbury Rd pm.pdf
29	Alkham Valley Road / A20 slip roads	J29 Alkham Valley Rd A20 Slip am.pdf
		J29 Alkham Valley Rd A20 Slip pm.pdf

APPENDIX E

PICADY. Electronic appendices

Junction No.	Junction location	File name
3	Ashford Road (A20) / Swan Lane	J3-A20 Ashford Rd - Swan Ln_Base Model.pdf
4	Ashford Road (A20) / Stone Hill	J4 A20 Ashford Rd - Stone Hill.pdf
5	Ashford Road (A20) / Station Road / Church Road	J5 A20-Station Rd-Church Rd_Base Model.pdf
6	Hythe Road (A20) / Mersham	J6 A20-Mersham_Base Model.pdf
7	A2070 Kenniton Road / The Street	J7 Kennington Rd - The Street.pdf
10	B2067 Otterpool Lane / Aldington Road	J10 B2067 Otterpool Ln - Aldington Rd_Base Model.pdf
11	Aldington Road / Stone Street	J11 Aldington Rd - Stone St_Base Model.pdf
12	A20 Ashford Road / A261 Hythe Road / Stone Street	J12 A20_Stone Street output.pdf
		J12 A20_Hythe Road output.pdf
13	Aldington Road / Lypmne Hill	J13 Aldington Rd - Lypmne Hill_Base Model.pdf
14	A261 Hythe Road / Aldington Road	J14 A261 Hythe Rd - Aldington Rd_Base Model
15	A261 London Road / Barrack Hill	J15 A261 London Rd - Barrack Hill_Base Model.pdf
17	A20 Ashford Road / A20 J11 offslip	J17 A20 - Ashford Rd_Base Model.pdf
18	Ashford Road (A20) / Sandling Road	J18 A20 - Sandling Rd_Base Model.pdf
19	A20 Ashford Road / Stone Street	J19 A20 Ashford Rd - Stone St_Base Model.pdf
26	A259 Prospect Road / Stade Street	J26 Prospect Rd - Stade St_Base Model.pdf
30	A260 Canterbury Road / Alkham Valley Road	J30 Canterbury 20Rd-A260-Alkham am.pdf
		J30 Canterbury 20Rd-A260-Alkham pm.pdf

Arcadis (UK) Limited

Arcadis House
34 York Way
London N1 9AB
United Kingdom
T: +44 (0)20 7812 2000

[arcadis.com](https://www.arcadis.com)



APPENDIX E – 2018 Baseline flow diagrams

E.1 Folkestone & Hythe and Ashford - 2018 AM Peak

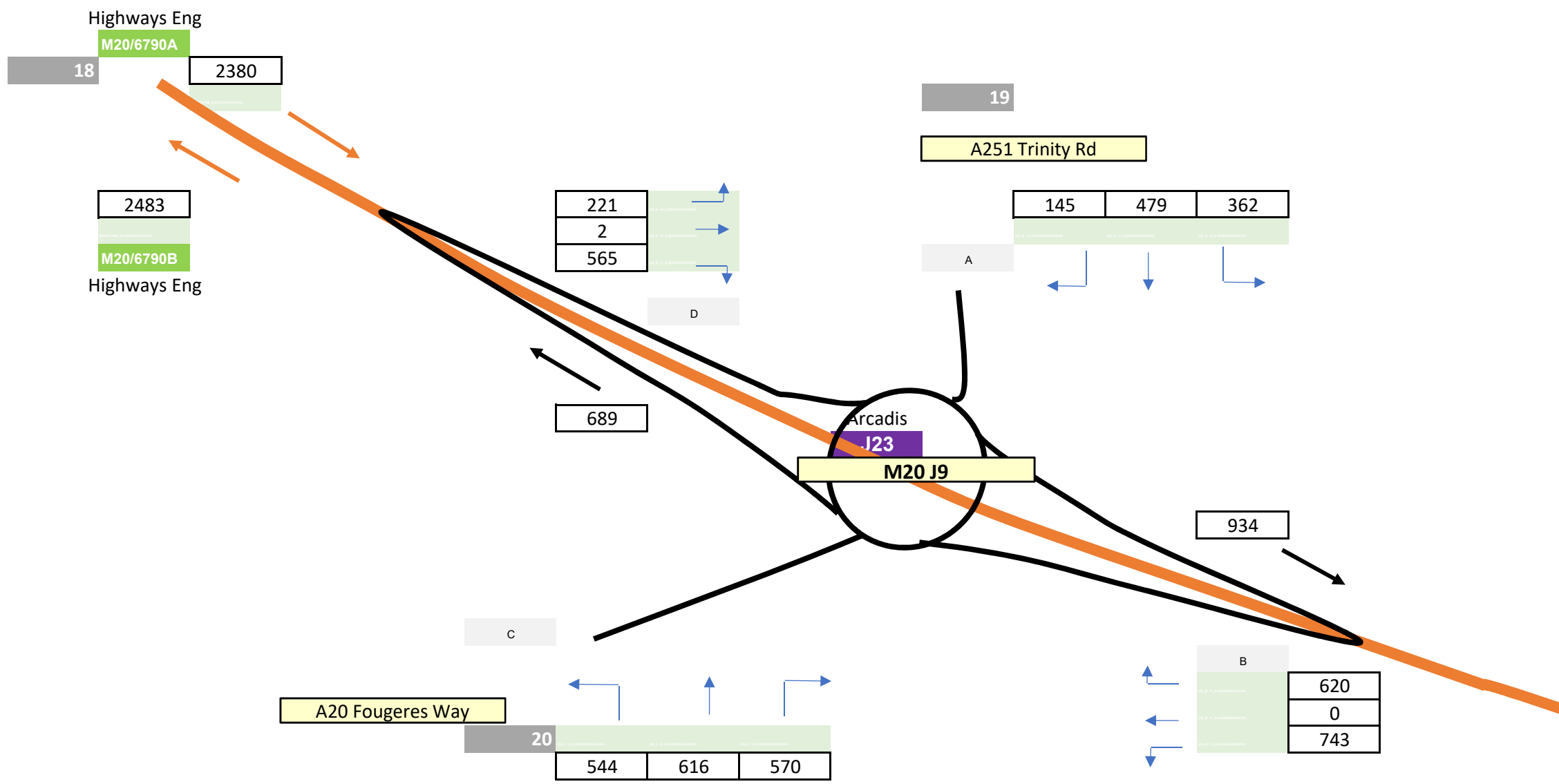

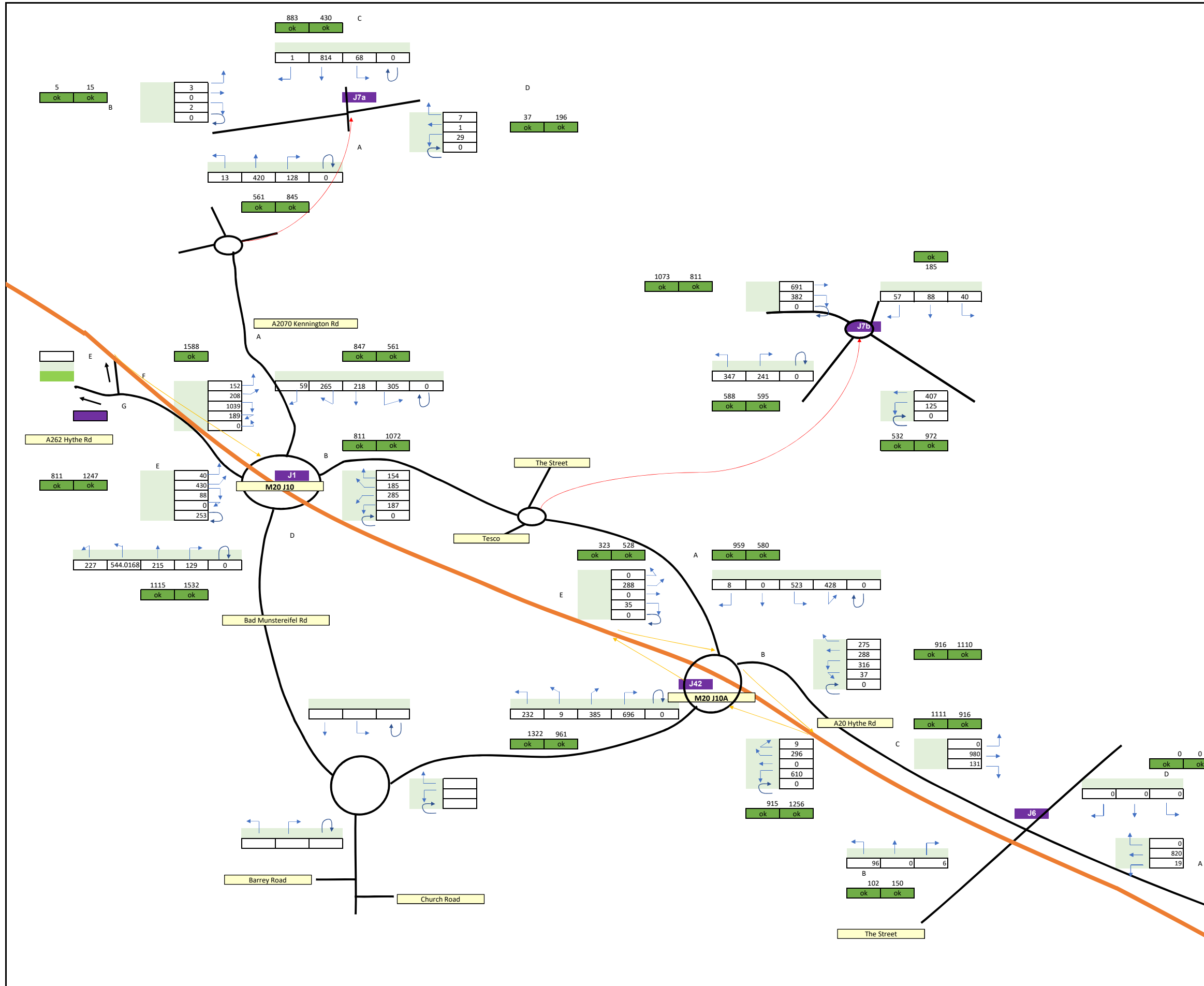

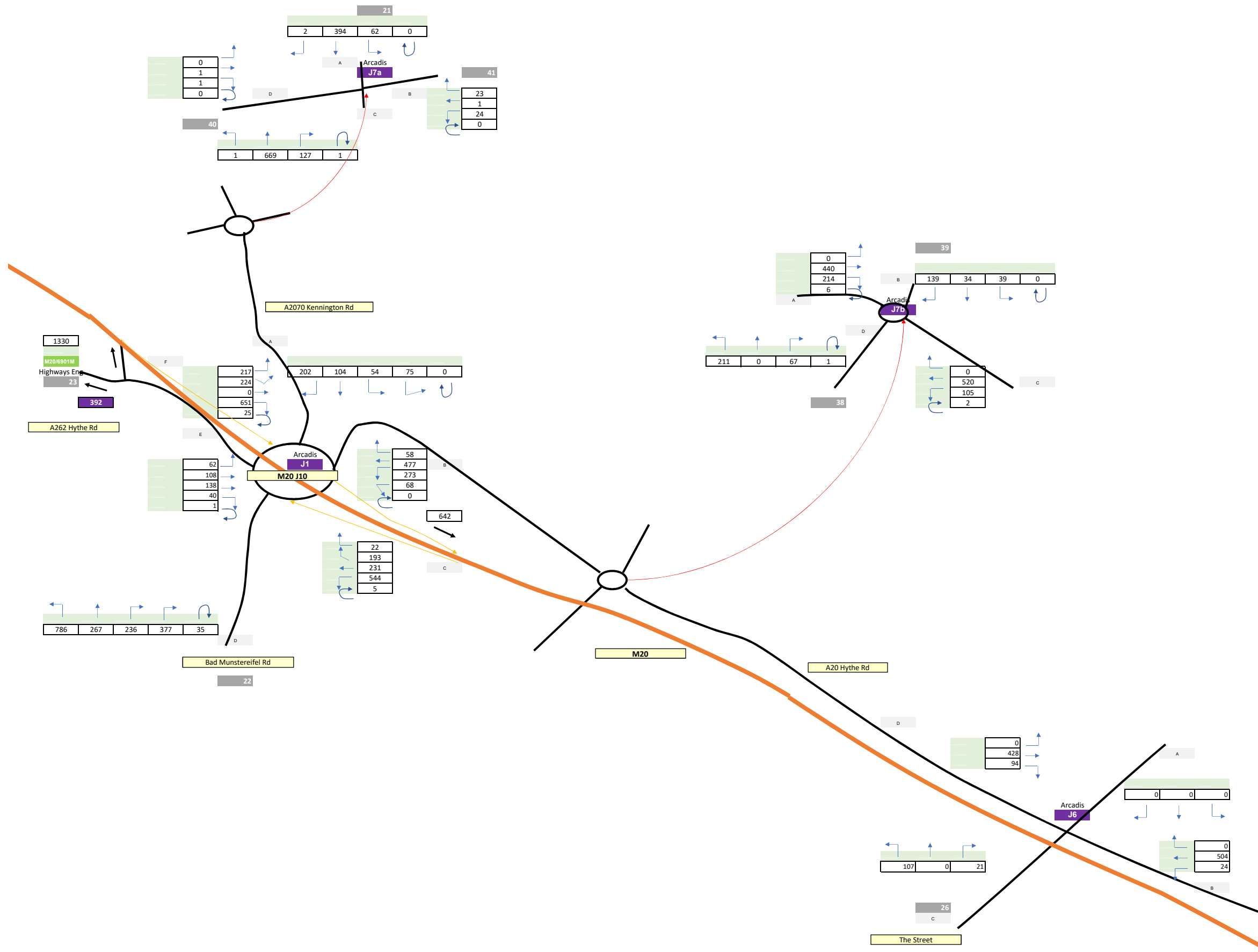

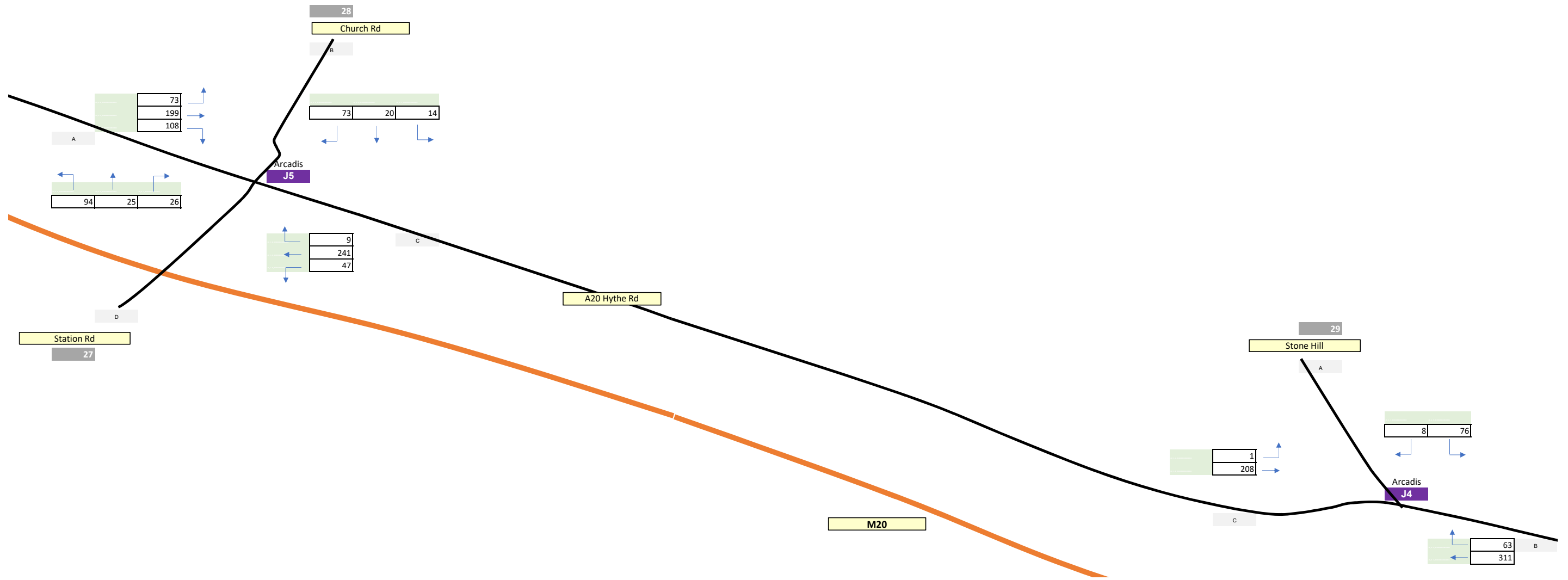

53

Swan Lane

A

102 | 0 | 42

Aecom

J3

← ↓ ↘

5 | 0 | 2

c

24
290
0

D

Barrow Hill

A

B

74
214
2

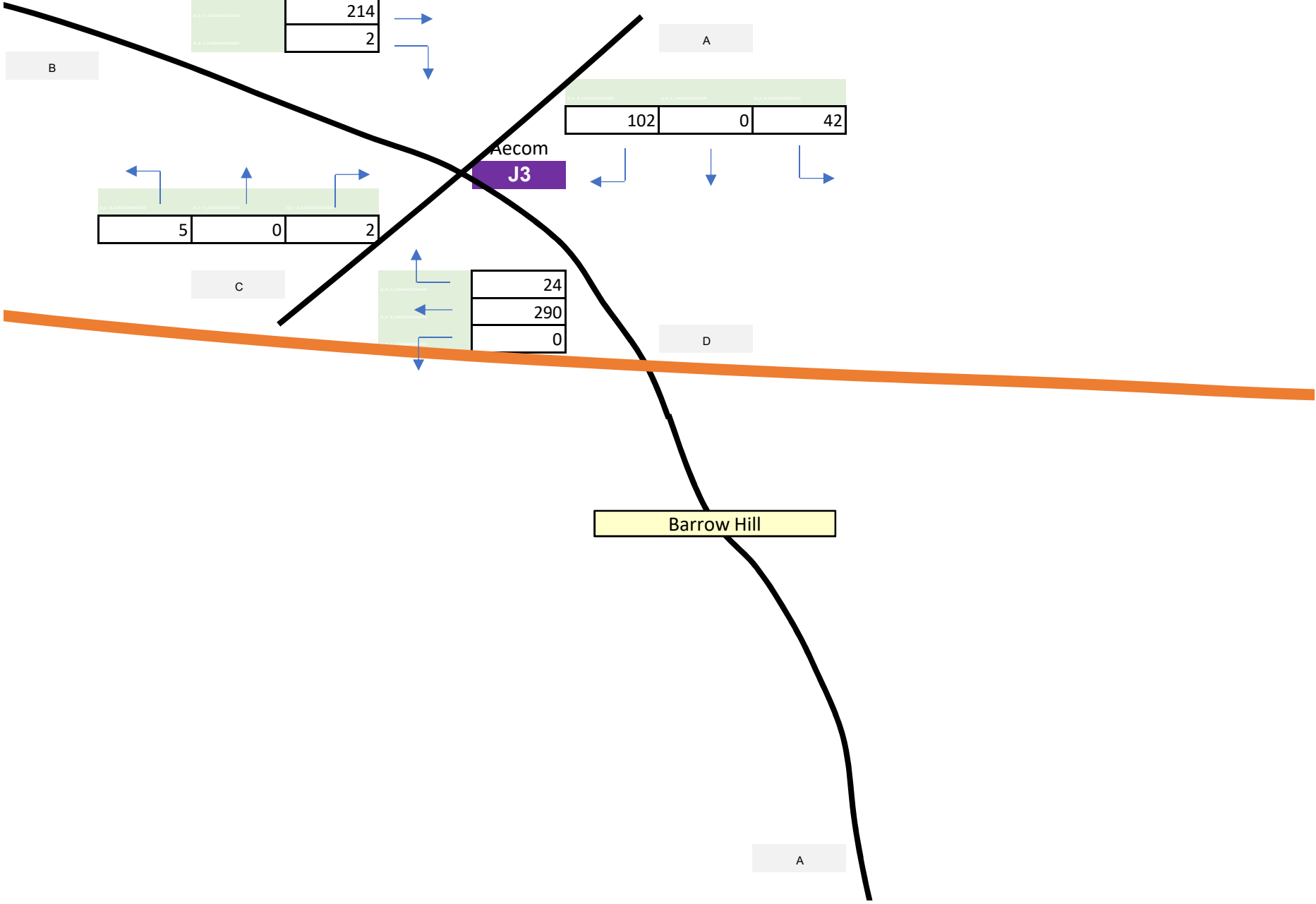
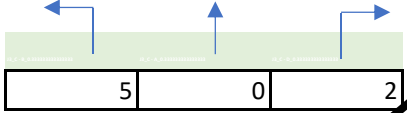
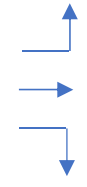

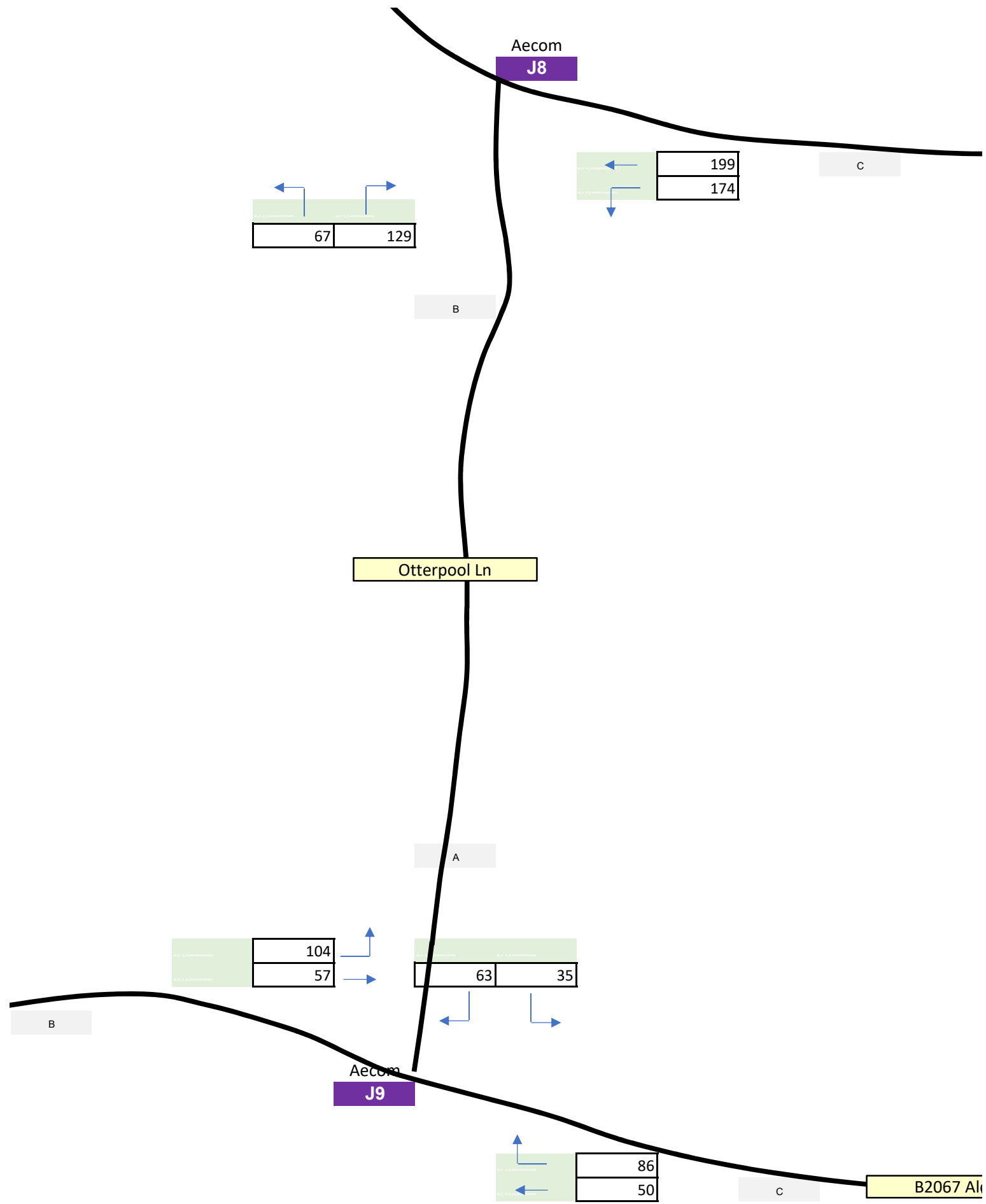

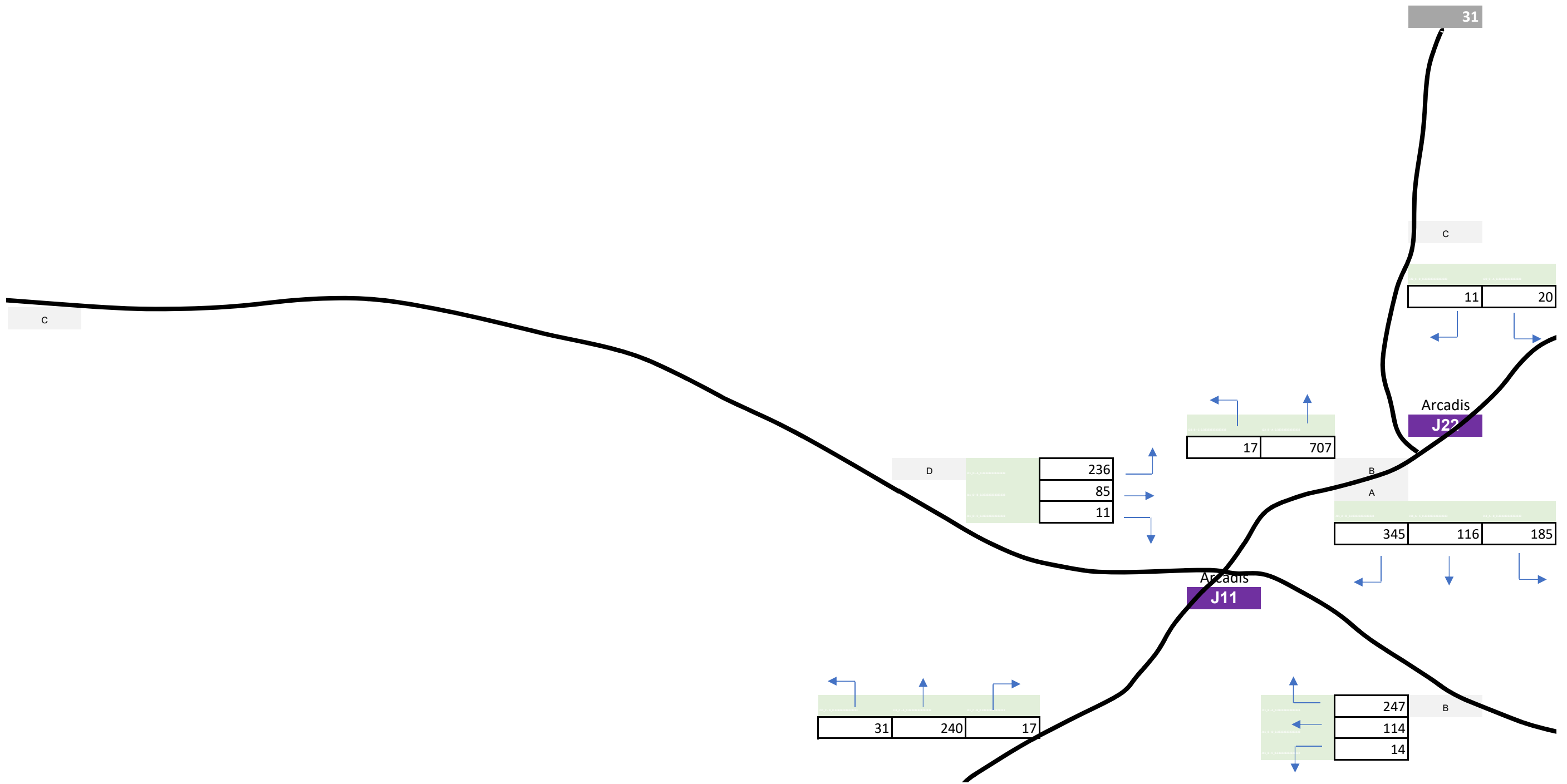

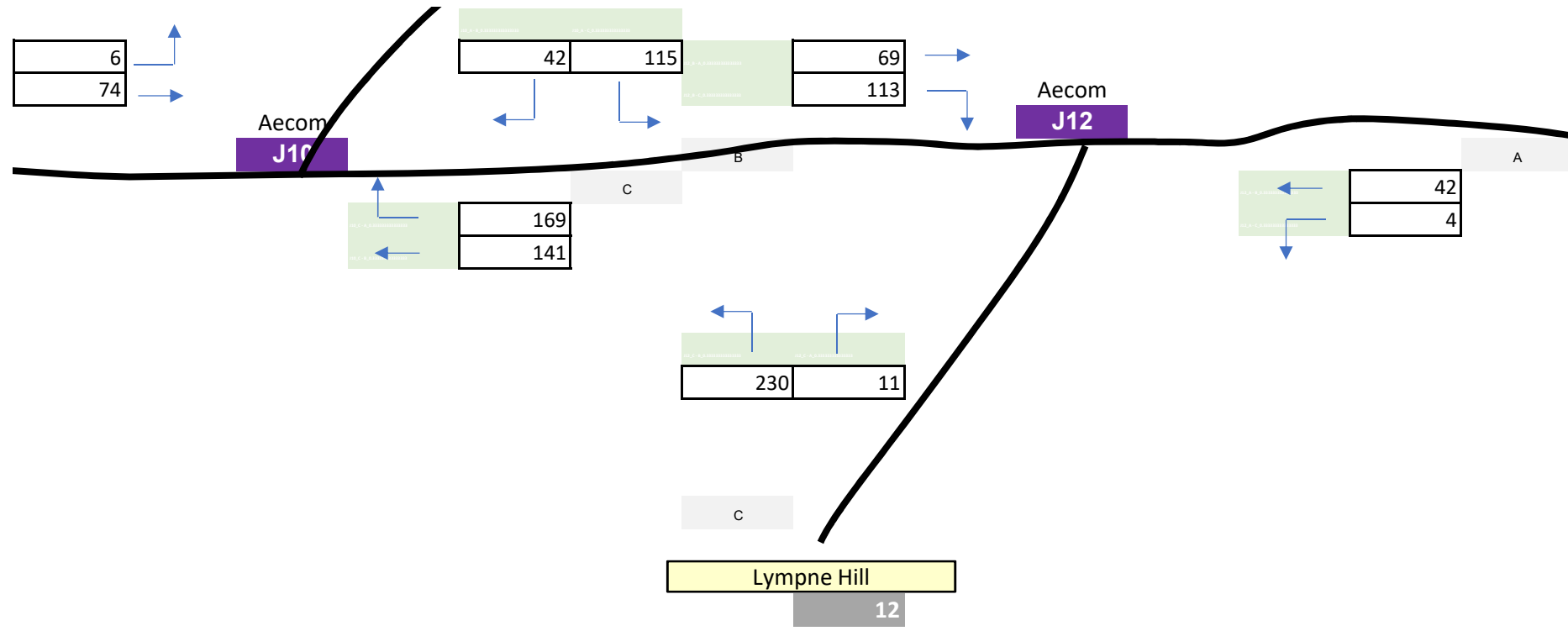

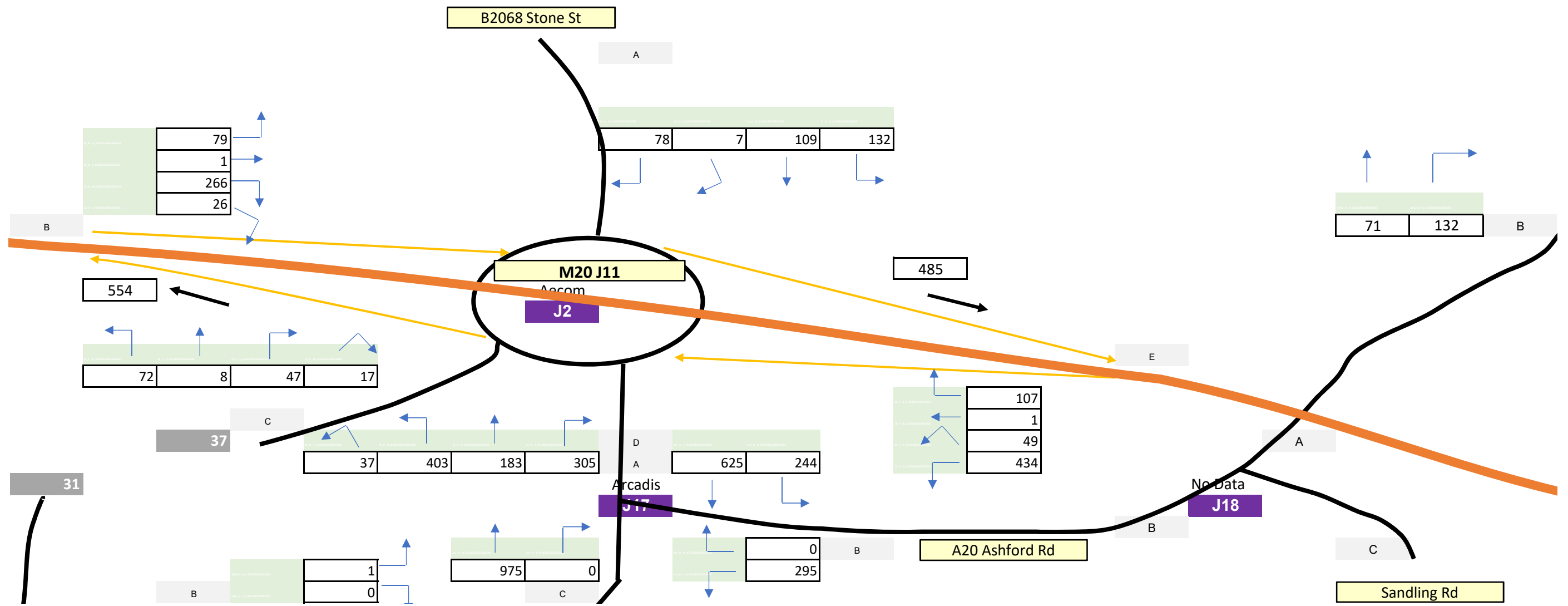

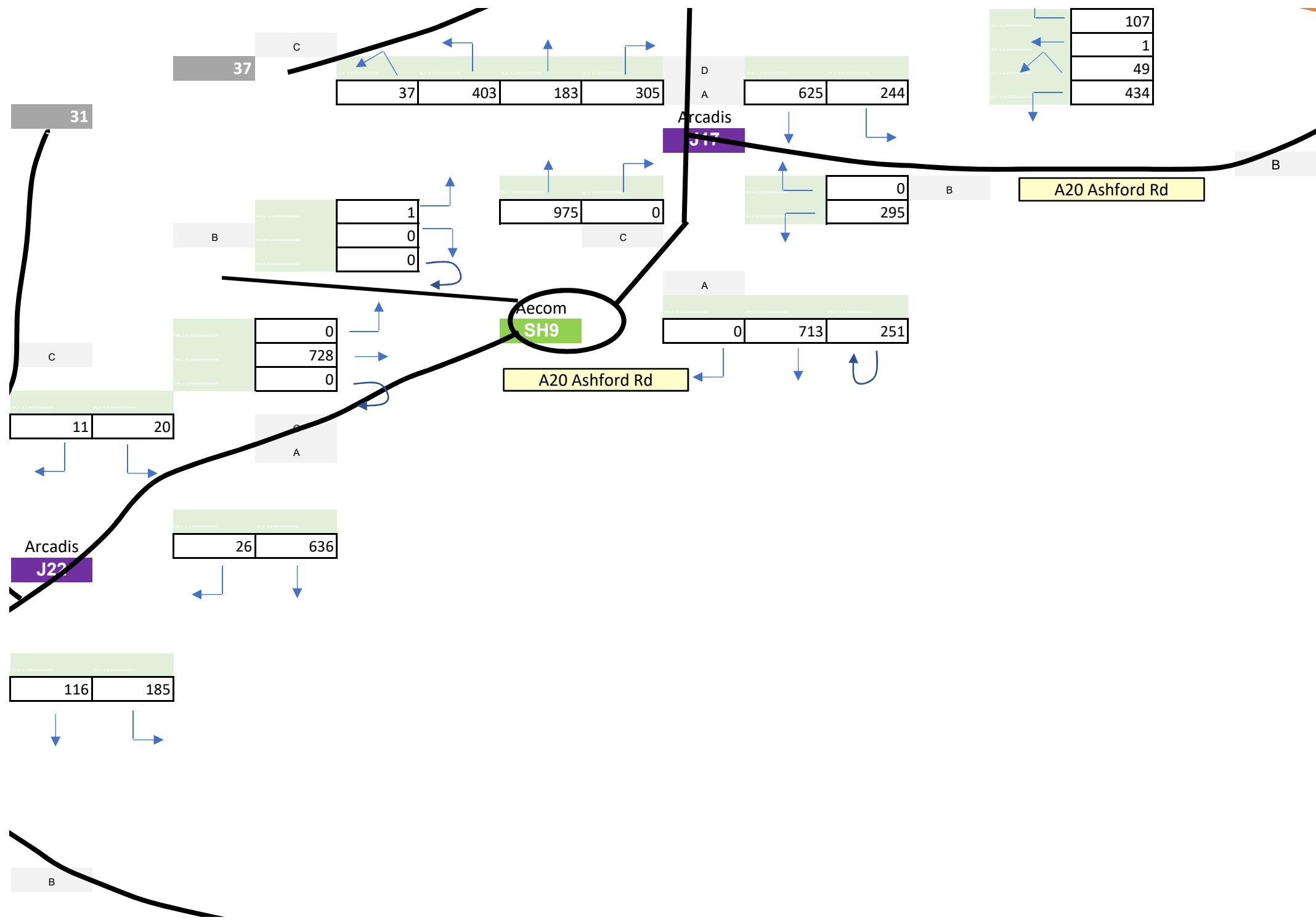

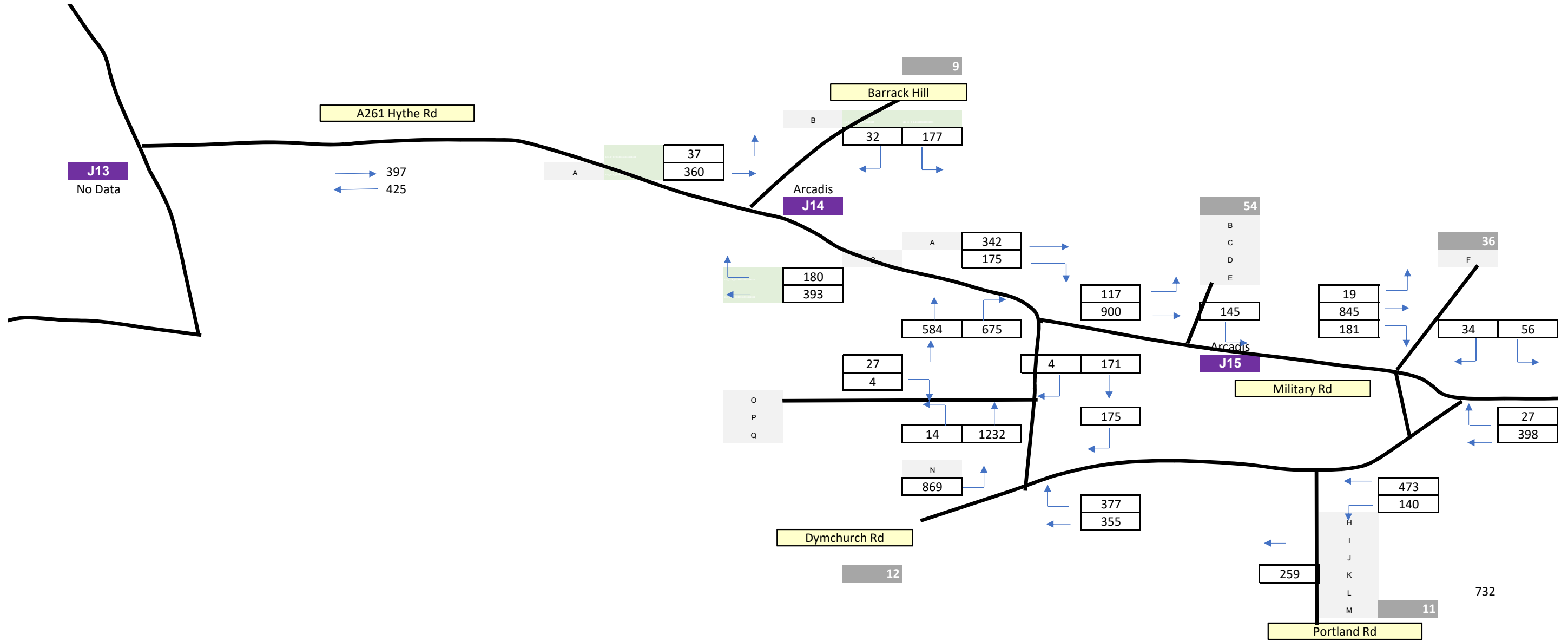

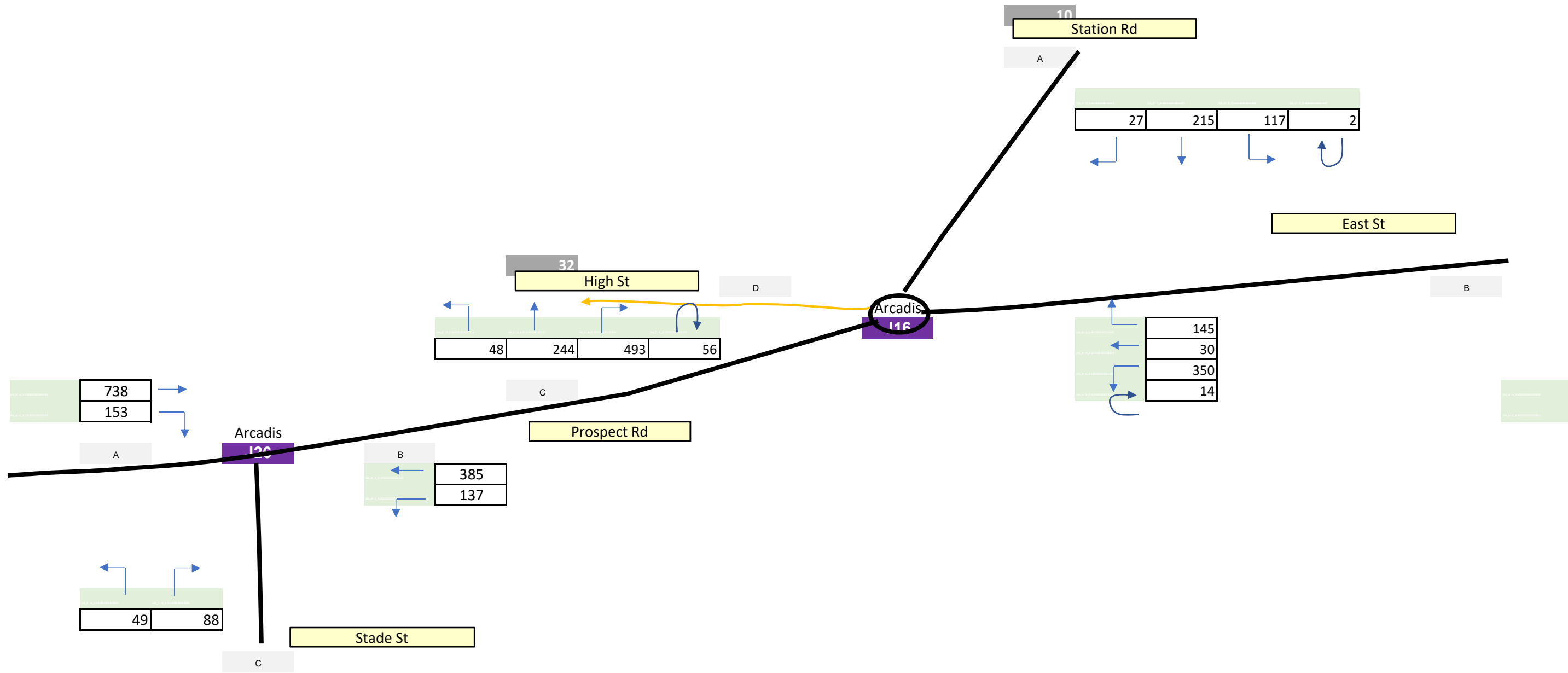

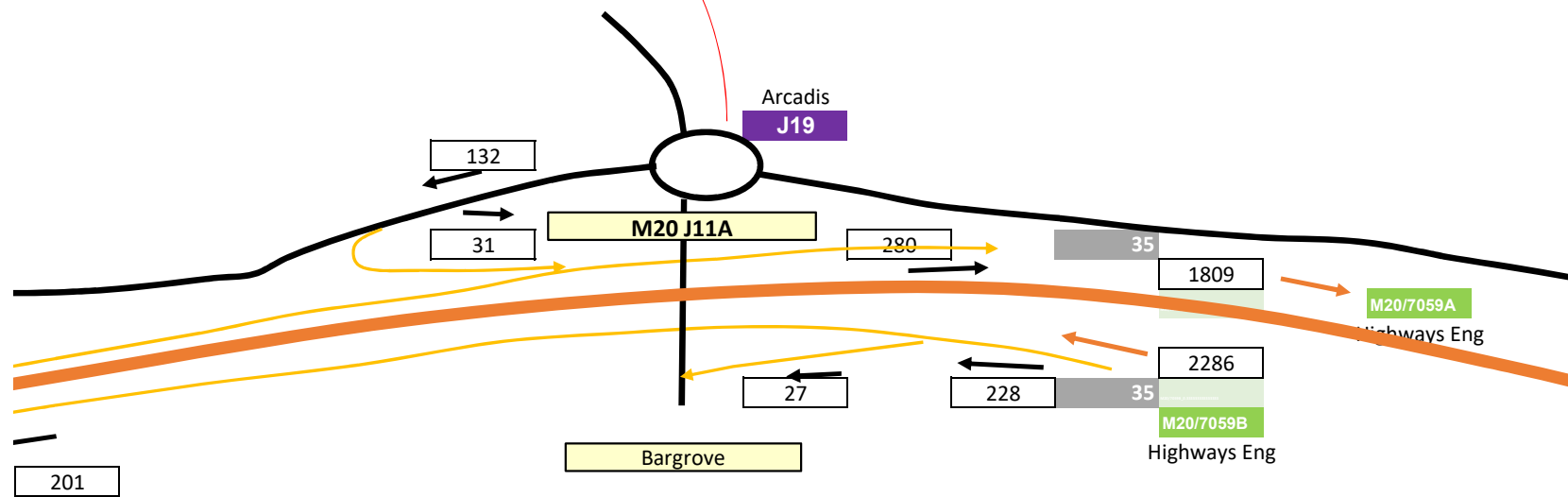
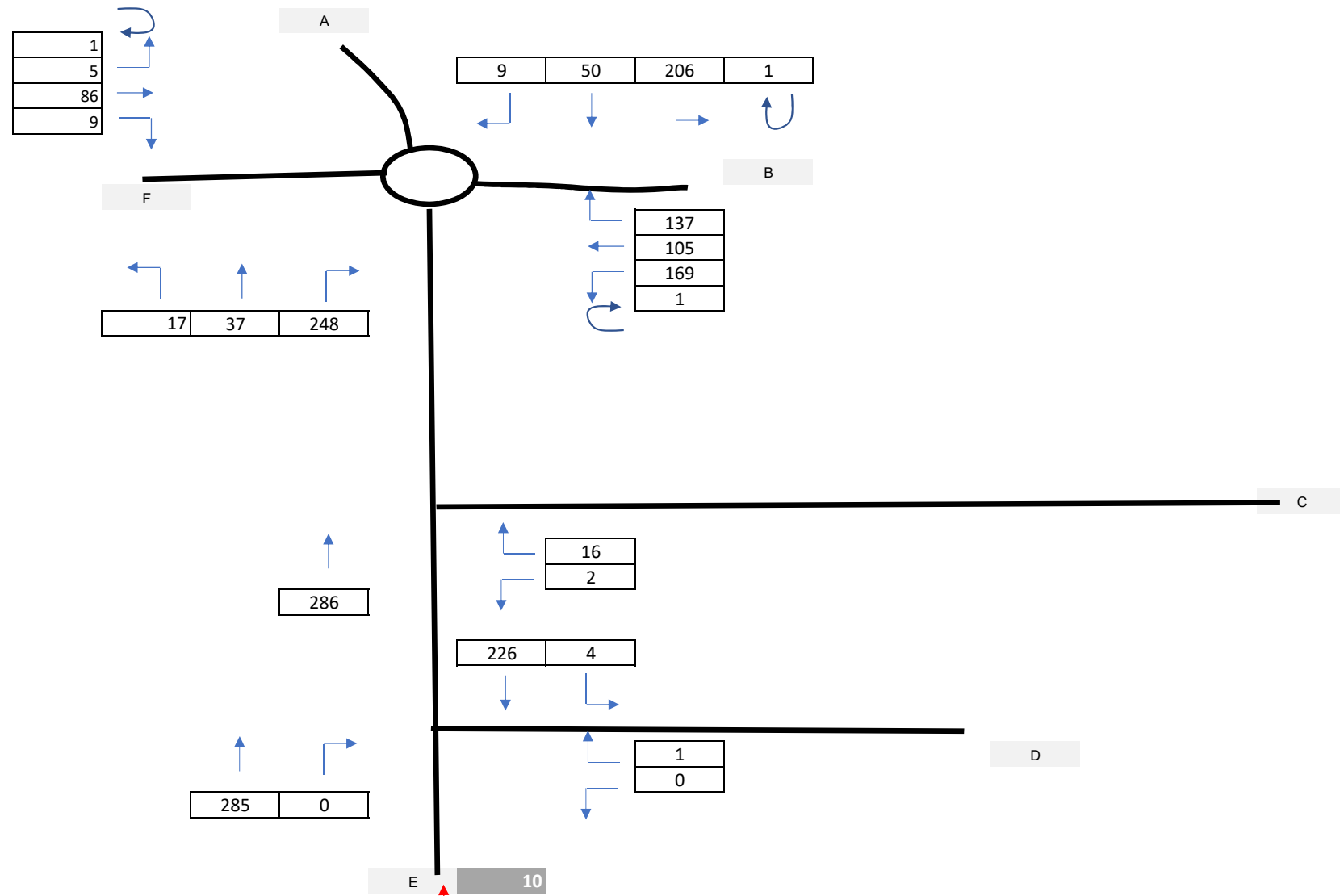

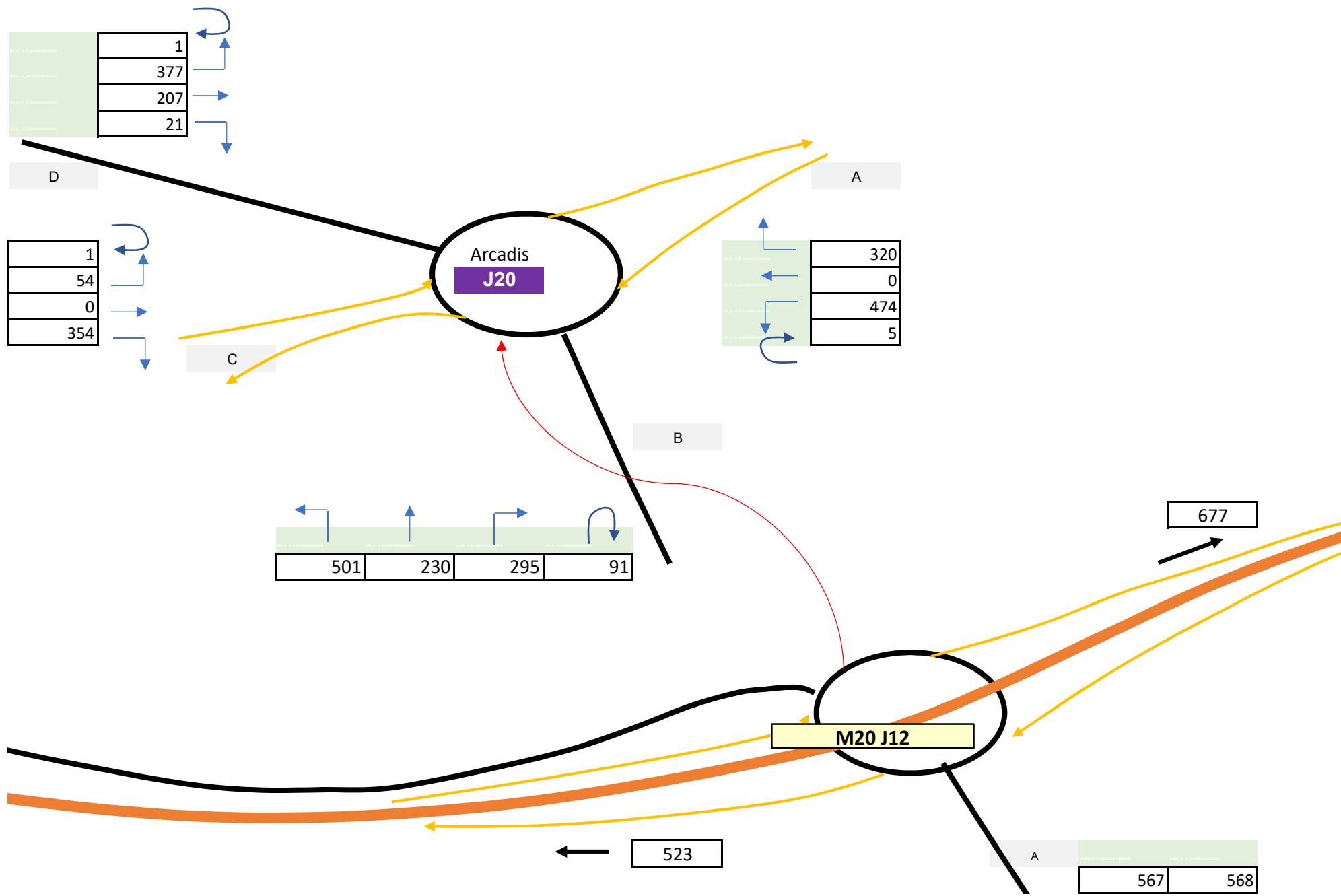

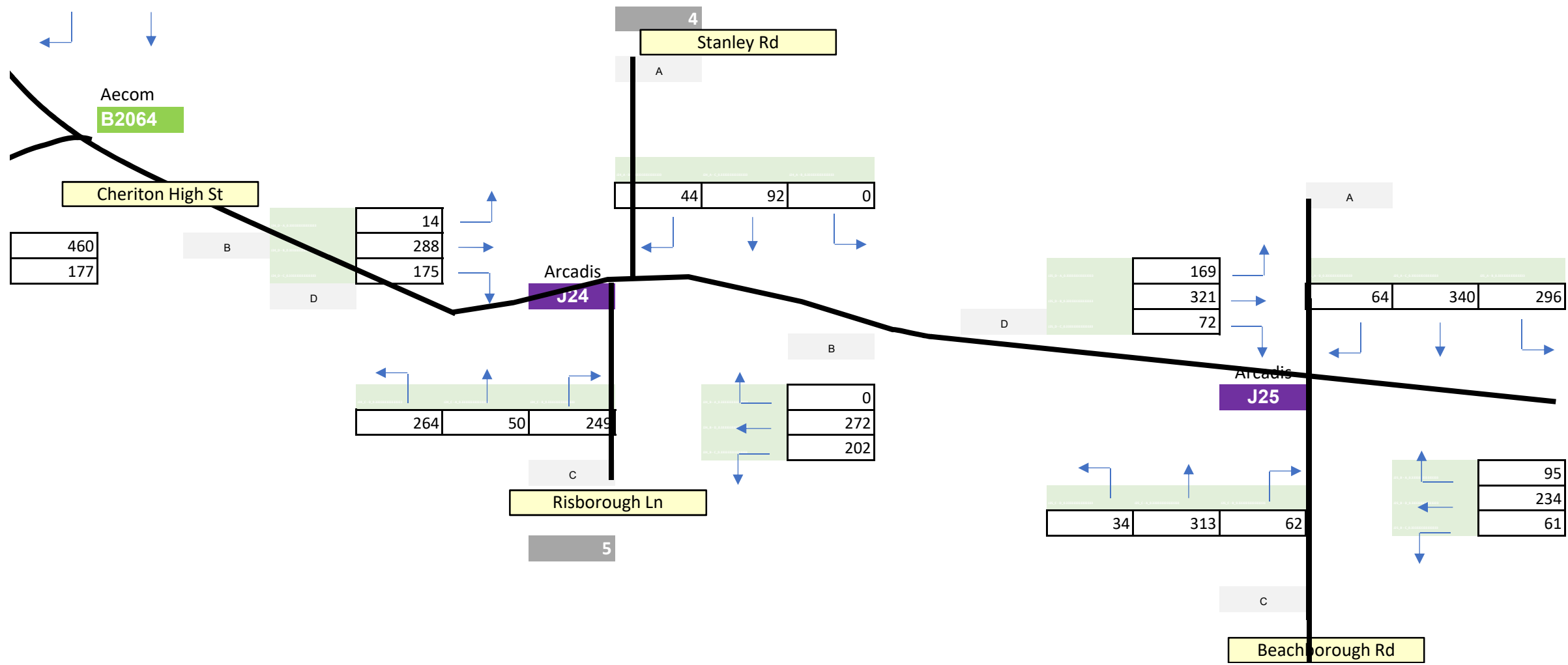

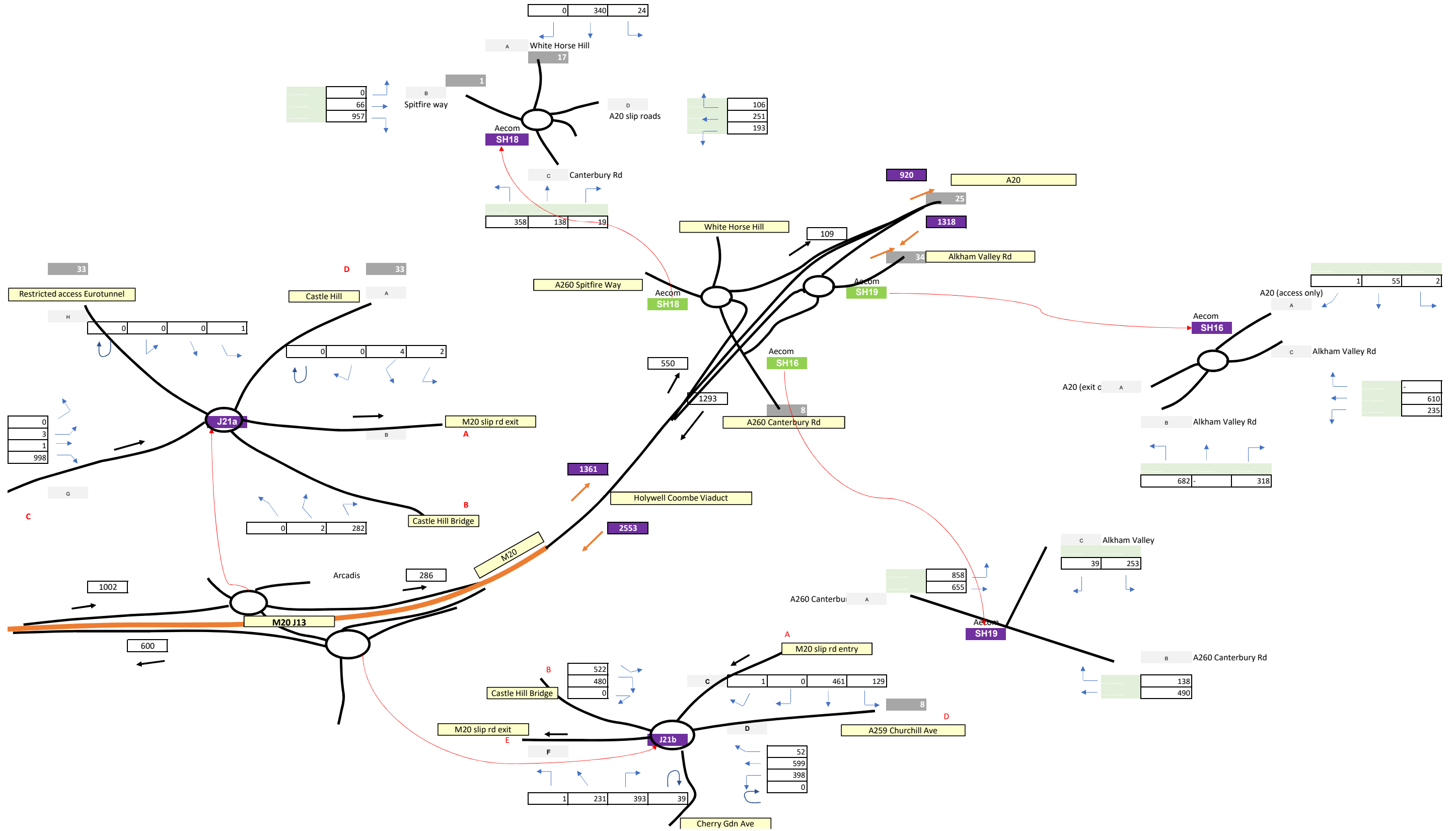

E.2 Folkestone & Hythe and Ashford - 2018 PM Peak

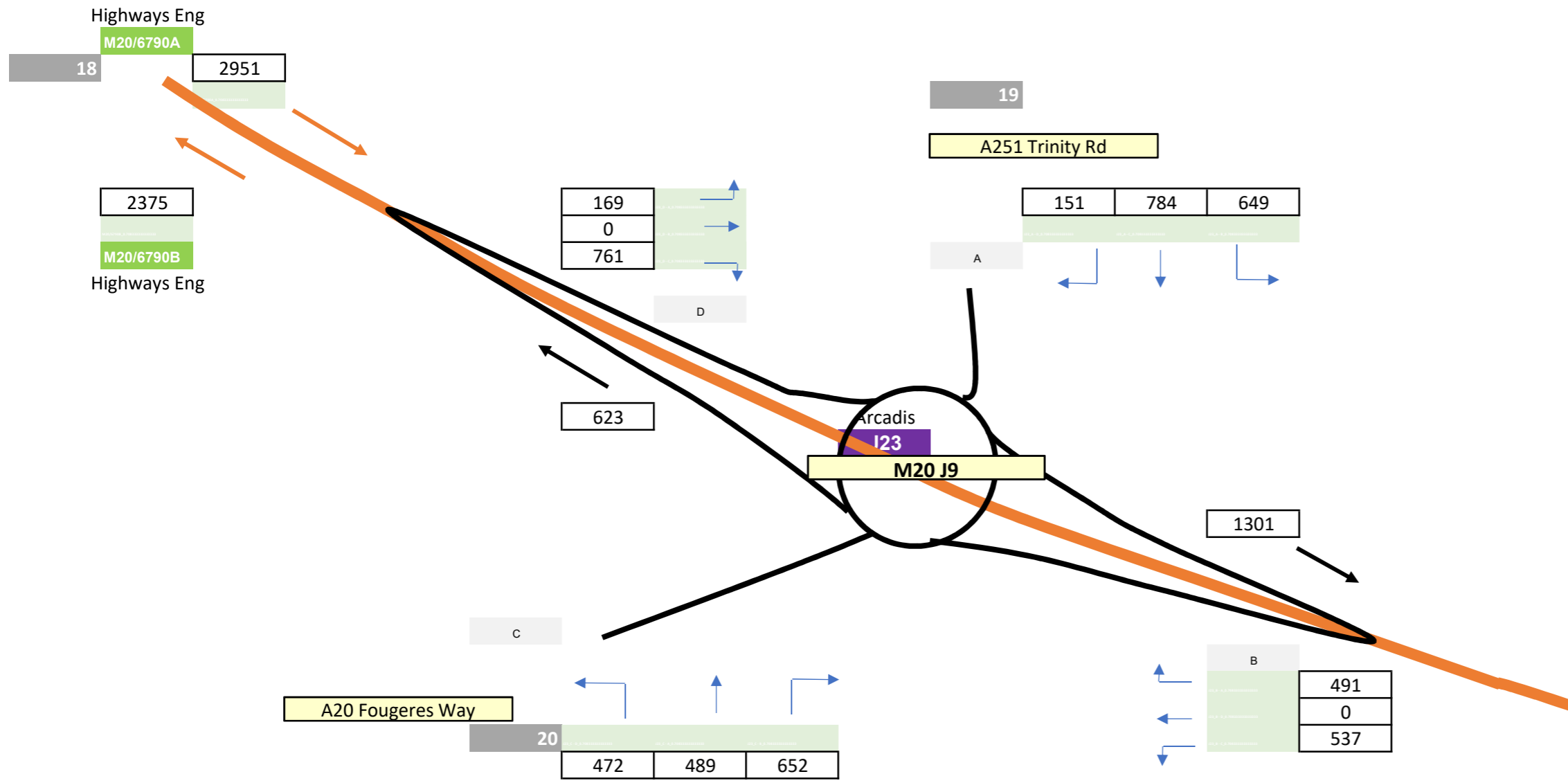

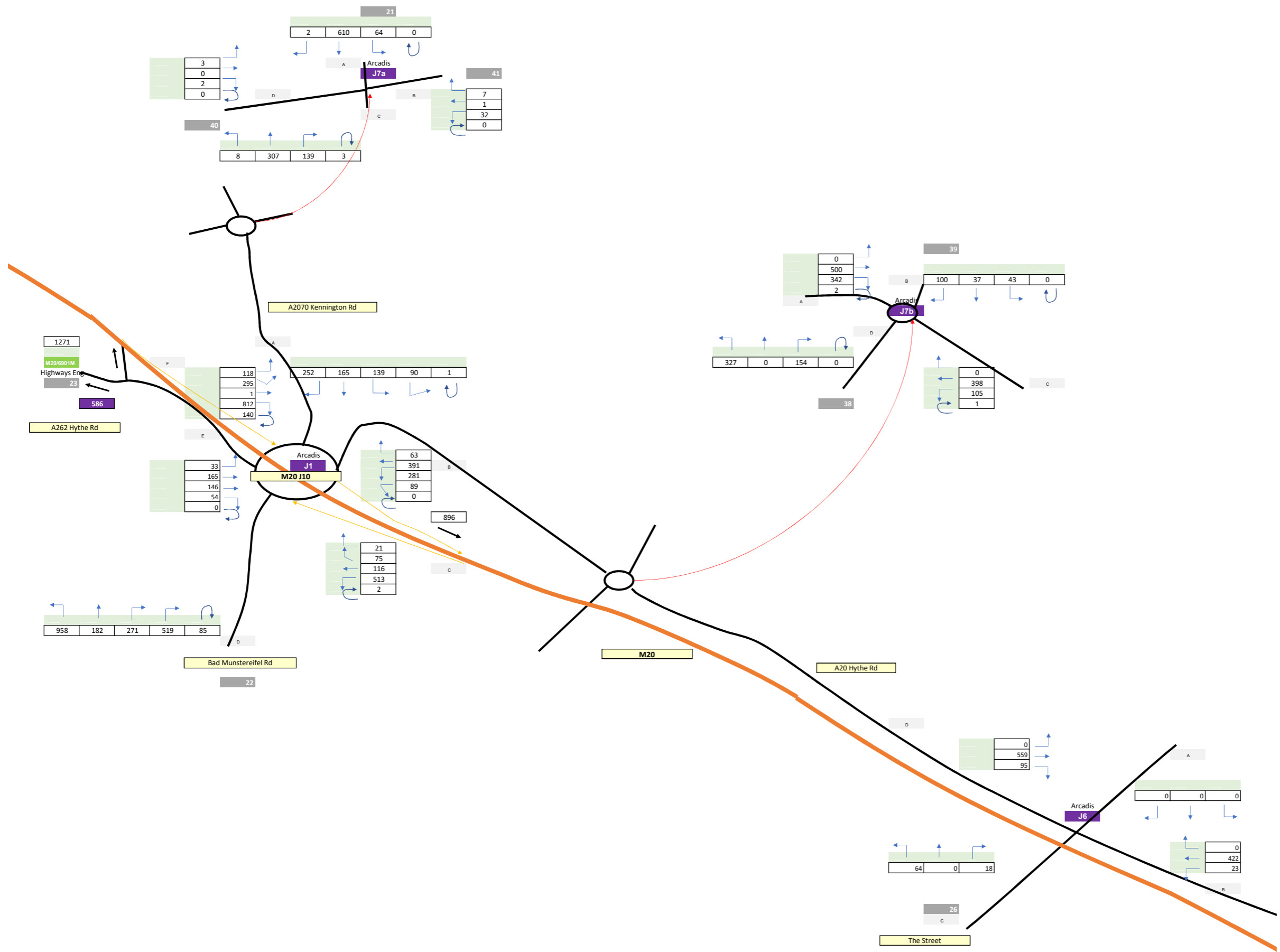

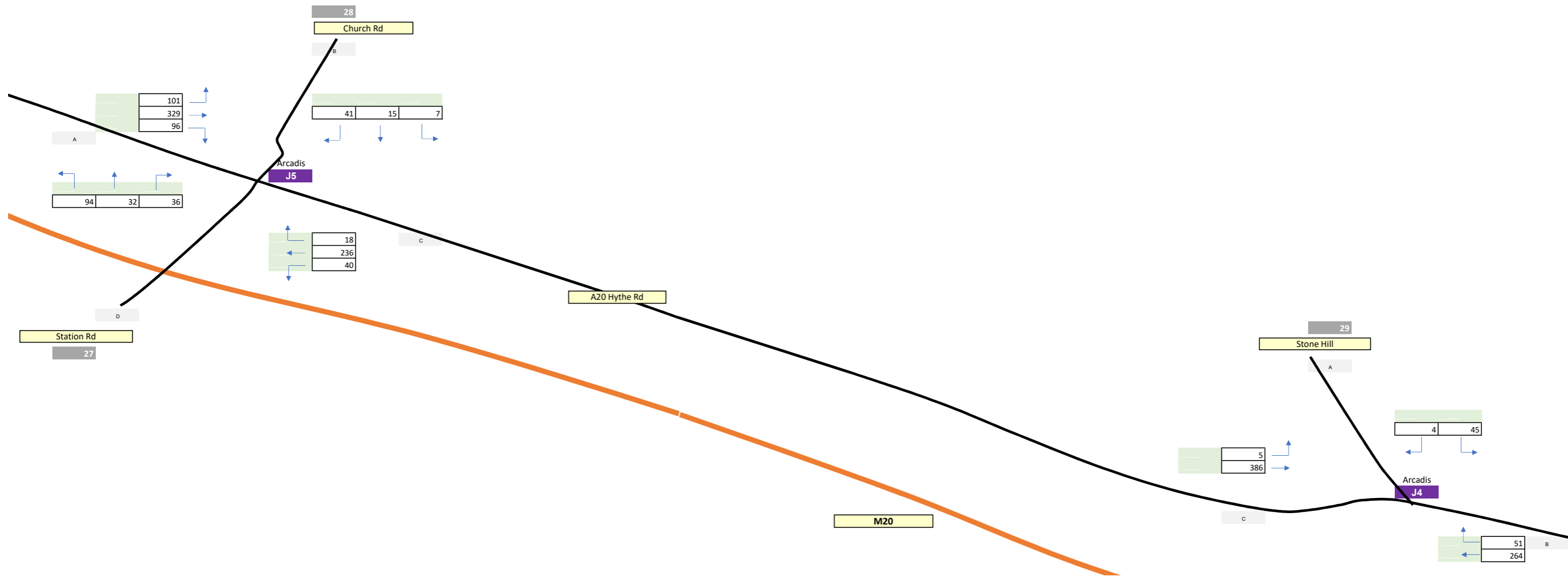

53

Swan Lane

A

71 0 34

Aecom
J3

1 0 1

c

58
211
2

D

Barrow Hill

A

B

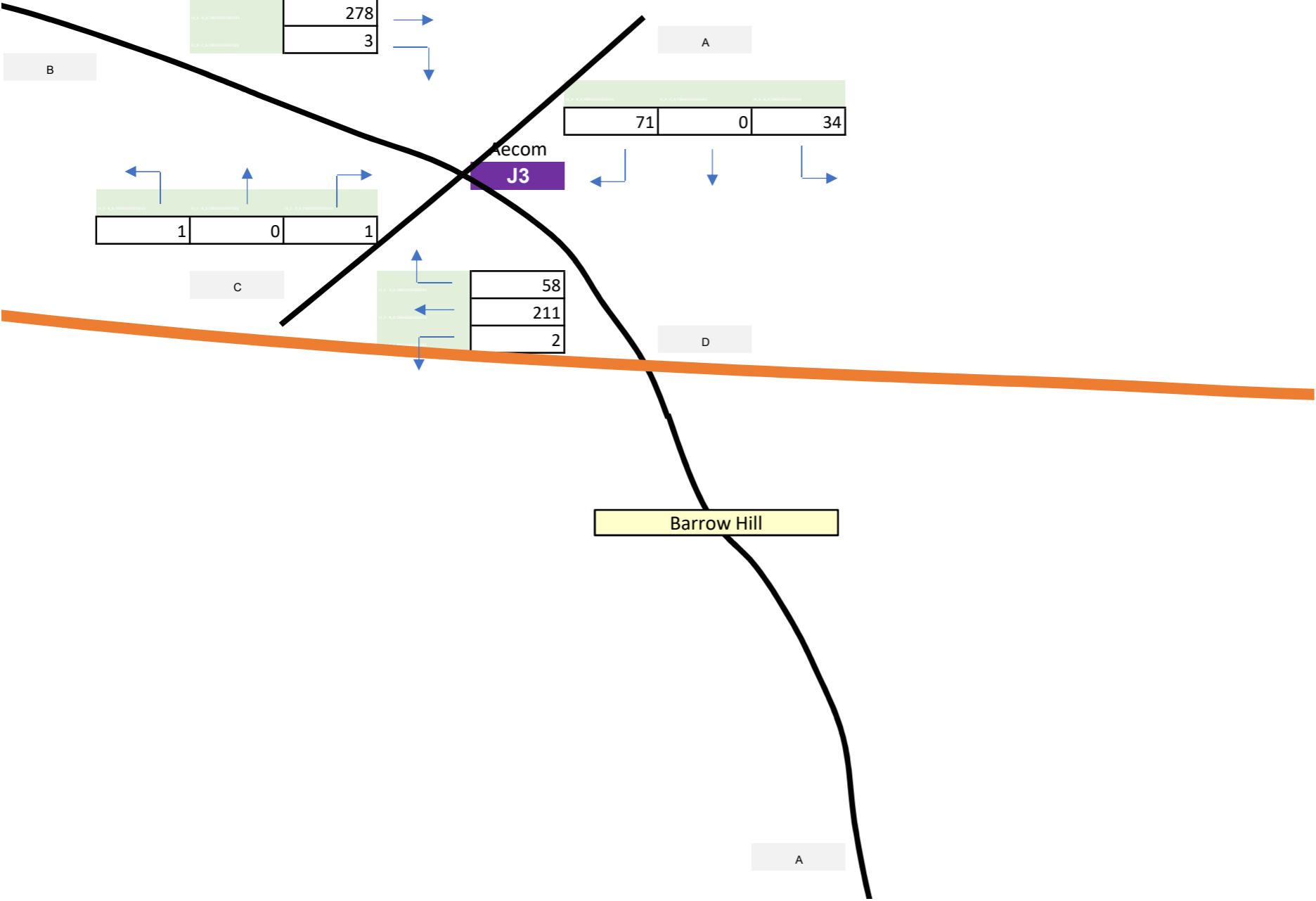

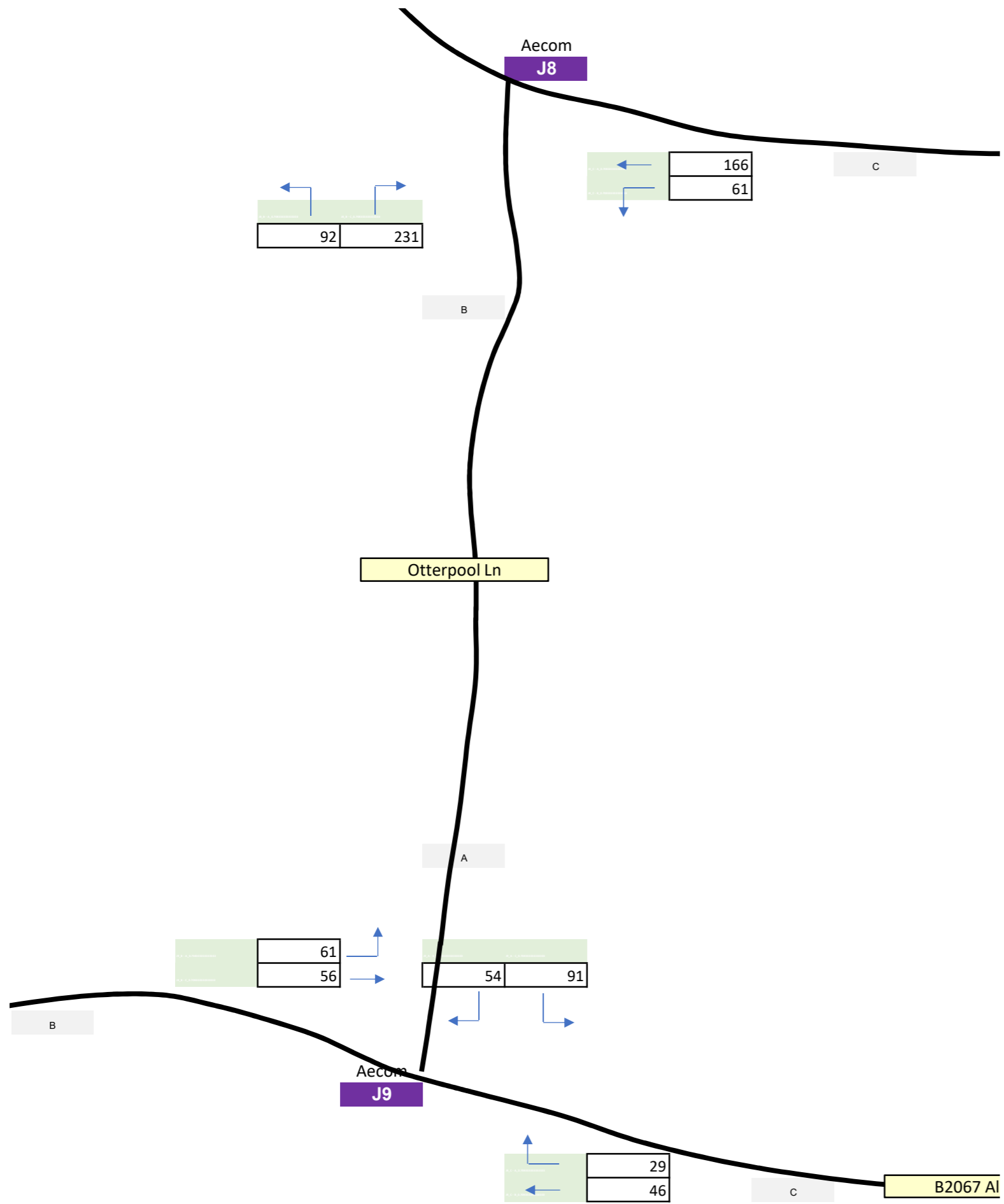

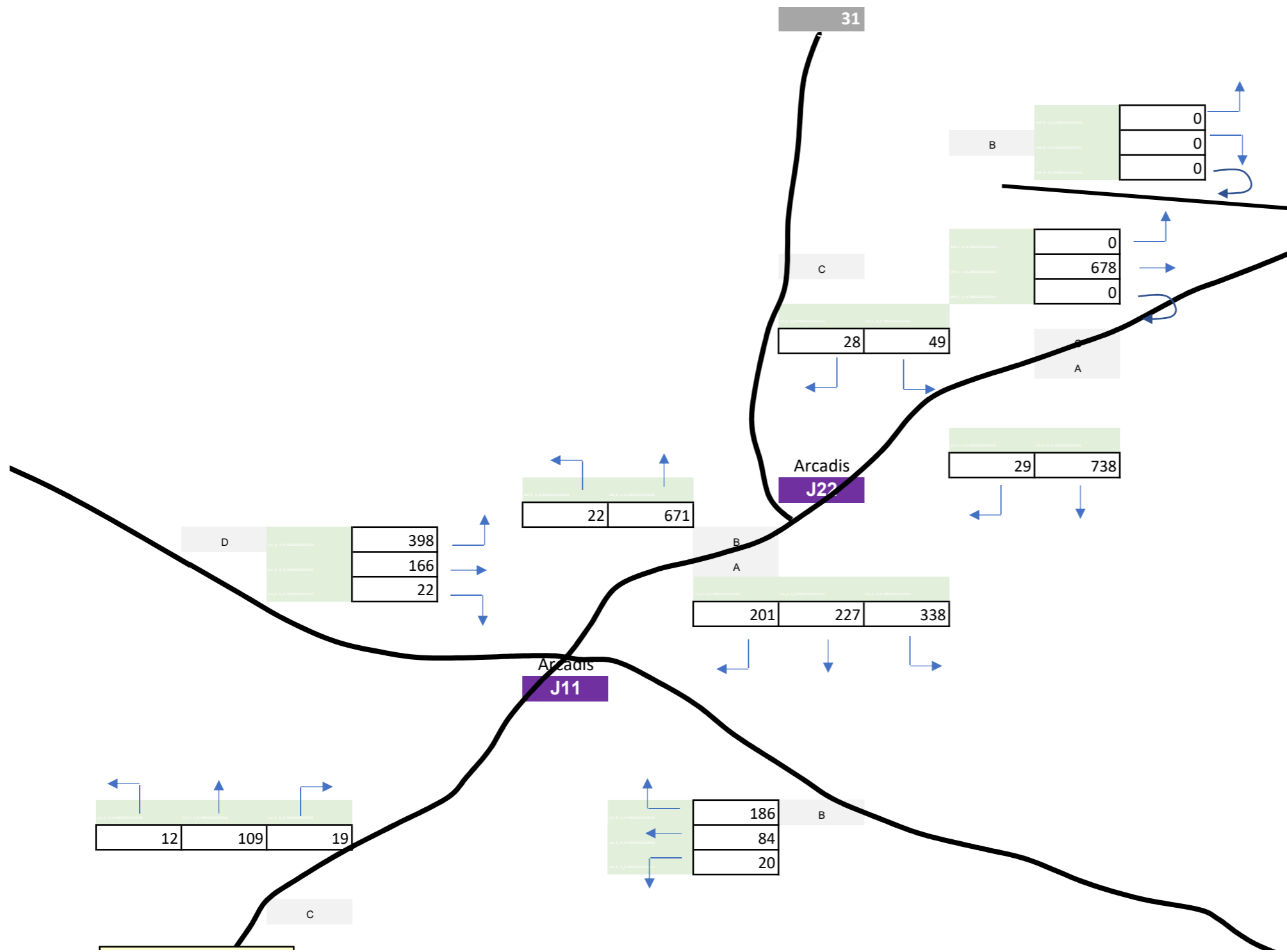

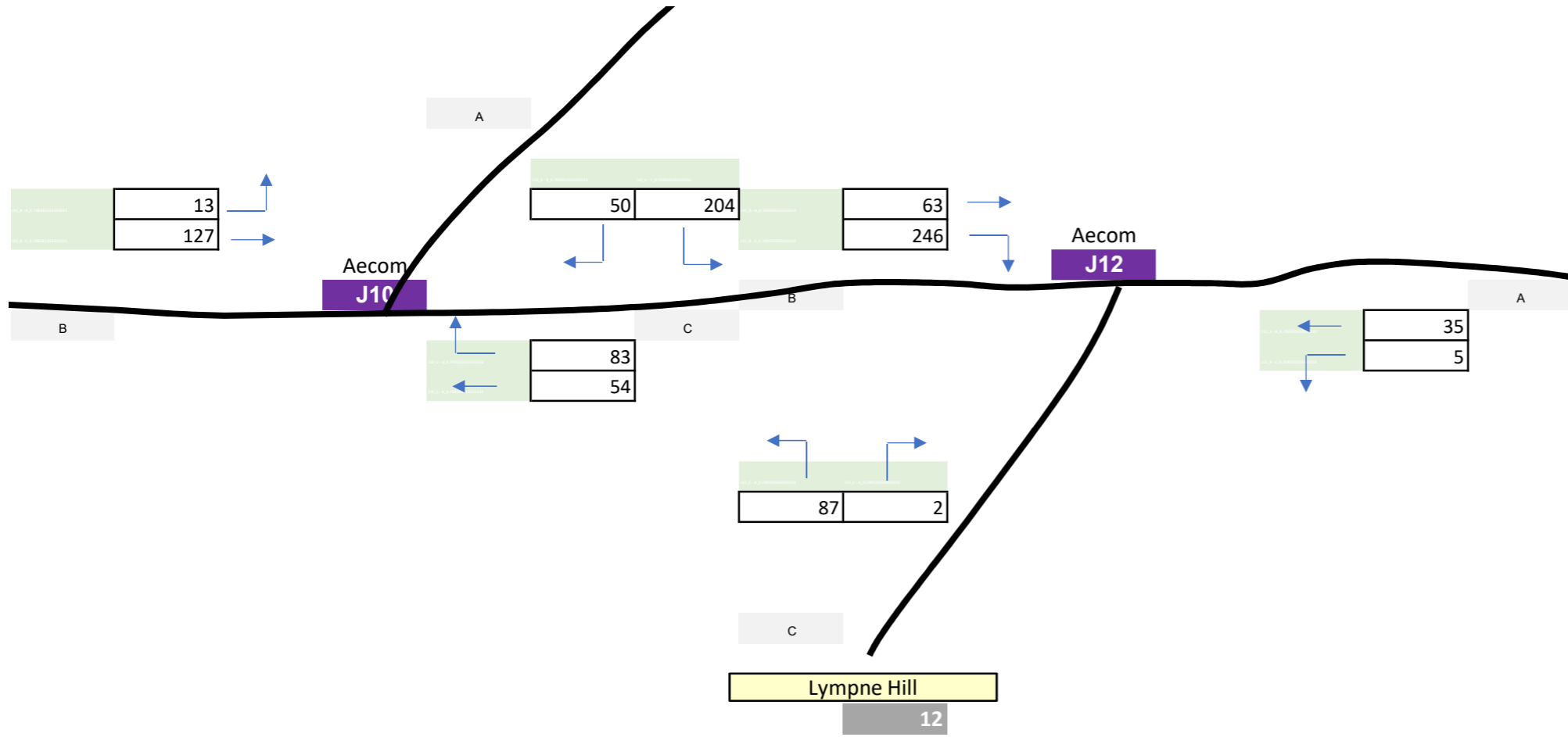

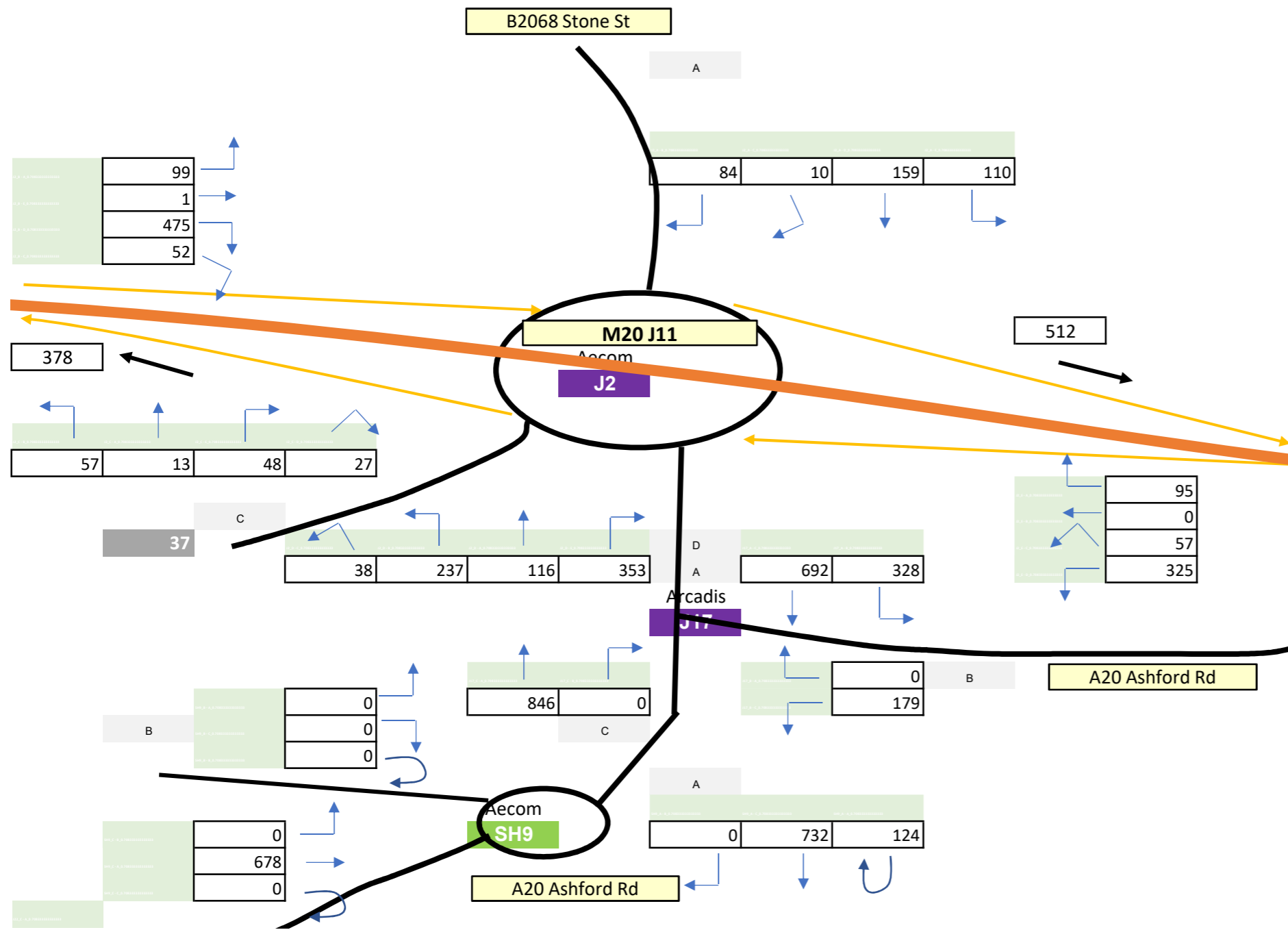

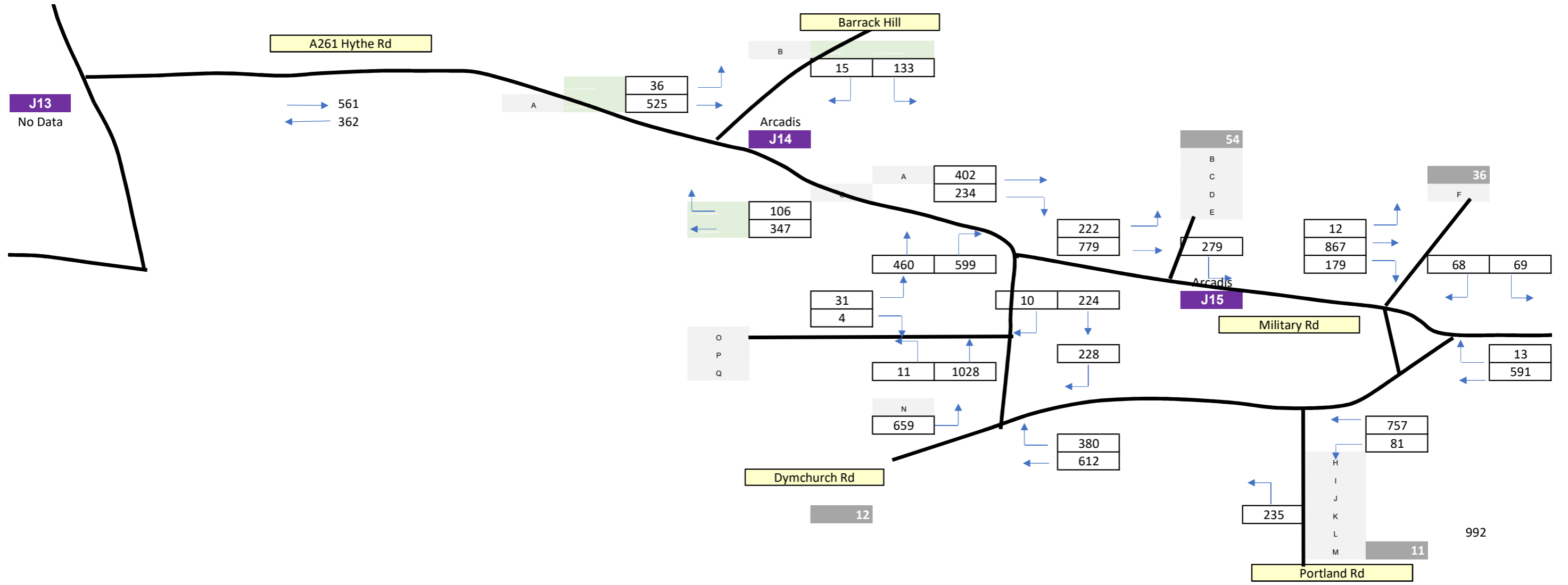

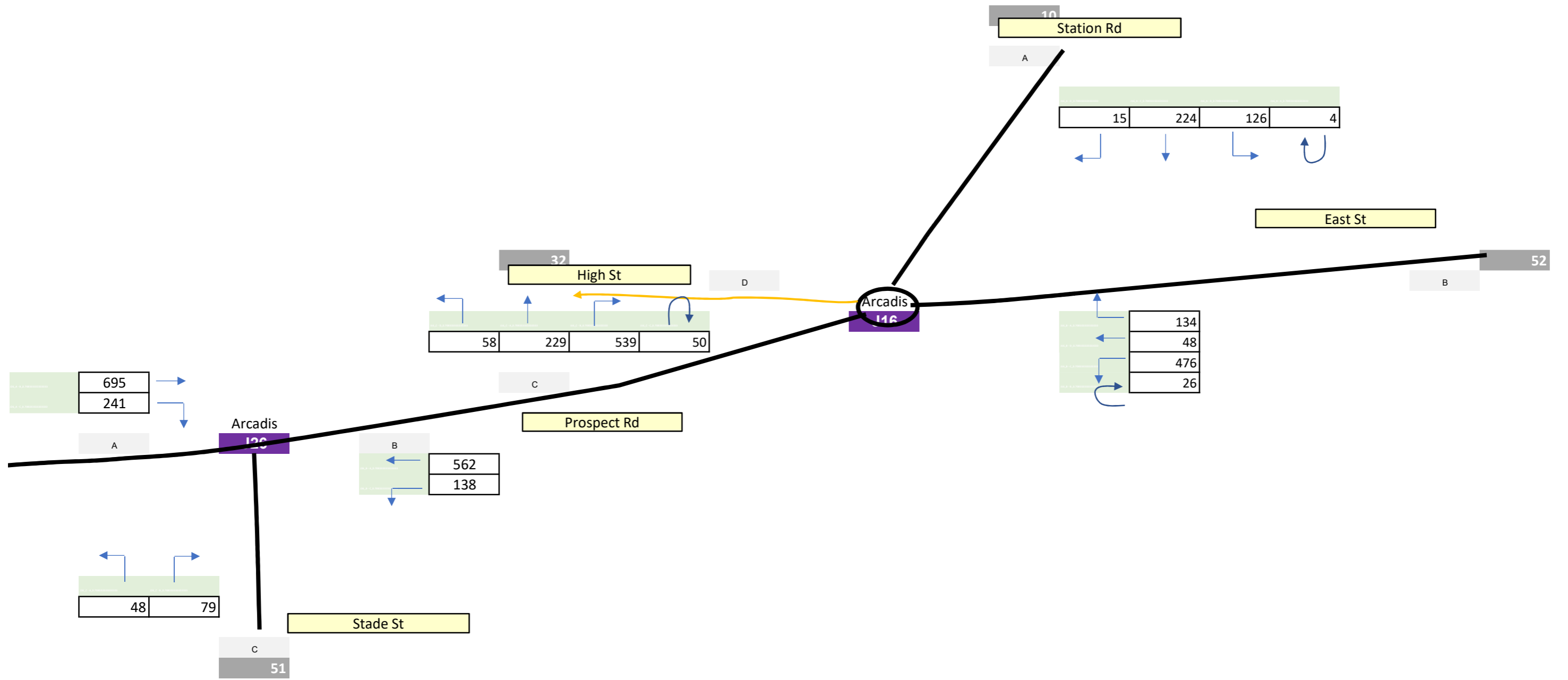

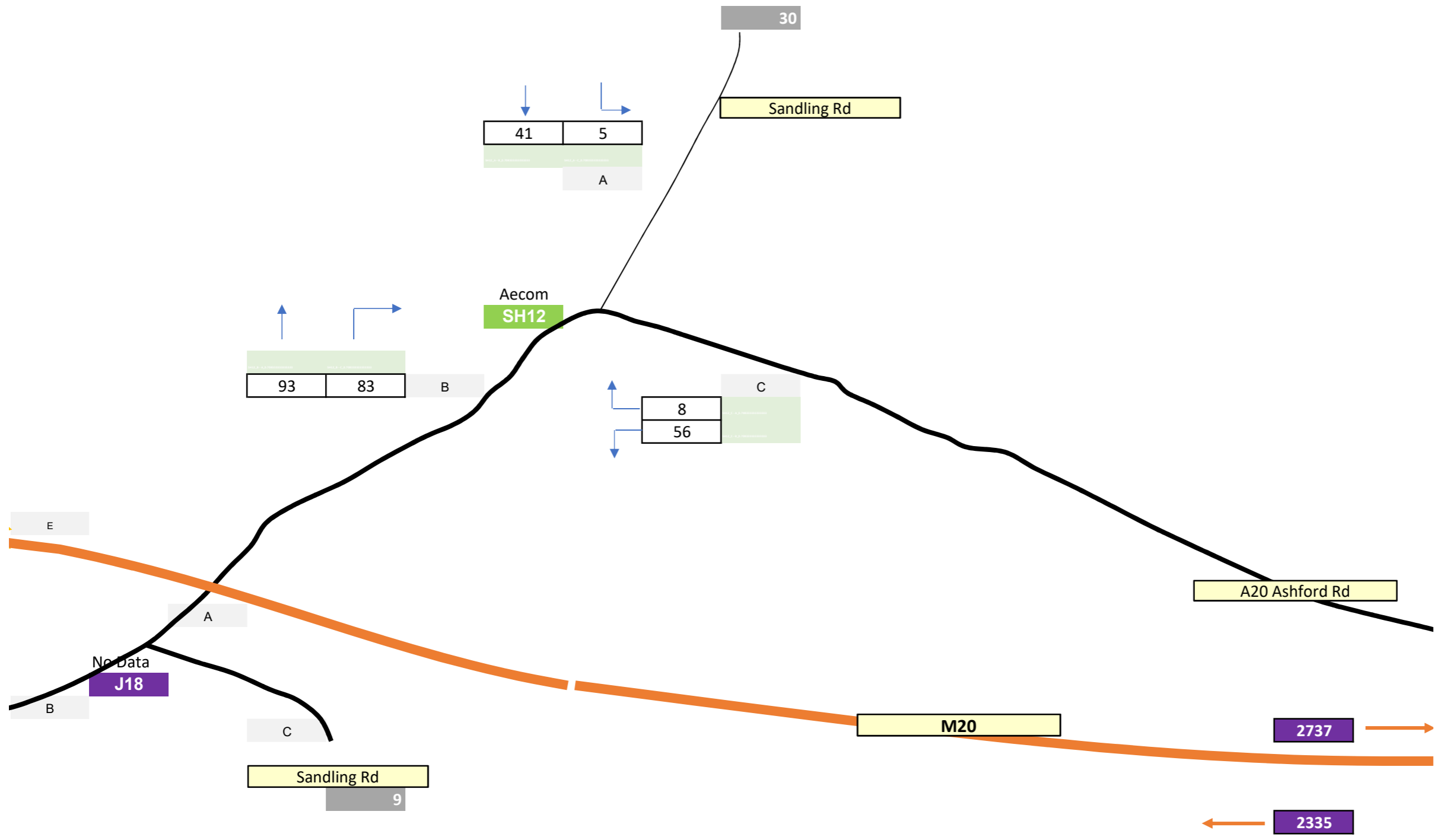

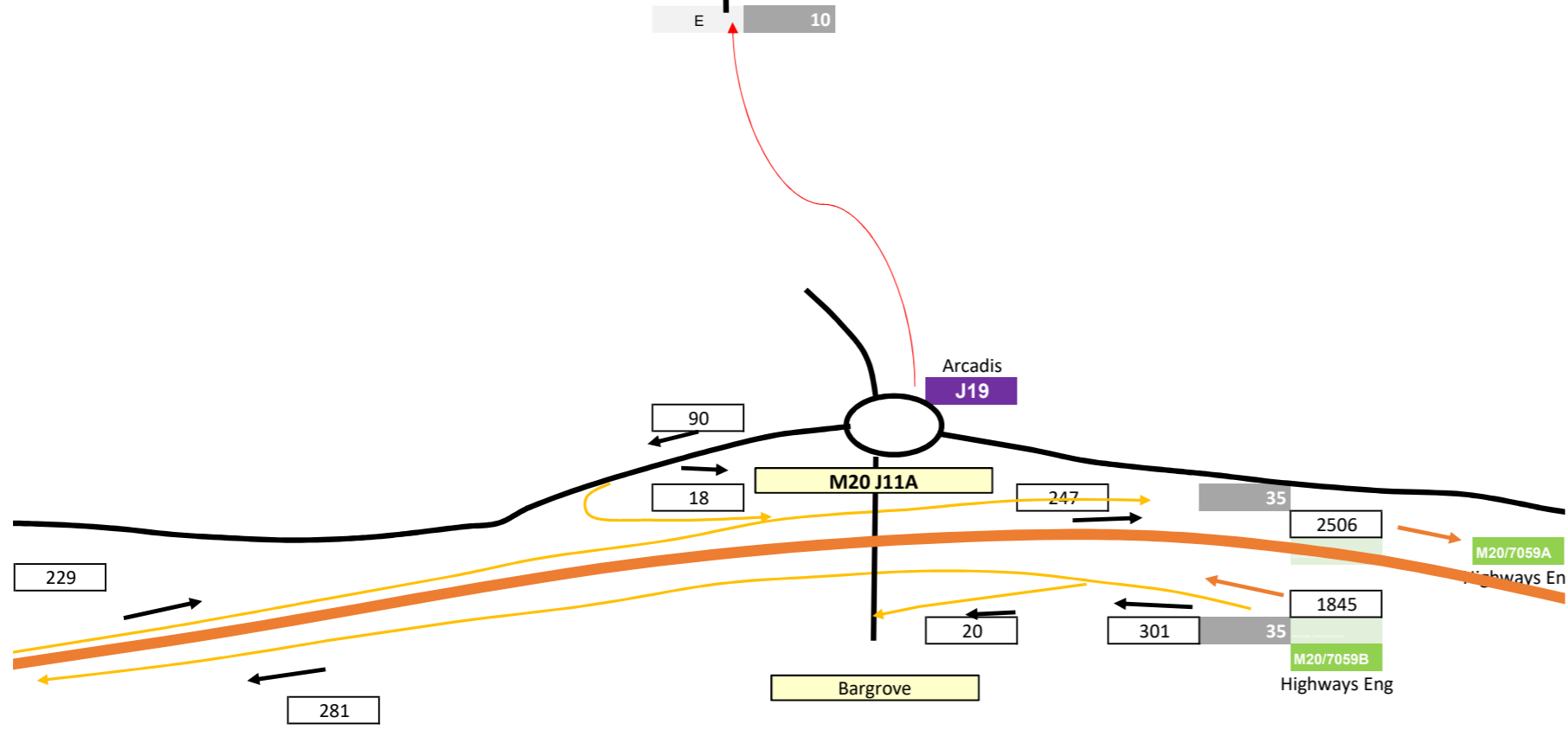
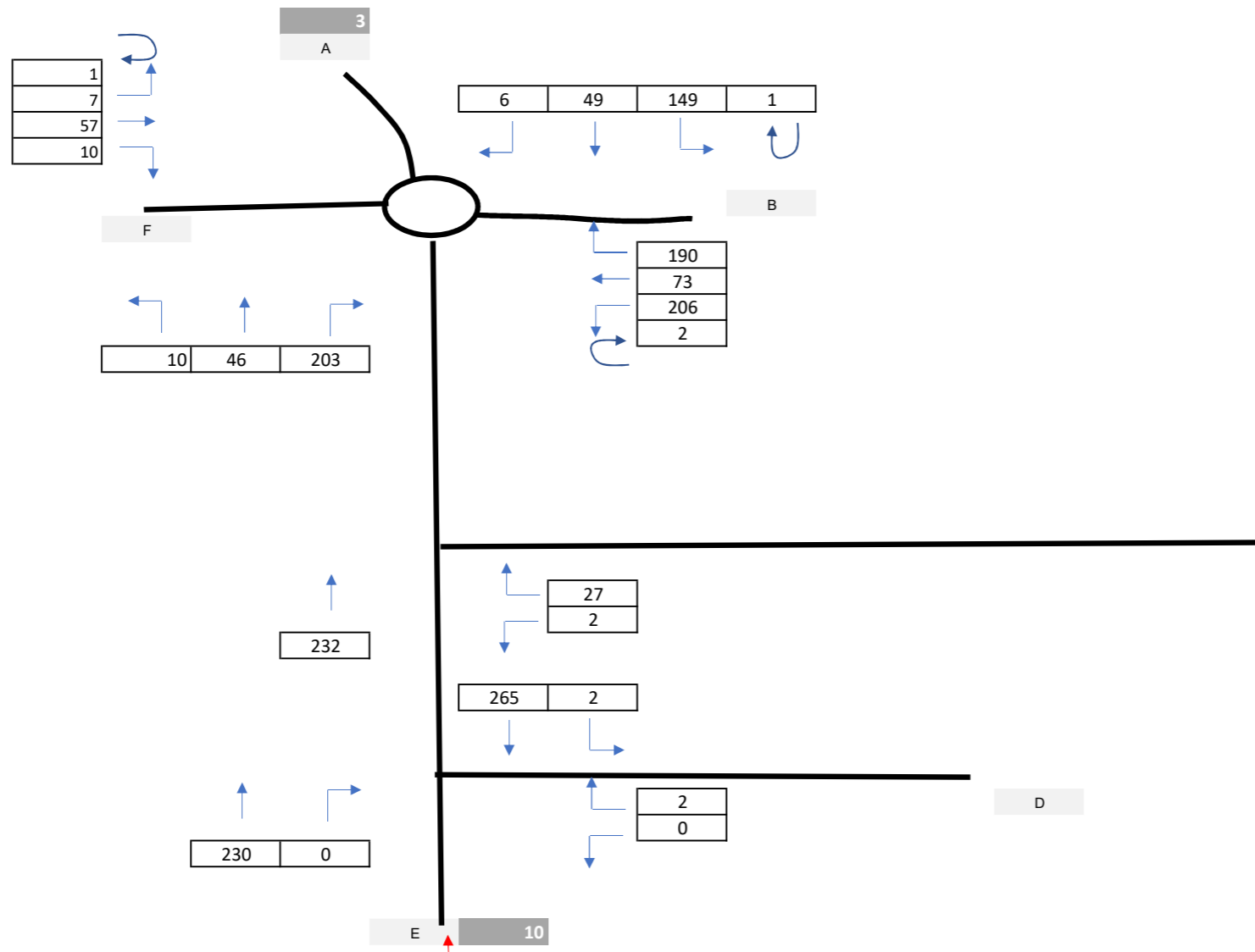

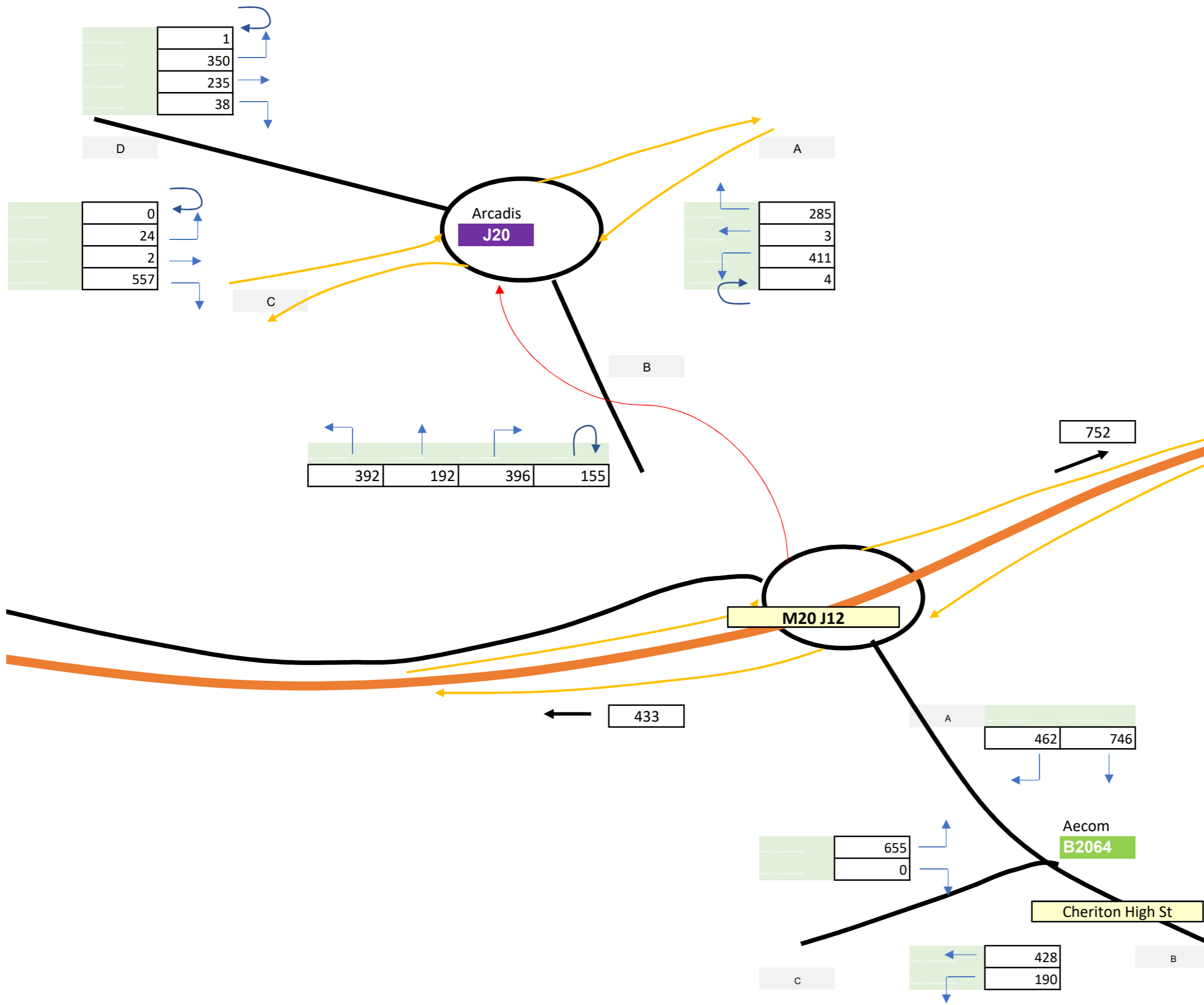

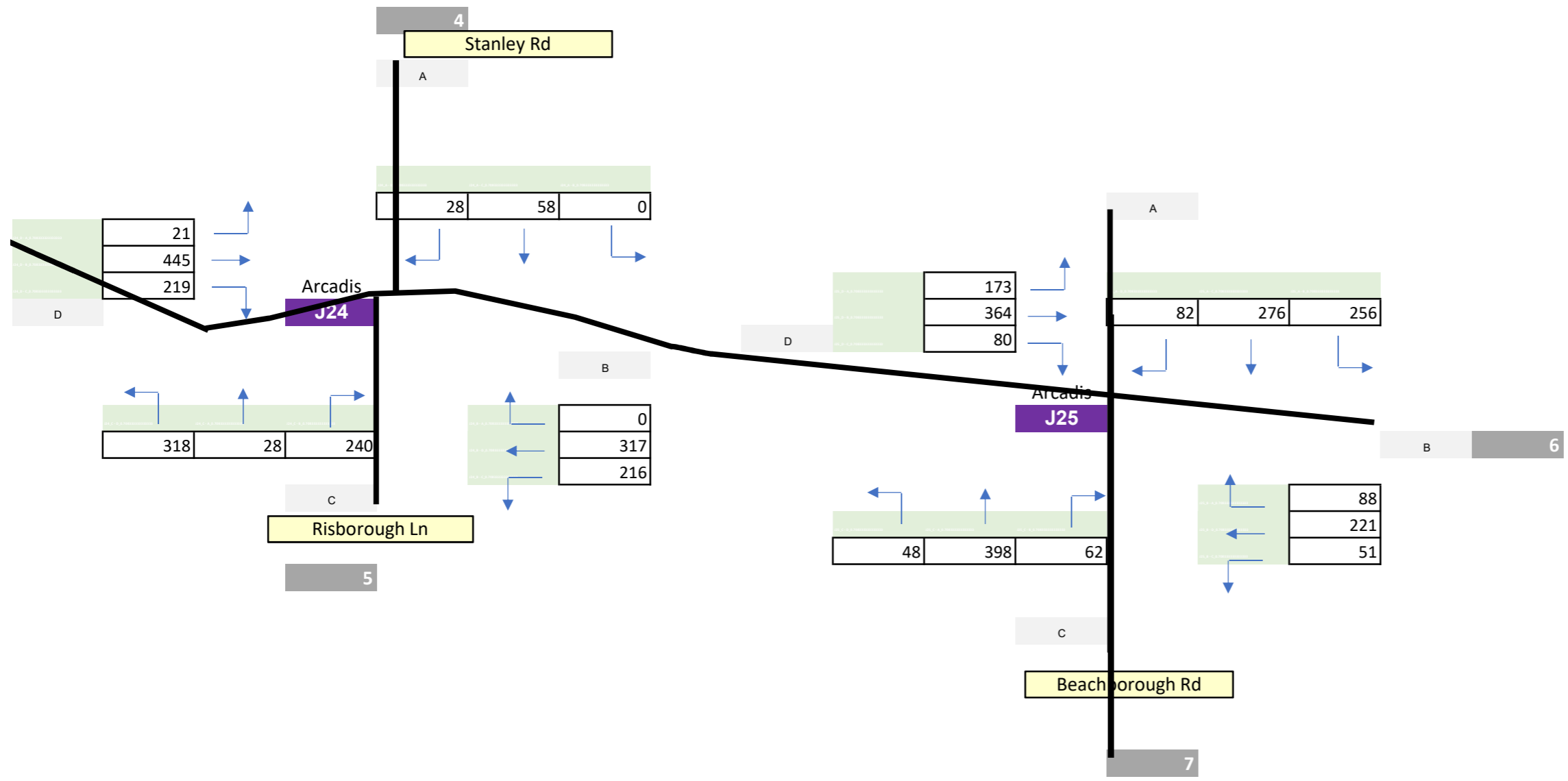

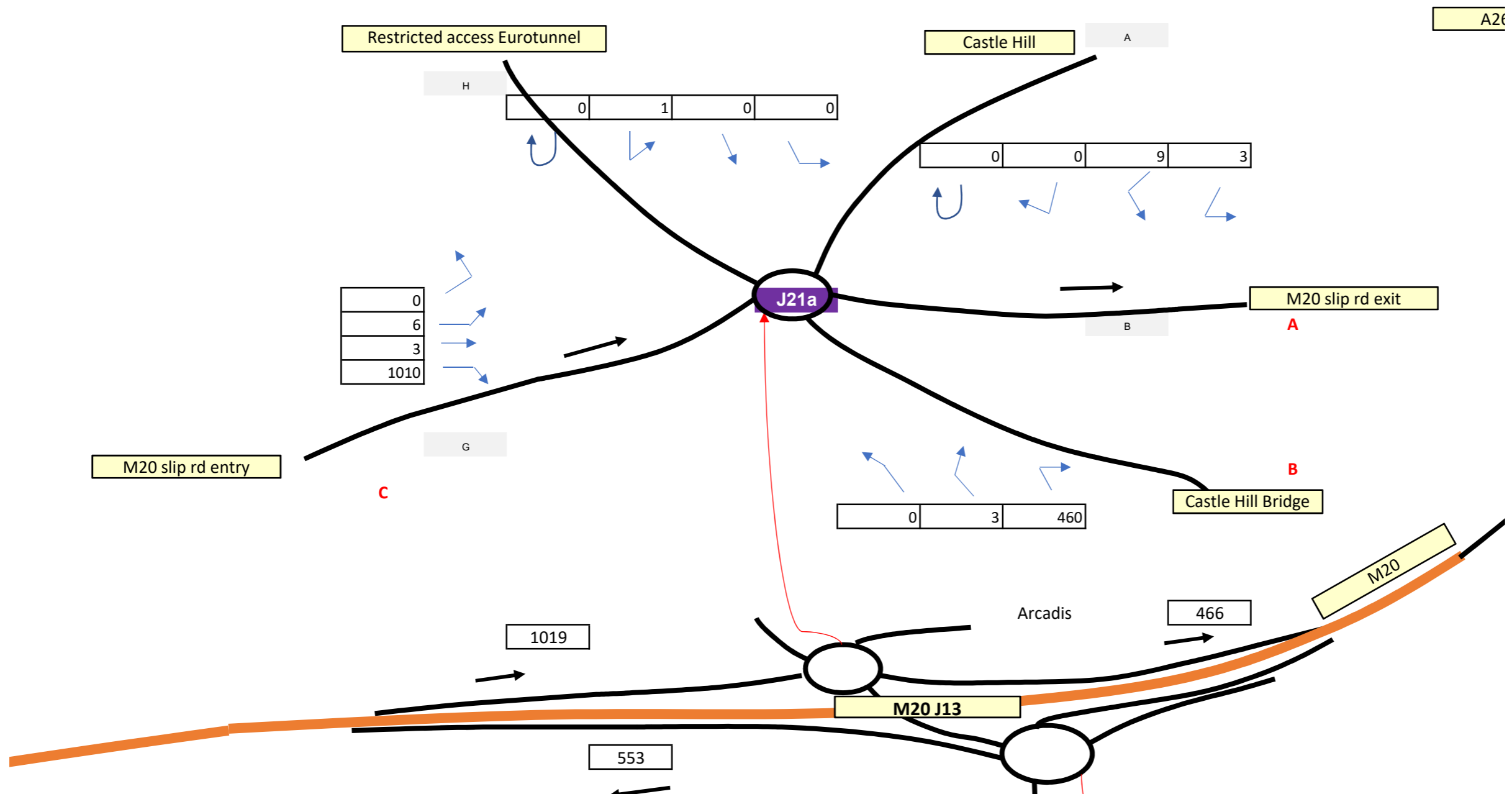

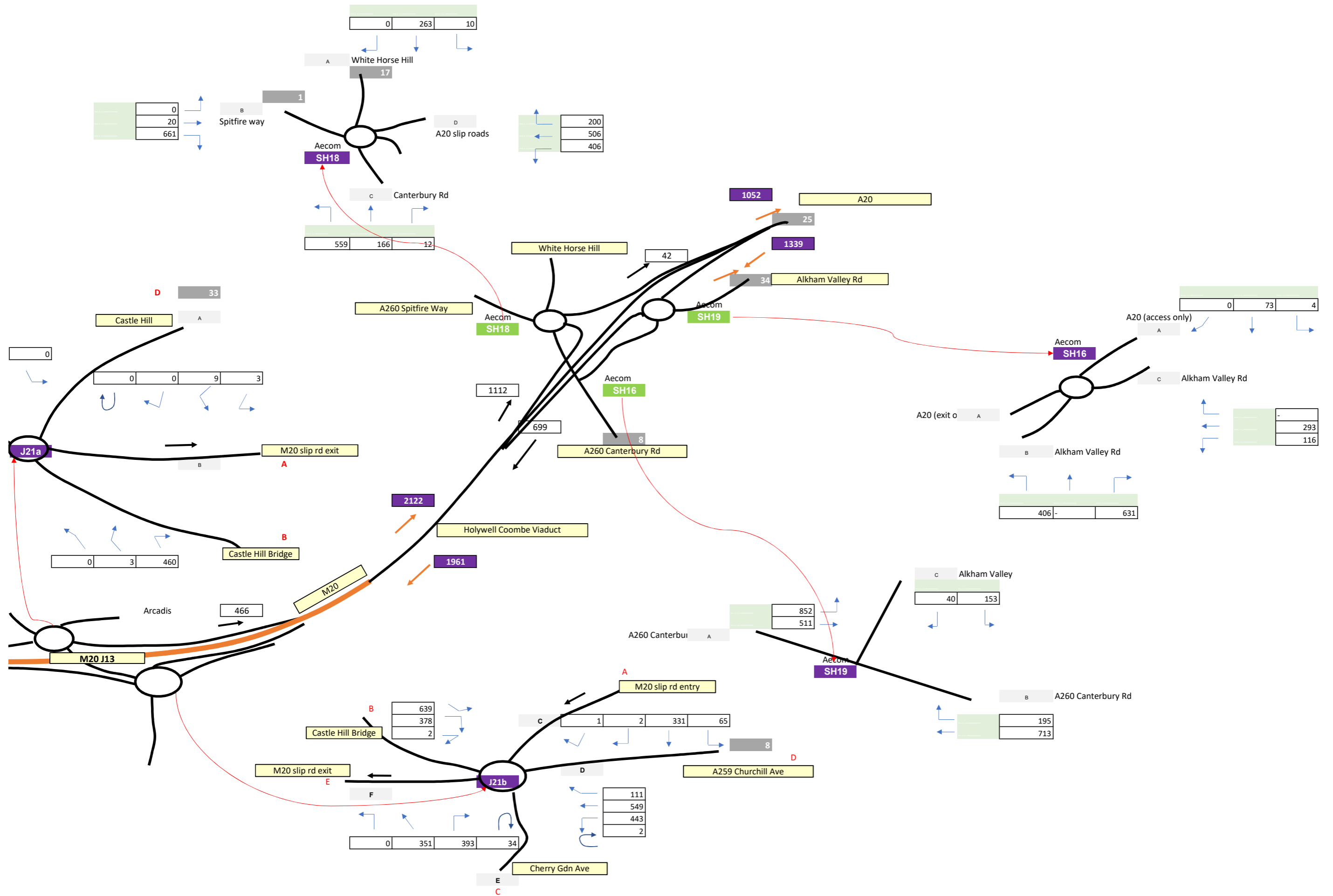

E.3 Canterbury - 2018 AM Peak

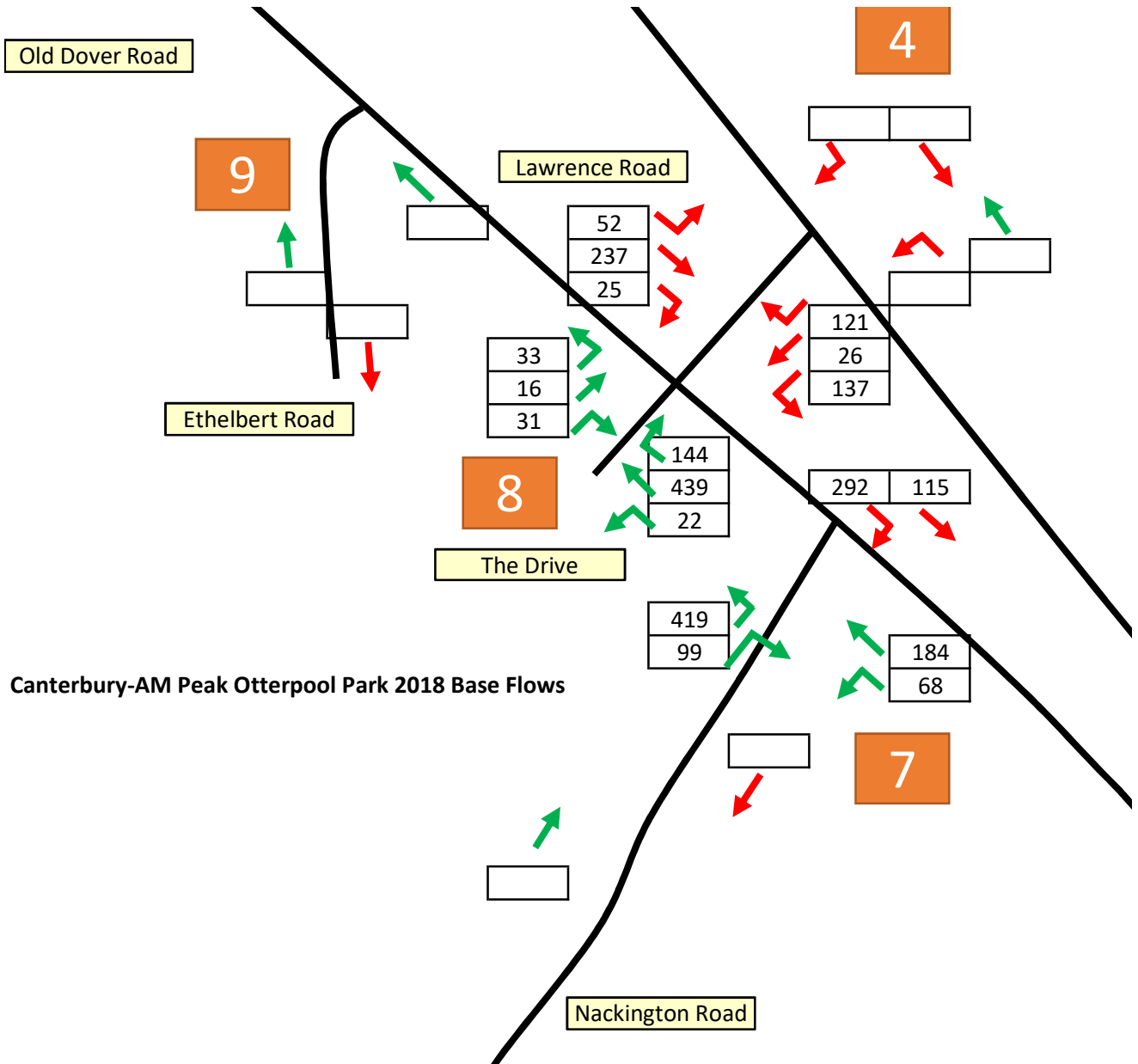

E.4 Canterbury - 2018 PM Peak

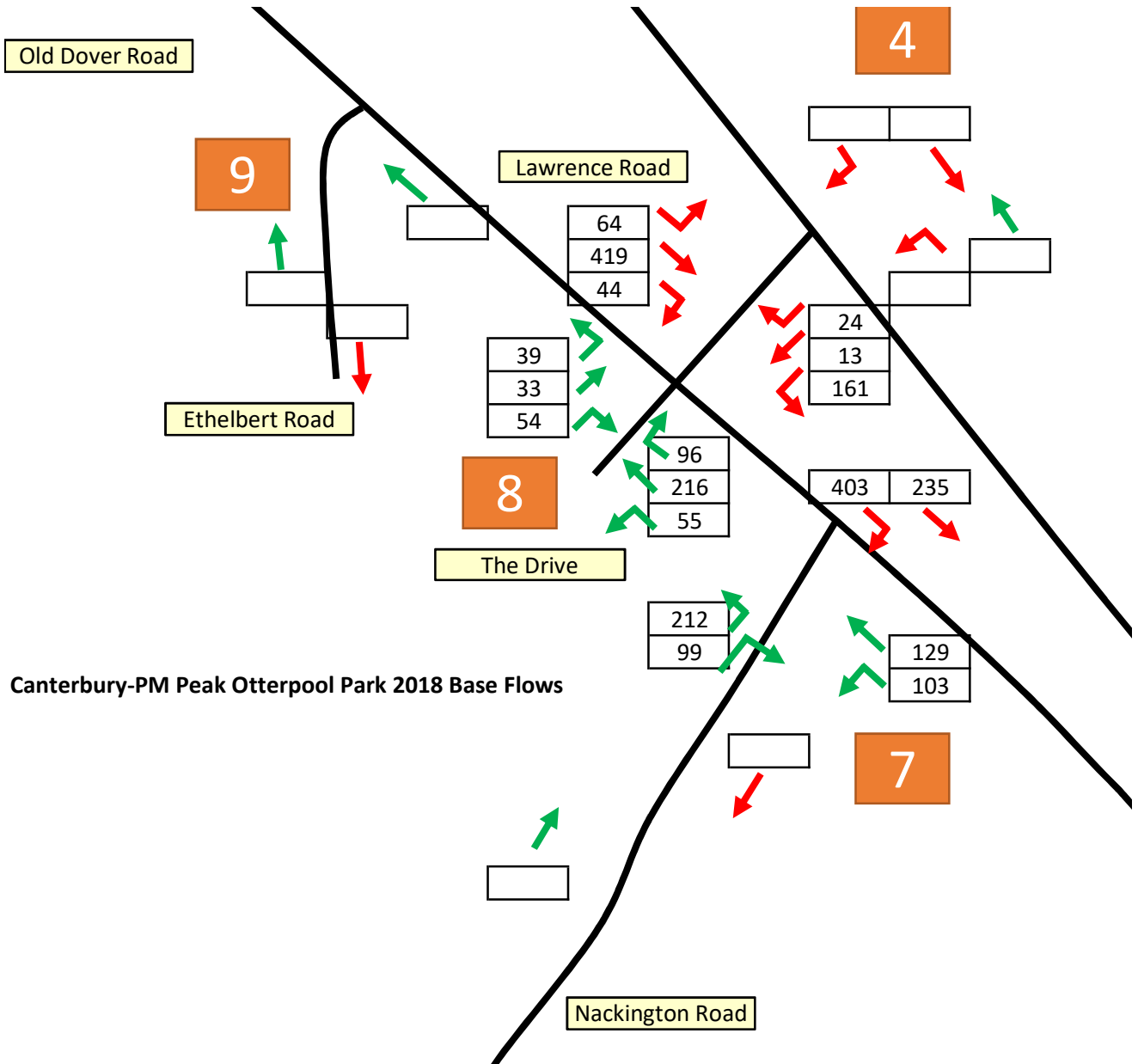

Canterbury-PM Peak Otterpool Park 2018 Base Flows

APPENDIX F - Baseline Modelling Outputs

F.1 J1_M20 Junction 10

Full Input Data And Results
Full Input Data And Results

User and Project Details

Project:	Otterpool Park
Title:	J1 M20 Junction 10
Location:	
Additional detail:	
File name:	J1 M20 Junction 10 v3 2018.lsg3x
Author:	Diego Moreno-Sosa
Company:	ARCADIS UK
Address:	

Network Layout Diagram

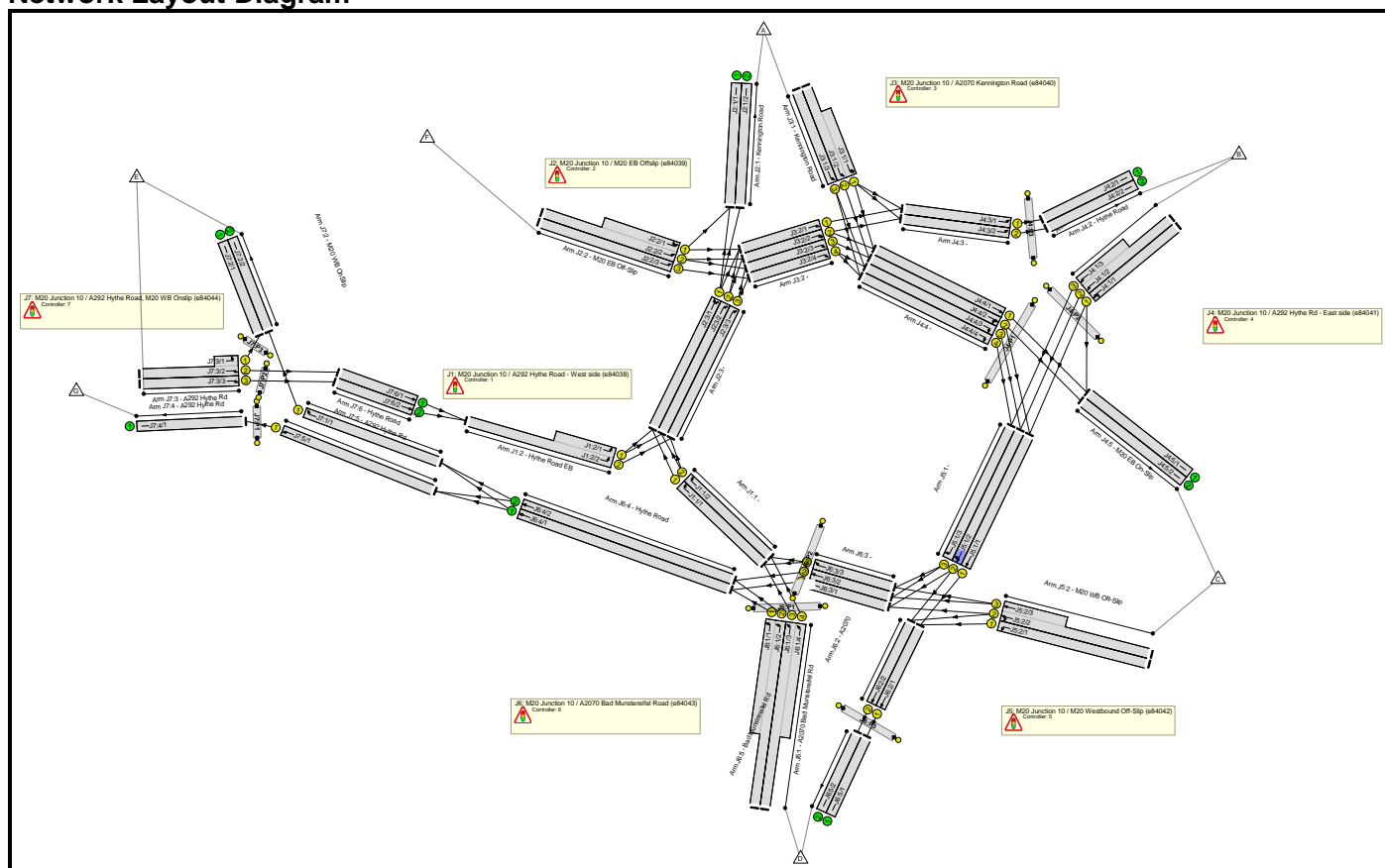

C1 - e84038
Phase Input Data

Phase Name	Phase Type	Assoc. Phase	Street Min	Cont Min
A	Traffic		7	7
B	Traffic		7	7
C	Dummy		3	3

Full Input Data And Results

Phase Intergreens Matrix

	Starting Phase			
		A	B	C
Terminating Phase	A		6	3
	B	6		3
	C	2	2	

Phases in Stage

Stage No.	Phases in Stage
1	A
2	B

Stage Diagram

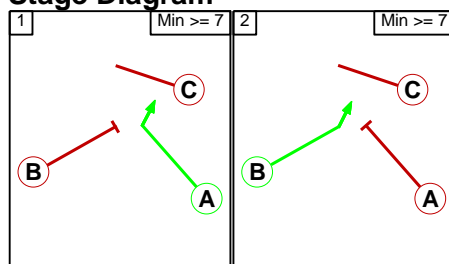

Phase Delays

Term. Stage	Start Stage	Phase	Type	Value	Cont value
There are no Phase Delays defined					

C2 - e84039

Phase Input Data

Phase Name	Phase Type	Assoc. Phase	Street Min	Cont Min
A	Traffic		7	7
B	Traffic		7	7
C	Dummy		3	3

Phase Intergreens Matrix

	Starting Phase			
		A	B	C
Terminating Phase	A		6	3
	B	7		3
	C	2	2	

Phases in Stage

Stage No.	Phases in Stage
1	A
2	B

Full Input Data And Results

Stage Diagram

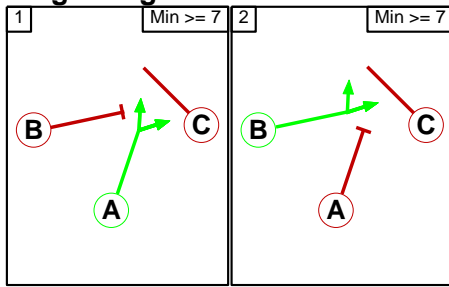

Phase Delays

Term. Stage	Start Stage	Phase	Type	Value	Cont value
There are no Phase Delays defined					

C3 - e84040

Phase Input Data

Phase Name	Phase Type	Assoc. Phase	Street Min	Cont Min
A	Traffic		7	7
B	Traffic		7	7
C	Dummy		3	3

Phase Intergreens Matrix

		Starting Phase		
		A	B	C
Terminating Phase	A	6	3	
	B	7		3
	C	2	2	

Phases in Stage

Stage No.	Phases in Stage
1	A
2	B

Stage Diagram

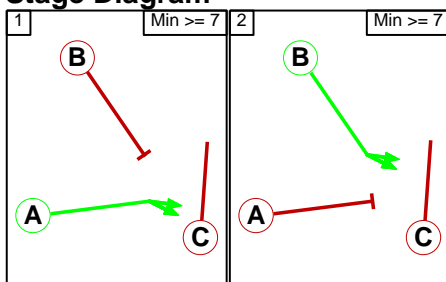

Phase Delays

Term. Stage	Start Stage	Phase	Type	Value	Cont value
There are no Phase Delays defined					

Full Input Data And Results

C4 - e84041

Phase Input Data

Phase Name	Phase Type	Stage Stream	Assoc. Phase	Street Min	Cont Min
A	Traffic	1		7	1
B	Traffic	1		7	0
C	Pedestrian	1		7	7
D	Pedestrian	1		7	7
E	Traffic	2		7	7
F	Pedestrian	2		6	6
G	Dummy	1		3	3
H	Dummy	2		3	3

Phase Intergreens Matrix

Terminating Phase	Starting Phase							
	A	B	C	D	E	F	G	H
A	-	6	6	-	-	-	3	-
B	7	-	-	7	-	-	3	-
C	14	-	-	-	-	-	3	-
D	-	12	-	-	-	-	3	-
E	-	-	-	-	-	5	-	3
F	-	-	-	-	9	-	-	3
G	2	2	-	-	-	-	-	-
H	-	-	-	-	2	2	-	-

Phases in Stage

Stream	Stage No.	Phases in Stage
1	1	A D
1	2	B C
2	1	E
2	2	F

Stage Diagram

Stage Stream: 1

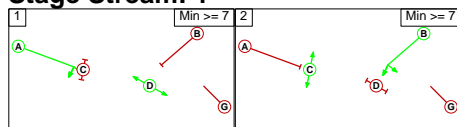

Stage Stream: 2

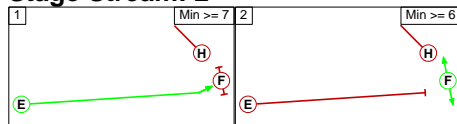

Full Input Data And Results

Phase Delays

Stage Stream: 1

Term. Stage	Start Stage	Phase	Type	Value	Cont value
1	2	A	Losing	6	6
2	1	B	Losing	7	7

Stage Stream: 2

Term. Stage	Start Stage	Phase	Type	Value	Cont value
There are no Phase Delays defined					

C5 - e84042

Phase Input Data

Phase Name	Phase Type	Assoc. Phase	Street Min	Cont Min
A	Traffic		7	7
B	Traffic		7	7
C	Dummy		3	3

Phase Intergreens Matrix

		Starting Phase		
Terminating Phase		A	B	C
	A		6	3
	B	7		3
	C	2	2	

Phases in Stage

Stage No.	Phases in Stage
1	A
2	B

Stage Diagram

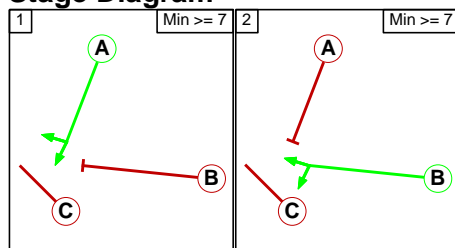

Phase Delays

Term. Stage	Start Stage	Phase	Type	Value	Cont value
There are no Phase Delays defined					

Full Input Data And Results

C6 - e84043

Phase Input Data

Phase Name	Phase Type	Stage Stream	Assoc. Phase	Street Min	Cont Min
A	Traffic	1		7	0
B	Traffic	1		7	0
C	Pedestrian	1		7	7
D	Pedestrian	1		7	7
E	Traffic	2		7	7
F	Pedestrian	2		6	6
G	Dummy	1		3	3
H	Dummy	2		3	3

Phase Intergreens Matrix

		Starting Phase							
		A	B	C	D	E	F	G	H
Terminating Phase	A		7	7	-	-	-	3	-
	B	7		-	7	-	-	3	-
	C	12	-		-	-	-	3	-
	D	-	14	-		-	-	3	-
	E	-	-	-	-		5	-	3
	F	-	-	-	-	10		-	3
	G	2	2	-	-	-	-		-
	H	-	-	-	-	2	2	-	

Phases in Stage

Stream	Stage No.	Phases in Stage
1	1	A D
1	2	B C
2	1	E
2	2	F

Stage Diagram

Stage Stream: 1

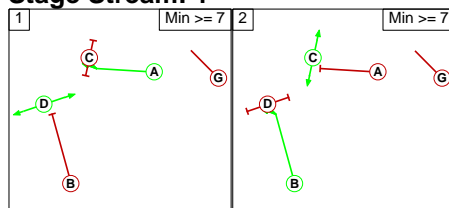

Stage Stream: 2

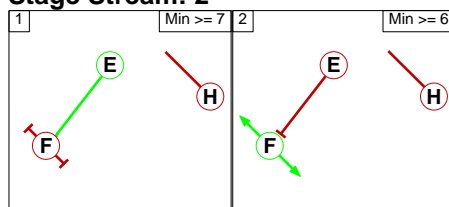

Full Input Data And Results

Phase Delays

Stage Stream: 1

Term. Stage	Start Stage	Phase	Type	Value	Cont value
1	2	A	Losing	7	7
2	1	B	Losing	7	7

Stage Stream: 2

Term. Stage	Start Stage	Phase	Type	Value	Cont value
There are no Phase Delays defined					

C7 - e84044

Phase Input Data

Phase Name	Phase Type	Assoc. Phase	Street Min	Cont Min
A	Traffic		7	7
B	Traffic		7	7
C	Traffic		7	7
D	Pedestrian		5	5
E	Pedestrian		5	5
F	Pedestrian		5	5
G	Dummy		3	3

Phase Intergreens Matrix

		Starting Phase						
		A	B	C	D	E	F	G
Terminating Phase	A	-	-	7	-	-	-	3
	B	-	-	5	-	5	5	3
	C	-	7	-	-	-	-	3
	D	7	-	-	-	-	-	3
	E	-	7	-	-	-	-	3
	F	-	7	-	-	-	-	3
	G	2	2	2	2	2	2	-

Phases in Stage

Stage No.	Phases in Stage
1	A B
2	A C E F
3	B D

Stage Diagram

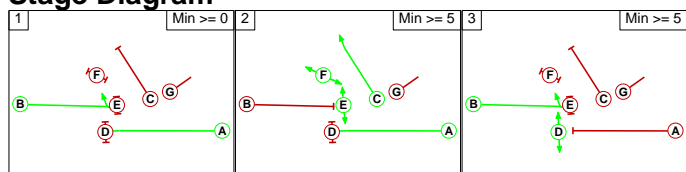

Full Input Data And Results

Phase Delays

Term. Stage	Start Stage	Phase	Type	Value	Cont value
There are no Phase Delays defined					

Traffic Flows, Desired

Scenario 1: 'Base AM' (FG1: 'AM Peak 2018', Plan 1: 'Network Control Plan 1')

Desired Flow :

	Destination								
	A	B	C	D	E	F	G	Tot.	
Origin	A	0	33	57	102	196	0	12	400
B	57	0	79	274	460	0	34	904	
C	190	30	0	568	0	0	240	1028	
D	265	236	429	0	475	0	44	1449	
E	57	101	143	38	360	0	0	699	
F	216	273	0	683	0	0	43	1215	
G	0	0	0	0	0	0	0	0	
Tot.	785	673	708	1665	1491	0	373	5695	

Scenario 2: 'Base PM' (FG2: 'PM Peak 2018', Plan 1: 'Network Control Plan 1')

Desired Flow :

	Destination								
	A	B	C	D	E	F	G	Tot.	
Origin	A	0	82	136	167	207	0	47	639
B	60	0	92	272	303	0	76	803	
C	73	22	0	538	0	0	121	754	
D	177	269	533	0	562	0	176	1717	
E	31	168	143	55	261	0	0	658	
F	119	326	0	883	0	0	154	1482	
G	0	0	0	0	0	0	0	0	
Tot.	460	867	904	1915	1333	0	574	6053	

Scenario 1: 'Base AM' (FG1: 'AM Peak 2018', Plan 1: 'Network Control Plan 1')

C1 - e84038

Stage Sequence Diagram

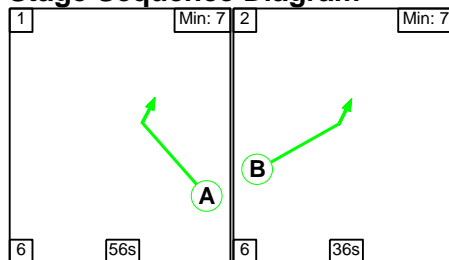

Stage Timings

Stage	1	2
Duration	56	36
Change Point	0	62

Signal Timings Diagram

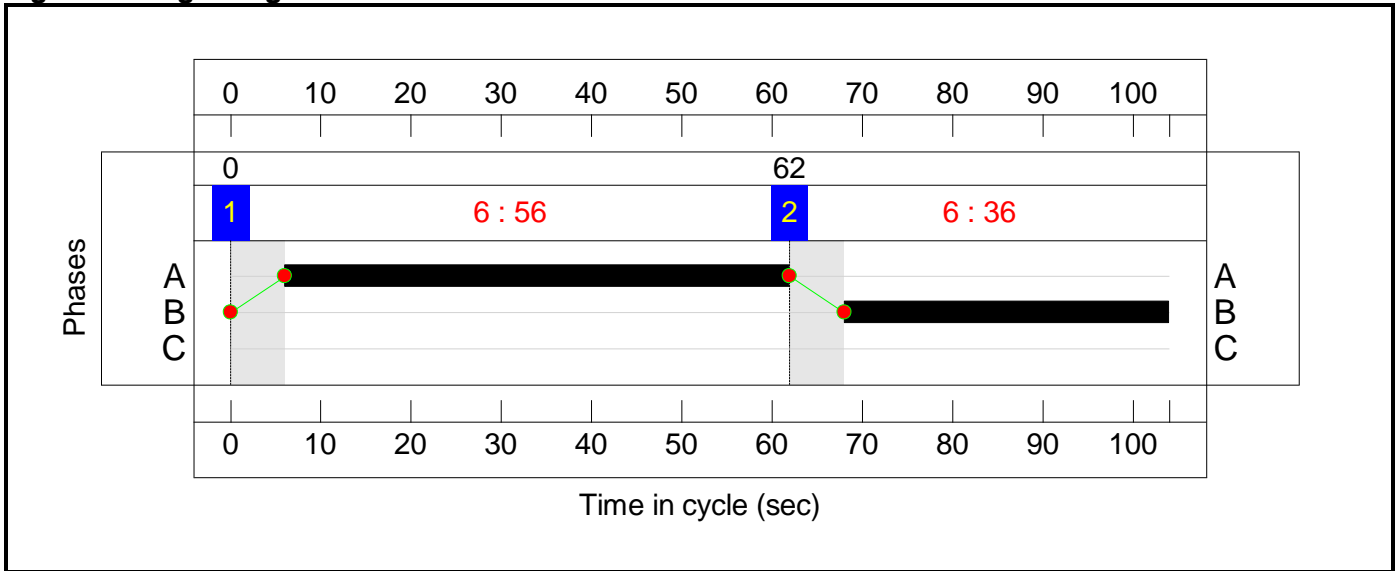

C2 - e84039

Stage Sequence Diagram

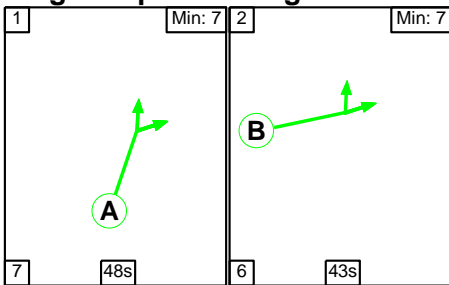

Stage Timings

Stage	1	2
Duration	48	43
Change Point	0	55

Signal Timings Diagram

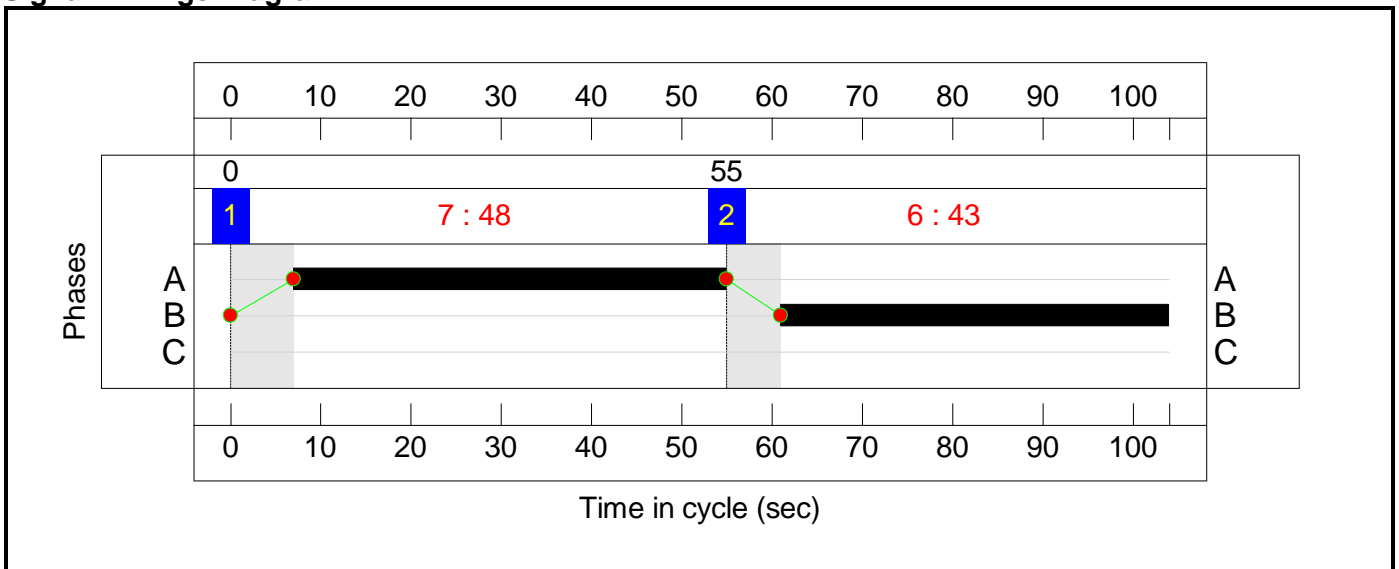

Full Input Data And Results

C3 - e84040

Stage Sequence Diagram

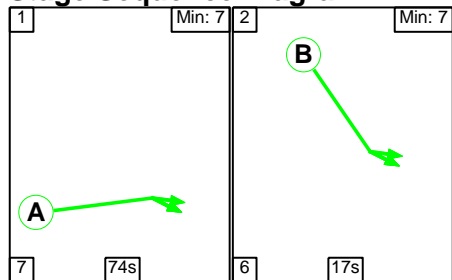

Stage Timings

Stage	1	2
Duration	74	17
Change Point	0	81

Signal Timings Diagram

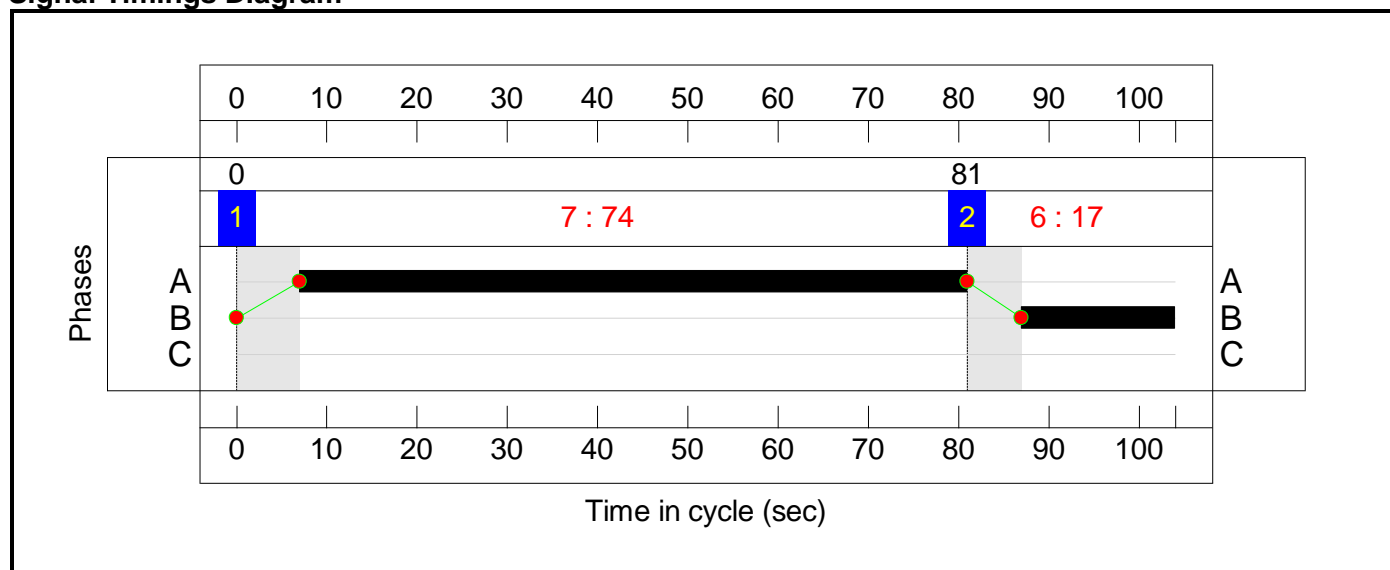

C4 - e84041

Stage Sequence Diagram

Stage Stream: 1

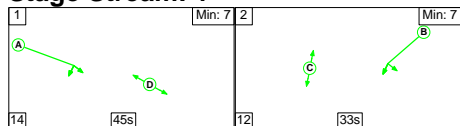

Stage Stream: 2

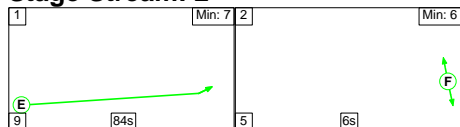

Stage Timings

Stage Stream: 1

Stage	1	2
Duration	45	33
Change Point	0	59

Full Input Data And Results

Stage Stream: 2

Stage	1	2
Duration	84	6
Change Point	3	96

Signal Timings Diagram

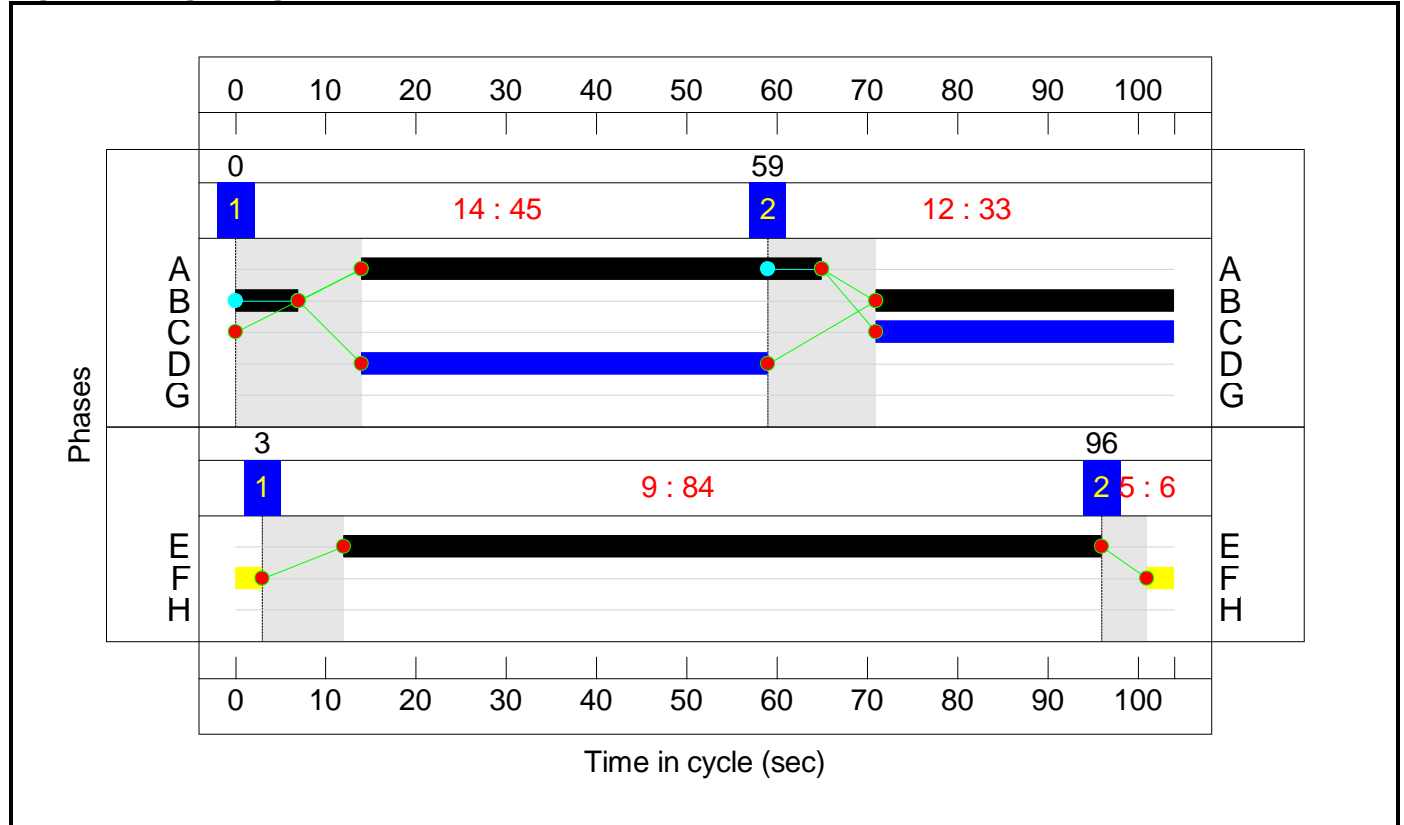

C5 - e84042

Stage Sequence Diagram

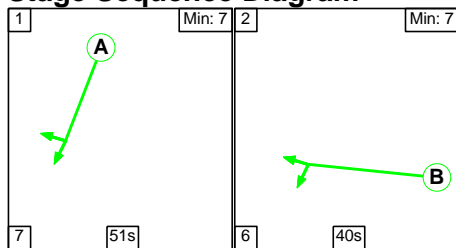

Stage Timings

Stage	1	2
Duration	51	40
Change Point	0	58

Signal Timings Diagram

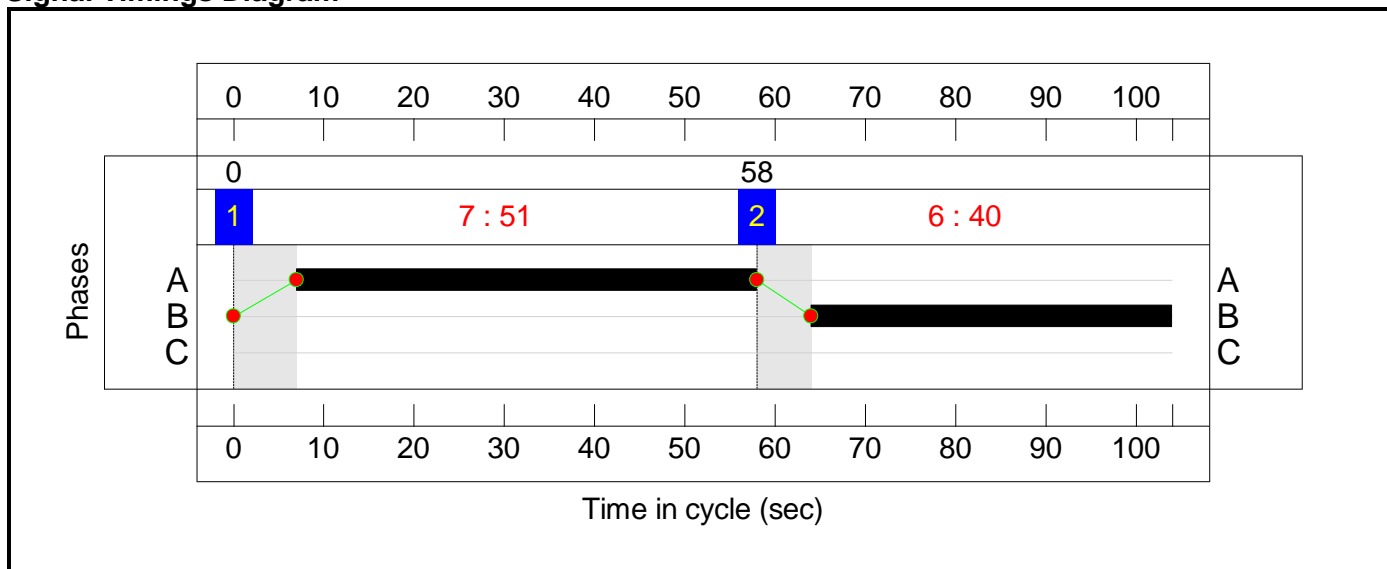

C6 - e84043

Stage Sequence Diagram

Stage Stream: 1

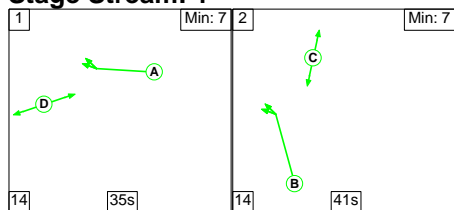

Stage Stream: 2

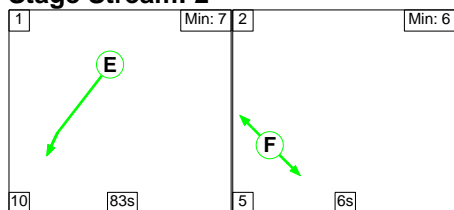

Stage Timings

Stage Stream: 1

Stage	1	2
Duration	35	41
Change Point	4	53

Stage Stream: 2

Stage	1	2
Duration	83	6
Change Point	0	93

Signal Timings Diagram

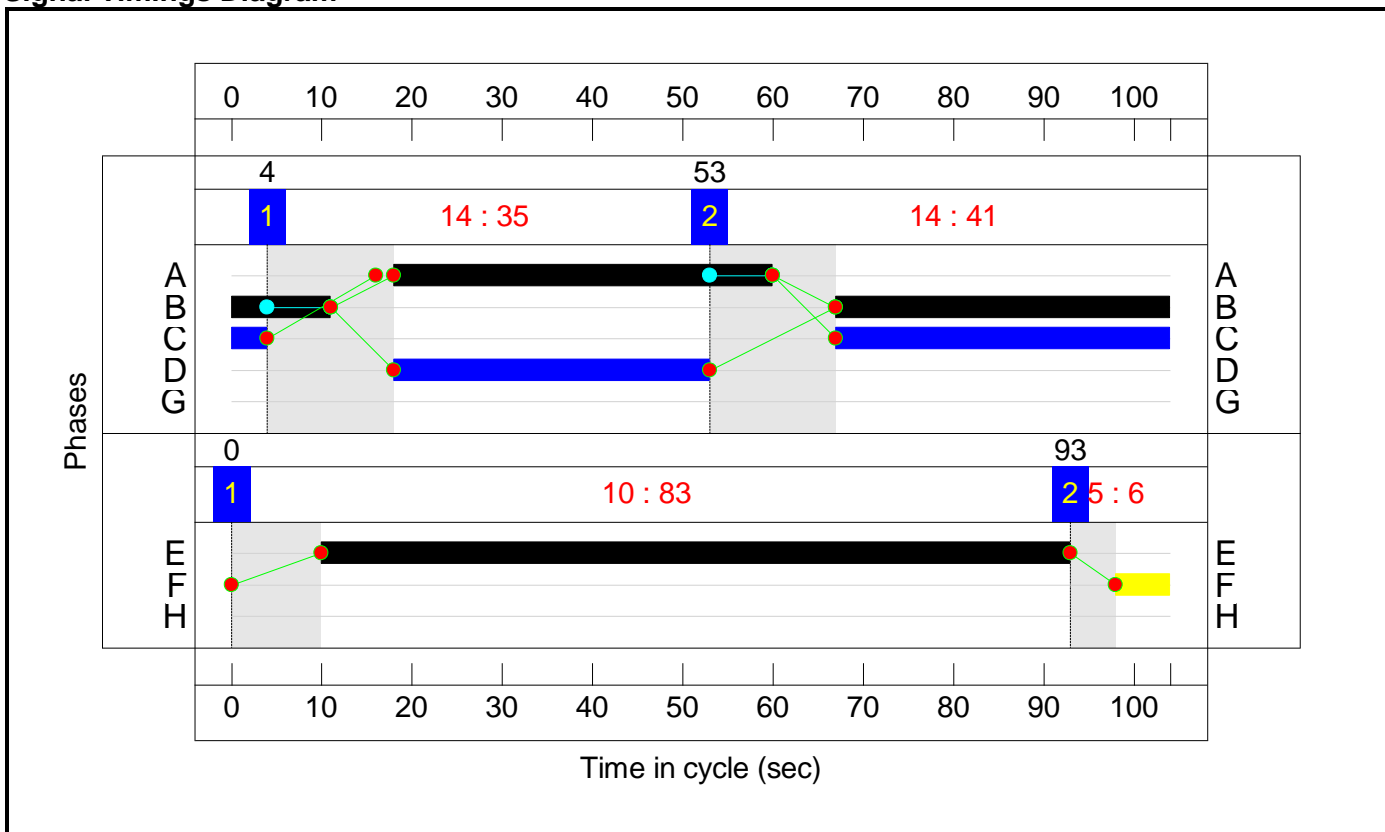

C7 - e84044

Stage Sequence Diagram

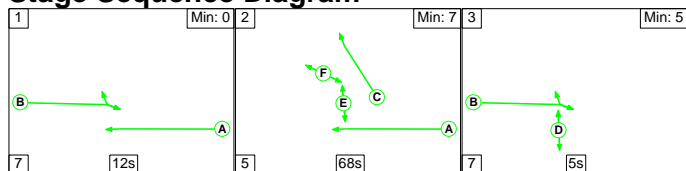

Stage Timings

Stage	1	2	3
Duration	12	68	5
Change Point	39	58	27

Signal Timings Diagram

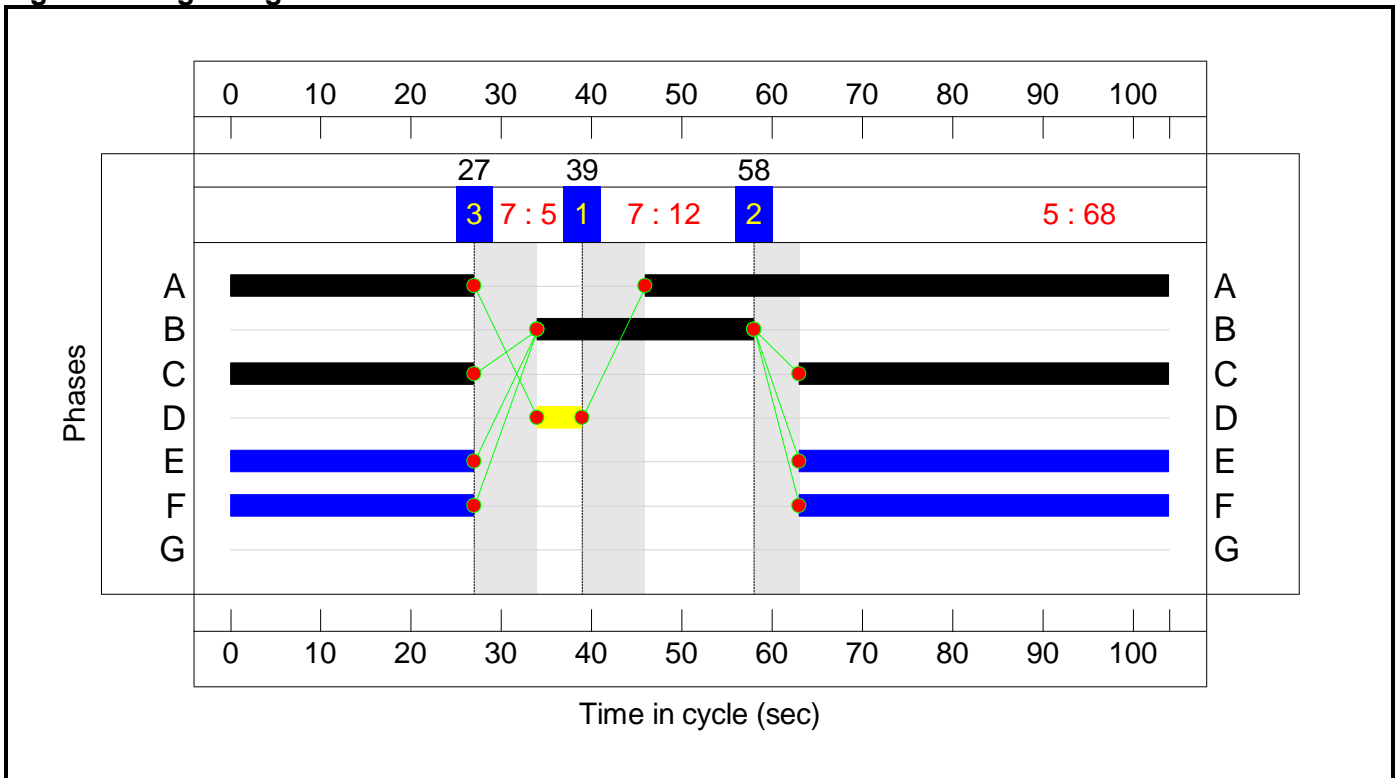

Full Input Data And Results Network Layout Diagram

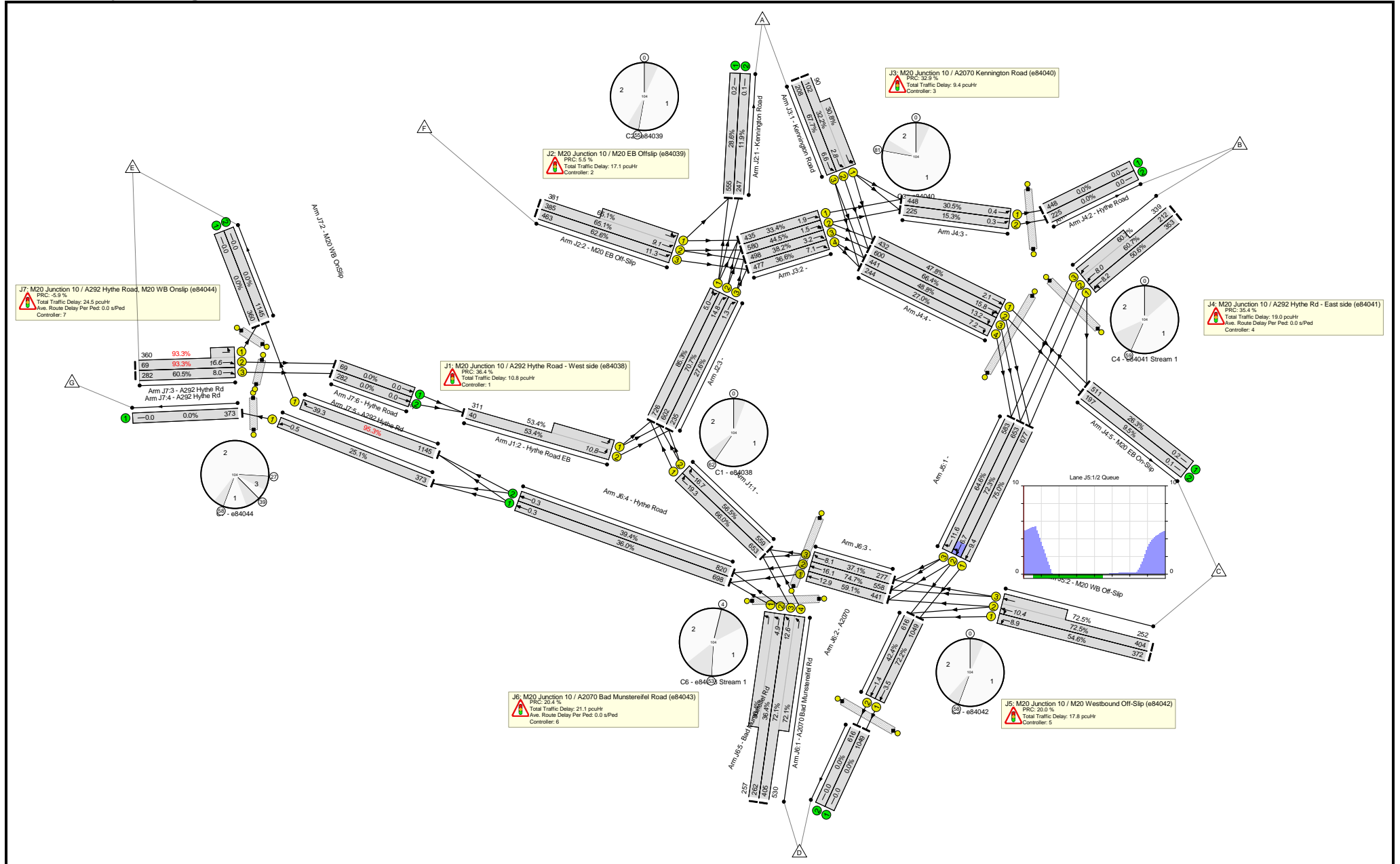

Full Input Data And Results

Network Results

Scenario 1: 'Base AM ' (FG1: 'AM Peak 2018', Plan 1: 'Network Control Plan 1')

Item	Lane Description	Lane Type	Total Green (s)	Arrow Green (s)	Demand Flow (pcu)	Sat Flow (pcu/Hr)	Capacity (pcu)	Deg Sat (%)	Arriving (pcu)
Network: J1 M20 Junction 10	-	-	-	-	-	-	-	95.3%	-
J1: M20 Junction 10 / A292 Hythe Road - West side (e84038)	-	-	-	-	-	-	-	66.0%	-
1/1	Right	U	56	-	653	1806	990	66.0%	653
1/2	Right	U	56	-	559	1806	990	56.5%	559
2/2+2/1	Hythe Road EB Left	U	36	-	351	1767:1737	75+583	53.4 : 53.4%	351
J2: M20 Junction 10 / M20 EB Offslip (e84039)	-	-	-	-	-	-	-	85.3%	-
1/1	Kennington Road	U	-	-	555	1940	1940	28.6%	555
1/2	Kennington Road	U	-	-	247	2080	2080	11.9%	247
2/2+2/1	M20 EB Off-Slip Ahead Left	U	43	-	766	1804:1796	591+585	65.1 : 65.1%	766
2/3	M20 EB Off-Slip Ahead	U	43	-	463	1747	739	62.6%	463
3/1	Right Ahead	U	48	-	726	1806	851	85.3%	726
3/2	Right	U	48	-	602	1806	851	70.7%	602
3/3	Right	U	48	-	235	1806	851	27.6%	235
J3: M20 Junction 10 / A2070 Kennington Road (e84040)	-	-	-	-	-	-	-	67.7%	-
1/2+1/1	Kennington Road Left Ahead	U	17	-	192	1828:1762	316+292	32.2 : 30.8%	192
1/3	Kennington Road Ahead	U	17	-	208	1775	307	67.7%	208
2/1	Ahead	U	74	-	435	1806	1302	33.4%	435
2/2	Ahead Ahead2	U	74	-	580	1806	1302	44.5%	580
2/3	Ahead	U	74	-	498	1806	1302	38.2%	498
2/4	Ahead	U	74	-	477	1806	1302	36.6%	477
J4: M20 Junction 10 / A292 Hythe Rd - East side (e84041)	-	-	-	-	-	-	-	66.4%	-

Full Input Data And Results

1/1	Hythe Road SB Ahead Left	U	40	-	353	1768	697	50.6%	353
1/2+1/3	Hythe Road SB Ahead	U	40	-	551	1841:1796	349+558	60.7 : 60.7%	551
2/1	Hythe Road	U	-	-	448	Inf	Inf	0.0%	448
2/2	Hythe Road	U	-	-	225	Inf	Inf	0.0%	225
3/1	Ahead	U	84	-	448	1800	1471	30.5%	448
3/2	Ahead	U	84	-	225	1800	1471	15.3%	225
4/1	Ahead	U	51	-	432	1806	903	47.8%	432
4/2	Right Ahead	U	51	-	600	1806	903	66.4%	600
4/3	Right	U	51	-	441	1806	903	48.8%	441
4/4	Right	U	51	-	244	1806	903	27.0%	244
5/1	M20 EB On-Slip	U	-	-	511	1940	1940	26.3%	511
5/2	M20 EB On-Slip	U	-	-	197	2080	2080	9.5%	197
Ped Link: P1	Unnamed Ped Link	-	0	-	0	-	0	0.0%	0
Ped Link: P2	Unnamed Ped Link	-	0	-	0	-	0	0.0%	0
Ped Link: P3	Unnamed Ped Link	-	0	-	0	-	0	0.0%	0
J5: M20 Junction 10 / M20 Westbound Off-Slip (e84042)	-	-	-	-	-	-	-	75.0%	-
1/1	Ahead	U	51	-	677	1806	903	75.0%	677
1/2	Ahead Right	U	51	-	653	1806	903	72.3%	653
1/3	Right	U	51	-	583	1806	903	64.6%	583
2/1	M20 WB Off-Slip Left	U	40	-	372	1729	682	54.6%	372
2/2+2/3	M20 WB Off-Slip Left Ahead	U	40	-	656	1751:1784	557+347	72.5 : 72.5%	656
J6: M20 Junction 10 / A2070 Bad Munstereifel Road (e84043)	-	-	-	-	-	-	-	74.7%	-
1/2+1/1	A2070 Bad Munstereifel Rd Left	U	48	-	519	1798:1798	719+706	36.4 : 36.4%	519
1/3+1/4	A2070 Bad Munstereifel Rd Left	U	48	-	935	1798:1798	562+735	72.1 : 72.1%	935
2/1	A2070 Ahead	U	83	-	1049	1800	1454	72.2%	1049

Full Input Data And Results

2/2	A2070 Ahead	U	83	-	616	1800	1454	42.4%	616
3/1	Ahead	U	42	-	441	1806	747	59.1%	441
3/2	Ahead	U	42	-	558	1806	747	74.7%	558
3/3	Ahead	U	42	-	277	1806	747	37.1%	277
4/1	Hythe Road Ahead Ahead2	U	-	-	698	1940	1940	36.0%	698
4/2	Hythe Road Ahead Ahead2	U	-	-	820	2080	2080	39.4%	820
5/1	Bad Munstereifel Rd	U	-	-	1049	Inf	Inf	0.0%	1049
5/2	Bad Munstereifel Rd	U	-	-	616	Inf	Inf	0.0%	616
Ped Link: P1	Unnamed Ped Link	-	0	-	0	-	0	0.0%	0
Ped Link: P2	Unnamed Ped Link	-	0	-	0	-	0	0.0%	0
Ped Link: P3	Unnamed Ped Link	-	0	-	0	-	0	0.0%	0
J7: M20 Junction 10 / A292 Hythe Road, M20 WB Onslip (e84044)	-	-	-	-	-	-	-	95.3%	-
1/1	M20 WB OnSlip Right	U	68	-	1145	1811	1202	95.3%	1145
2/1	M20 WB OnSlip	U	-	-	360	Inf	Inf	0.0%	360
2/2	M20 WB OnSlip	U	-	-	1145	Inf	Inf	0.0%	1145
3/2+3/1	A292 Hythe Rd Left Ahead	U	24	-	429	1940:1741	74+386	93.3 : 93.3%	429
3/3	A292 Hythe Rd Ahead	U	24	-	282	1940	466	60.5%	282
4/1	A292 Hythe Rd	U	-	-	373	Inf	Inf	0.0%	373
5/1	A292 Hythe Rd Ahead	U	85	-	373	1800	1488	25.1%	373
6/1	Hythe Road Ahead	U	-	-	69	Inf	Inf	0.0%	69
6/2	Hythe Road Ahead	U	-	-	282	Inf	Inf	0.0%	282
Ped Link: P1	Unnamed Ped Link	-	0	-	0	-	0	0.0%	0
Ped Link: P2	Unnamed Ped Link	-	0	-	0	-	0	0.0%	0
Ped Link: P3	Unnamed Ped Link	-	0	-	0	-	0	0.0%	0

Full Input Data And Results

Ped Link: P1	0	-	-	-	Inf	Inf	-	-	Inf
Ped Link: P2	0	-	-	-	Inf	Inf	-	-	Inf
Ped Link: P3	0	-	-	-	Inf	Inf	-	-	Inf
J7: M20 Junction 10 / A292 Hythe Road, M20 WB Onslip (e84044)	-	0	10.4	14.0	24.5	-	-	-	-
1/1	1145	-	3.1	7.9	11.1	34.7	31.4	7.9	39.3
2/1	360	-	0.0	0.0	0.0	0.0	0.0	0.0	0.0
2/2	1145	-	0.0	0.0	0.0	0.0	0.0	0.0	0.0
3/2+3/1	429	-	4.5	5.2	9.7	81.5	11.4	5.2	16.6
3/3	282	-	2.8	0.8	3.5	44.8	7.2	0.8	8.0
4/1	373	-	0.0	0.0	0.0	0.0	0.0	0.0	0.0
5/1	373	-	0.0	0.2	0.2	1.9	0.3	0.2	0.5
6/1	69	-	0.0	0.0	0.0	0.0	0.0	0.0	0.0
6/2	282	-	0.0	0.0	0.0	0.0	0.0	0.0	0.0
Ped Link: P1	0	-	-	-	Inf	Inf	-	-	Inf
Ped Link: P2	0	-	-	-	Inf	Inf	-	-	Inf
Ped Link: P3	0	-	-	-	Inf	Inf	-	-	Inf
C1 - e84038	PRC for Signalled Lanes (%):	36.4	Total Delay for Signalled Lanes (pcuHr):	10.76	Cycle Time (s):	104			
C2 - e84039	PRC for Signalled Lanes (%):	5.5	Total Delay for Signalled Lanes (pcuHr):	16.81	Cycle Time (s):	104			
C3 - e84040	PRC for Signalled Lanes (%):	32.9	Total Delay for Signalled Lanes (pcuHr):	9.43	Cycle Time (s):	104			
C4 - e84041	Stream: 1 PRC for Signalled Lanes (%):	35.4	Total Delay for Signalled Lanes (pcuHr):	18.40	Cycle Time (s):	104			
C4 - e84041	Stream: 2 PRC for Signalled Lanes (%):	195.5	Total Delay for Signalled Lanes (pcuHr):	0.36	Cycle Time (s):	104			
C5 - e84042	PRC for Signalled Lanes (%):	20.0	Total Delay for Signalled Lanes (pcuHr):	17.78	Cycle Time (s):	104			
C6 - e84043	Stream: 1 PRC for Signalled Lanes (%):	20.4	Total Delay for Signalled Lanes (pcuHr):	18.50	Cycle Time (s):	104			
C6 - e84043	Stream: 2 PRC for Signalled Lanes (%):	24.7	Total Delay for Signalled Lanes (pcuHr):	2.02	Cycle Time (s):	104			
C7 - e84044	PRC for Signalled Lanes (%):	-5.9	Total Delay for Signalled Lanes (pcuHr):	24.48	Cycle Time (s):	104			
	PRC Over All Lanes (%):	-5.9	Total Delay Over All Lanes(pcuHr):	119.66					

Full Input Data And Results

Scenario 2: 'Base PM' (FG2: 'PM Peak 2018', Plan 1: 'Network Control Plan 1')

Item	Lane Description	Lane Type	Total Green (s)	Arrow Green (s)	Demand Flow (pcu)	Sat Flow (pcu/Hr)	Capacity (pcu)	Deg Sat (%)	Arriving (pcu)
Network: J1 M20Junction 10	-	-	-	-	-	-	-	86.7%	-
J1: M20 Junction 10 / A292 Hythe Road - West side (e84038)	-	-	-	-	-	-	-	63.1%	-
1/1	Right	U	58	-	598	1806	1025	58.4%	598
1/2	Right	U	58	-	539	1806	1025	52.6%	539
2/2+2/1	Hythe Road EB Left	U	34	-	401	1767:1737	89+546	63.1 : 63.1%	401
J2: M20 Junction 10 / M20 EB Offslip (e84039)	-	-	-	-	-	-	-	82.0%	-
1/1	Kennington Road	U	-	-	334	1940	1940	17.2%	334
1/2	Kennington Road	U	-	-	133	2080	2080	6.4%	133
2/2+2/1	M20 EB Off-Slip Ahead Left	U	42	-	894	1804:1796	600+490	82.0 : 82.0%	894
2/3	M20 EB Off-Slip Ahead	U	42	-	588	1747	722	81.4%	588
3/1	Right Ahead	U	49	-	694	1806	868	79.9%	694
3/2	Right	U	49	-	622	1806	868	71.6%	622
3/3	Right	U	49	-	222	1806	868	25.6%	222
J3: M20 Junction 10 / A2070 Kennington Road (e84040)	-	-	-	-	-	-	-	70.9%	-
1/2+1/1	Kennington Road Left Ahead	U	20	-	385	1828:1762	273+356	61.3 : 61.3%	385
1/3	Kennington Road Ahead	U	20	-	254	1775	358	70.9%	254
2/1	Ahead	U	71	-	653	1806	1250	52.2%	653
2/2	Ahead Ahead2	U	71	-	641	1806	1250	51.3%	641
2/3	Ahead	U	71	-	624	1806	1250	49.9%	624
2/4	Ahead	U	71	-	635	1806	1250	50.8%	635
J4: M20 Junction 10 / A292 Hythe Rd - East side (e84041)	-	-	-	-	-	-	-	76.4%	-
1/1	Hythe Road SB Ahead Left	U	24	-	257	1768	425	60.5%	257

Full Input Data And Results

1/2+1/3	Hythe Road SB Ahead	U	24	-	546	1841:1796	339+376	76.4 : 76.4%	546
2/1	Hythe Road	U	-	-	653	Inf	Inf	0.0%	653
2/2	Hythe Road	U	-	-	214	Inf	Inf	0.0%	214
3/1	Ahead	U	84	-	653	1800	1471	44.4%	653
3/2	Ahead	U	84	-	214	1800	1471	14.5%	214
4/1	Ahead	U	67	-	645	1806	1181	54.6%	645
4/2	Right Ahead	U	67	-	791	1806	1181	67.0%	791
4/3	Right	U	67	-	592	1806	1181	50.1%	592
4/4	Right	U	67	-	297	1806	1181	25.2%	297
5/1	M20 EB On-Slip	U	-	-	737	1940	1940	38.0%	737
5/2	M20 EB On-Slip	U	-	-	167	2080	2080	8.0%	167
Ped Link: P1	Unnamed Ped Link	-	0	-	0	-	0	0.0%	0
Ped Link: P2	Unnamed Ped Link	-	0	-	0	-	0	0.0%	0
Ped Link: P3	Unnamed Ped Link	-	0	-	0	-	0	0.0%	0
J5: M20 Junction 10 / M20 Westbound Off-Slip (e84042)	-	-	-	-	-	-	-	78.9%	-
1/1	Ahead	U	65	-	789	1806	1146	68.8%	789
1/2	Ahead Right	U	65	-	851	1806	1146	74.3%	851
1/3	Right	U	65	-	584	1806	1146	51.0%	584
2/1	M20 WB Off-Slip Left	U	26	-	306	1729	449	68.2%	306
2/2+2/3	M20 WB Off-Slip Left Ahead	U	26	-	448	1751:1784	427+141	78.9 : 78.9%	448
J6: M20 Junction 10 / A2070 Bad Munstereifel Road (e84043)	-	-	-	-	-	-	-	75.3%	-
1/2+1/1	A2070 Bad Munstereifel Rd Left	U	49	-	738	1798:1798	723+727	50.9 : 50.9%	738
1/3+1/4	A2070 Bad Munstereifel Rd Left	U	49	-	982	1798:1798	611+740	72.7 : 72.7%	982
2/1	A2070 Ahead	U	83	-	1095	1800	1454	75.3%	1095
2/2	A2070 Ahead	U	83	-	820	1800	1454	56.4%	820
3/1	Ahead	U	41	-	368	1806	729	50.5%	368

Full Input Data And Results

3/2	Ahead	U	41	-	540	1806	729	74.0%	540
3/3	Ahead	U	41	-	155	1806	729	21.3%	155
4/1	Hythe Road Ahead Ahead2	U	-	-	738	1940	1940	38.0%	738
4/2	Hythe Road Ahead Ahead2	U	-	-	908	2080	2080	43.7%	908
5/1	Bad Munstereifel Rd	U	-	-	1095	Inf	Inf	0.0%	1095
5/2	Bad Munstereifel Rd	U	-	-	820	Inf	Inf	0.0%	820
Ped Link: P1	Unnamed Ped Link	-	0	-	0	-	0	0.0%	0
Ped Link: P2	Unnamed Ped Link	-	0	-	0	-	0	0.0%	0
Ped Link: P3	Unnamed Ped Link	-	0	-	0	-	0	0.0%	0
J7: M20 Junction 10 / A292 Hythe Road, M20 WB Onslip (e84044)	-	-	-	-	-	-	-	86.7%	-
1/1	M20 WB OnSlip Right	U	70	-	1072	1811	1236	86.7%	1072
2/1	M20 WB OnSlip	U	-	-	261	Inf	Inf	0.0%	261
2/2	M20 WB OnSlip	U	-	-	1072	Inf	Inf	0.0%	1072
3/2+3/1	A292 Hythe Rd Left Ahead	U	22	-	342	1940:1741	105+338	77.2 : 77.2%	342
3/3	A292 Hythe Rd Ahead	U	22	-	320	1940	429	74.6%	320
4/1	A292 Hythe Rd	U	-	-	574	Inf	Inf	0.0%	574
5/1	A292 Hythe Rd Ahead	U	85	-	574	1800	1488	38.6%	574
6/1	Hythe Road Ahead	U	-	-	81	Inf	Inf	0.0%	81
6/2	Hythe Road Ahead	U	-	-	320	Inf	Inf	0.0%	320
Ped Link: P1	Unnamed Ped Link	-	0	-	0	-	0	0.0%	0
Ped Link: P2	Unnamed Ped Link	-	0	-	0	-	0	0.0%	0
Ped Link: P3	Unnamed Ped Link	-	0	-	0	-	0	0.0%	0

Full Input Data And Results

Ped Link: P1	0	-	-	-	Inf	Inf	-	-	Inf																																																																						
Ped Link: P2	0	-	-	-	Inf	Inf	-	-	Inf																																																																						
Ped Link: P3	0	-	-	-	Inf	Inf	-	-	Inf																																																																						
J7: M20 Junction 10 / A292 Hythe Road, M20 WB Onslip (e84044)	-	0	9.4	6.5	15.9	-	-	-	-																																																																						
1/1	1072	-	2.4	3.1	5.6	18.7	25.2	3.1	28.4																																																																						
2/1	261	-	0.0	0.0	0.0	0.0	0.0	0.0	0.0																																																																						
2/2	1072	-	0.0	0.0	0.0	0.0	0.0	0.0	0.0																																																																						
3/2+3/1	342	-	3.5	1.6	5.2	54.2	8.0	1.6	9.7																																																																						
3/3	320	-	3.4	1.4	4.8	53.9	8.6	1.4	10.1																																																																						
4/1	574	-	0.0	0.0	0.0	0.0	0.0	0.0	0.0																																																																						
5/1	574	-	0.1	0.3	0.4	2.6	1.6	0.3	1.9																																																																						
6/1	81	-	0.0	0.0	0.0	0.0	0.0	0.0	0.0																																																																						
6/2	320	-	0.0	0.0	0.0	0.0	0.0	0.0	0.0																																																																						
Ped Link: P1	0	-	-	-	Inf	Inf	-	-	Inf																																																																						
Ped Link: P2	0	-	-	-	Inf	Inf	-	-	Inf																																																																						
Ped Link: P3	0	-	-	-	Inf	Inf	-	-	Inf																																																																						
<table border="0"> <tbody> <tr> <td>C1 - e84038</td> <td>PRC for Signalled Lanes (%):</td> <td>42.5</td> <td>Total Delay for Signalled Lanes (pcuHr):</td> <td>12.83</td> <td>Cycle Time (s):</td> <td>104</td> </tr> <tr> <td>C2 - e84039</td> <td>PRC for Signalled Lanes (%):</td> <td>9.7</td> <td>Total Delay for Signalled Lanes (pcuHr):</td> <td>21.10</td> <td>Cycle Time (s):</td> <td>104</td> </tr> <tr> <td>C3 - e84040</td> <td>PRC for Signalled Lanes (%):</td> <td>27.0</td> <td>Total Delay for Signalled Lanes (pcuHr):</td> <td>18.22</td> <td>Cycle Time (s):</td> <td>104</td> </tr> <tr> <td>C4 - e84041</td> <td>Stream: 1 PRC for Signalled Lanes (%):</td> <td>17.9</td> <td>Total Delay for Signalled Lanes (pcuHr):</td> <td>19.77</td> <td>Cycle Time (s):</td> <td>104</td> </tr> <tr> <td>C4 - e84041</td> <td>Stream: 2 PRC for Signalled Lanes (%):</td> <td>102.8</td> <td>Total Delay for Signalled Lanes (pcuHr):</td> <td>0.55</td> <td>Cycle Time (s):</td> <td>104</td> </tr> <tr> <td>C5 - e84042</td> <td>PRC for Signalled Lanes (%):</td> <td>14.1</td> <td>Total Delay for Signalled Lanes (pcuHr):</td> <td>17.04</td> <td>Cycle Time (s):</td> <td>104</td> </tr> <tr> <td>C6 - e84043</td> <td>Stream: 1 PRC for Signalled Lanes (%):</td> <td>21.6</td> <td>Total Delay for Signalled Lanes (pcuHr):</td> <td>14.81</td> <td>Cycle Time (s):</td> <td>104</td> </tr> <tr> <td>C6 - e84043</td> <td>Stream: 2 PRC for Signalled Lanes (%):</td> <td>19.5</td> <td>Total Delay for Signalled Lanes (pcuHr):</td> <td>2.67</td> <td>Cycle Time (s):</td> <td>104</td> </tr> <tr> <td>C7 - e84044</td> <td>PRC for Signalled Lanes (%):</td> <td>3.8</td> <td>Total Delay for Signalled Lanes (pcuHr):</td> <td>15.92</td> <td>Cycle Time (s):</td> <td>104</td> </tr> <tr> <td></td> <td>PRC Over All Lanes (%):</td> <td>3.8</td> <td>Total Delay Over All Lanes(pcuHr):</td> <td>124.11</td> <td></td> <td></td> </tr> </tbody> </table>										C1 - e84038	PRC for Signalled Lanes (%):	42.5	Total Delay for Signalled Lanes (pcuHr):	12.83	Cycle Time (s):	104	C2 - e84039	PRC for Signalled Lanes (%):	9.7	Total Delay for Signalled Lanes (pcuHr):	21.10	Cycle Time (s):	104	C3 - e84040	PRC for Signalled Lanes (%):	27.0	Total Delay for Signalled Lanes (pcuHr):	18.22	Cycle Time (s):	104	C4 - e84041	Stream: 1 PRC for Signalled Lanes (%):	17.9	Total Delay for Signalled Lanes (pcuHr):	19.77	Cycle Time (s):	104	C4 - e84041	Stream: 2 PRC for Signalled Lanes (%):	102.8	Total Delay for Signalled Lanes (pcuHr):	0.55	Cycle Time (s):	104	C5 - e84042	PRC for Signalled Lanes (%):	14.1	Total Delay for Signalled Lanes (pcuHr):	17.04	Cycle Time (s):	104	C6 - e84043	Stream: 1 PRC for Signalled Lanes (%):	21.6	Total Delay for Signalled Lanes (pcuHr):	14.81	Cycle Time (s):	104	C6 - e84043	Stream: 2 PRC for Signalled Lanes (%):	19.5	Total Delay for Signalled Lanes (pcuHr):	2.67	Cycle Time (s):	104	C7 - e84044	PRC for Signalled Lanes (%):	3.8	Total Delay for Signalled Lanes (pcuHr):	15.92	Cycle Time (s):	104		PRC Over All Lanes (%):	3.8	Total Delay Over All Lanes(pcuHr):	124.11		
C1 - e84038	PRC for Signalled Lanes (%):	42.5	Total Delay for Signalled Lanes (pcuHr):	12.83	Cycle Time (s):	104																																																																									
C2 - e84039	PRC for Signalled Lanes (%):	9.7	Total Delay for Signalled Lanes (pcuHr):	21.10	Cycle Time (s):	104																																																																									
C3 - e84040	PRC for Signalled Lanes (%):	27.0	Total Delay for Signalled Lanes (pcuHr):	18.22	Cycle Time (s):	104																																																																									
C4 - e84041	Stream: 1 PRC for Signalled Lanes (%):	17.9	Total Delay for Signalled Lanes (pcuHr):	19.77	Cycle Time (s):	104																																																																									
C4 - e84041	Stream: 2 PRC for Signalled Lanes (%):	102.8	Total Delay for Signalled Lanes (pcuHr):	0.55	Cycle Time (s):	104																																																																									
C5 - e84042	PRC for Signalled Lanes (%):	14.1	Total Delay for Signalled Lanes (pcuHr):	17.04	Cycle Time (s):	104																																																																									
C6 - e84043	Stream: 1 PRC for Signalled Lanes (%):	21.6	Total Delay for Signalled Lanes (pcuHr):	14.81	Cycle Time (s):	104																																																																									
C6 - e84043	Stream: 2 PRC for Signalled Lanes (%):	19.5	Total Delay for Signalled Lanes (pcuHr):	2.67	Cycle Time (s):	104																																																																									
C7 - e84044	PRC for Signalled Lanes (%):	3.8	Total Delay for Signalled Lanes (pcuHr):	15.92	Cycle Time (s):	104																																																																									
	PRC Over All Lanes (%):	3.8	Total Delay Over All Lanes(pcuHr):	124.11																																																																											

F.2 J2_M20 J11

Junctions 9
ARCADY 9 - Roundabout Module
Version: 9.0.2.5947 © Copyright TRL Limited, 2017
For sales and distribution information, program advice and maintenance, contact TRL: +44 (0)1344 770558 software@trl.co.uk www.trlsoftware.co.uk
The users of this computer program for the solution of an engineering problem are in no way relieved of their responsibility for the correctness of the solution

Filename: J2_M20 J11 B2048 A20_Base Model.j9
Path: K:\UA008926 Otterpool\D-Calcs\Modelling\DM_it5\Appendix\Appendix Base Models\Arcady\J2 M20-J11-A20
Report generation date: 20/11/2018 15:26:18

- »Base, AM
- »Base, PM

Summary of junction performance

	AM				PM			
	Queue (Veh)	Delay (s)	RFC	LOS	Queue (Veh)	Delay (s)	RFC	LOS
	Base							
Arm A	0.5	2.87	0.34	A	0.5	3.57	0.34	A
Arm B	0.7	2.19	0.40	A	0.5	1.92	0.32	A
Arm C	0.2	4.05	0.15	A	0.1	3.25	0.13	A
Arm D	0.4	3.44	0.28	A	0.8	4.22	0.45	A
Arm E	0.3	3.09	0.24	A	0.5	4.16	0.32	A

Values shown are the highest values encountered over all time segments. Delay is the maximum value of average delay per arriving vehicle.

File summary

File Description

Title	J2 Otterpool Park_Base Model AM PEAK
Location	M20 J11, B2068-A20
Site number	
Date	27/06/2017
Version	
Status	Base Model
Identifier	
Client	
Jobnumber	
Enumerator	dma78191 [C8Z9W0G2]
Description	

Units

Distance units	Speed units	Traffic units input	Traffic units results	Flow units	Average delay units	Total delay units	Rate of delay units
m	kph	Veh	Veh	perHour	s	-Hour	perHour

Analysis Options

Vehicle length (m)	Calculate Queue Percentiles	Calculate detailed queueing delay	Calculate residual capacity	RFC Threshold	Average Delay threshold (s)	Queue threshold (PCU)
5.75				0.85	36.00	20.00

Demand Set Summary

ID	Scenario name	Time Period name	Traffic profile type	Start time (HH:mm)	Finish time (HH:mm)	Time segment length (min)	Run automatically
D1	Base	AM	ONE HOUR	07:45	09:15	15	9
D2	Base	PM	ONE HOUR	16:30	18:00	15	9

Analysis Set Details

ID	Include in report	Network flow scaling factor (%)	Network capacity scaling factor (%)
A1	9	100.000	100.000

Base, AM

Data Errors and Warnings

No errors or warnings

Junction Network

Junctions

Junction	Name	Junction Type	Arm order	Junction Delay (s)	Junction LOS
1	untitled	Large Roundabout	A, B, C, D, E	2.80	A

Junction Network Options

Driving side	Lighting
Left	Normal/unknown

Arms

Arms

Arm	Name	Description
A	M20 OffSlip Westbound	
B	A20 Ashford Road	
C	Services	
D	M20 OffSlip Eastbound	
E	B2068	

Roundabout Geometry

Arm	V - Approach road half - width (m)	E - Entry width (m)	l' - Effective flare length (m)	R - Entry radius (m)	D - Inscribed circle diameter (m)	PHI - Conflict (entry) angle (deg)	Exit only
A	5.38	7.20	28.0	64.6	226.8	21.0	
B	5.44	9.46	29.3	41.6	223.0	23.0	
C	3.98	7.14	27.1	28.9	223.0	41.0	
D	5.53	6.09	25.5	49.2	226.0	18.0	
E	3.08	6.63	25.5	41.4	223.0	31.0	

Large Roundabout Data

Arm	Circulating flow (PCU/hr)	Entry to-exit separation (m)
A	540	105.00
B	240	49.60
C	1140	33.90
D	720	108.00
E	720	42.00

Slope / Intercept / Capacity

Roundabout Slope and Intercept used in model

Arm	Final slope	Final intercept (PCU/hr)
A	1.028	2740
B	1.195	3327
C	0.788	2390
D	0.926	2432
E	0.843	2324

The slope and intercept shown above include any corrections and adjustments.

Traffic Demand

Demand Set Details

ID	Scenario name	Time Period name	Traffic profile type	Start time (HH:mm)	Finish time (HH:mm)	Time segment length (min)	Run automatically
D1	Base	AM	ONE HOUR	07:45	09:15	15	9

Vehicle mix varies over turn	Vehicle mix varies over entry	Vehicle mix source	PCU Factor for a HV (PCU)
9	9	HV Percentages	2.00

Demand overview (Traffic)

Arm	Linked arm	Profile type	Use O-D data	Average Demand (Veh/hr)	Scaling Factor (%)
A		ONE HOUR	9	596	100.000
B		ONE HOUR	9	983	100.000
C		ONE HOUR	9	144	100.000
D		ONE HOUR	9	373	100.000
E		ONE HOUR	9	326	100.000

Origin -Destination Data

Demand (Veh/hr)

		To					
		\$	%	&	'	(
From	\$	5	434	49	1	107	
	%	305	55	37	403	183	
	&	47	17	0	72	8	
	'	1	266	26	1	79	
	(132	109	7	78	0	

Vehicle Mix

Heavy Vehicle Percentages

		To					
		\$	%	&	'	(
From	\$	0	5	31	0	7	
	%	12	9	3	6	2	
	&	26	0	0	36	13	
	'	100	9	42	0	9	
	(2	4	0	4	0	

Results

Results Summary for whole modelled period

Arm	Max RFC	Max delay (s)	Max Queue (Veh)	Max LOS	Average Demand (Veh/hr)	Total Junction Arrivals (Veh)
A	0.34	2.87	0.5	A	547	820
B	0.40	2.19	0.7	A	902	1353
C	0.15	4.05	0.2	A	132	198
D	0.28	3.44	0.4	A	342	513
E	0.24	3.09	0.3	A	299	449

Main Results for each time segment

07:45 - 08:00

Arm	Total Demand (Veh/hr)	Junction Arrivals (Veh)	Circulating flow (Veh/hr)	Capacity (Veh/hr)	RFC	Throughput (Veh/hr)	Throughput (exit side) (Veh/hr)	Start queue (Veh)	End queue (Veh)	Delay (s)	LOS
A	449	112	420	2115	0.212	448	368	0.0	0.3	2.158	A
B	740	185	206	2845	0.260	739	662	0.0	0.4	1.709	A
C	108	27	855	1312	0.083	108	89	0.0	0.1	2.991	A
D	281	70	546	1686	0.167	280	417	0.0	0.2	2.559	A
E	245	61	543	1755	0.140	245	283	0.0	0.2	2.382	A

08:00 - 08:15

Arm	Total Demand (Veh/hr)	Junction Arrivals (Veh)	Circulating flow (Veh/hr)	Capacity (Veh/hr)	RFC	Throughput (Veh/hr)	Throughput (exit side) (Veh/hr)	Start queue (Veh)	End queue (Veh)	Delay (s)	LOS
A	536	134	502	2029	0.264	535	440	0.3	0.4	2.410	A
B	884	221	246	2793	0.316	883	791	0.4	0.5	1.884	A
C	129	32	1022	1201	0.108	129	107	0.1	0.1	3.359	A
D	335	84	653	1589	0.211	335	499	0.2	0.3	2.870	A
E	293	73	650	1657	0.177	293	339	0.2	0.2	2.638	A

08:15 - 08:30

Arm	Total Demand (Veh/hr)	Junction Arrivals (Veh)	Circulating flow (Veh/hr)	Capacity (Veh/hr)	RFC	Throughput (Veh/hr)	Throughput (exit side) (Veh/hr)	Start queue (Veh)	End queue (Veh)	Delay (s)	LOS
A	656	164	615	1912	0.343	656	539	0.4	0.5	2.863	A
B	1082	271	301	2724	0.397	1082	969	0.5	0.7	2.191	A
C	159	40	1252	1048	0.151	158	131	0.1	0.2	4.043	A
D	411	103	800	1456	0.282	410	611	0.3	0.4	3.439	A
E	359	90	795	1523	0.236	359	415	0.2	0.3	3.090	A

08:30 - 08:45

Arm	Total Demand (Veh/hr)	Junction Arrivals (Veh)	Circulating flow (Veh/hr)	Capacity (Veh/hr)	RFC	Throughput (Veh/hr)	Throughput (exit side) (Veh/hr)	Start queue (Veh)	End queue (Veh)	Delay (s)	LOS
A	656	164	615	1912	0.343	656	539	0.5	0.5	2.866	A
B	1082	271	302	2723	0.397	1082	970	0.7	0.7	2.193	A
C	159	40	1253	1048	0.151	159	131	0.2	0.2	4.048	A
D	411	103	800	1456	0.282	411	611	0.4	0.4	3.444	A
E	359	90	796	1523	0.236	359	415	0.3	0.3	3.092	A

08:45 - 09:00

Arm	Total Demand (Veh/hr)	Junction Arrivals (Veh)	Circulating flow (Veh/hr)	Capacity (Veh/hr)	RFC	Throughput (Veh/hr)	Throughput (exit side) (Veh/hr)	Start queue (Veh)	End queue (Veh)	Delay (s)	LOS
A	536	134	503	2028	0.264	536	441	0.5	0.4	2.415	A
B	884	221	247	2793	0.316	884	793	0.7	0.5	1.886	A
C	129	32	1024	1200	0.108	130	107	0.2	0.1	3.364	A
D	335	84	654	1588	0.211	336	499	0.4	0.3	2.875	A
E	293	73	651	1656	0.177	293	339	0.3	0.2	2.641	A

09:00 - 09:15

Arm	Total Demand (Veh/hr)	Junction Arrivals (Veh)	Circulating flow (Veh/hr)	Capacity (Veh/hr)	RFC	Throughput (Veh/hr)	Throughput (exit side) (Veh/hr)	Start queue (Veh)	End queue (Veh)	Delay (s)	LOS
A	449	112	421	2113	0.212	449	369	0.4	0.3	2.165	A
B	740	185	206	2844	0.260	740	664	0.5	0.4	1.711	A
C	108	27	857	1310	0.083	109	90	0.1	0.1	2.995	A
D	281	70	548	1685	0.167	281	418	0.3	0.2	2.564	A
E	245	61	545	1754	0.140	246	284	0.2	0.2	2.389	A

Base, PM

Data Errors and Warnings

No errors or warnings

Junction Network

Junctions

Junction	Name	Junction Type	Arm order	Junction Delay (s)	Junction LOS
1	untitled	Large Roundabout	A, B, C, D, E	3.27	A

Junction Network Options

Driving side	Lighting
Left	Normal/unknown

Arms

Arms

[same as above]

Roundabout Geometry

[same as above]

Large Roundabout Data

Arm	Circulating flow (PCU/hr)	Entry to -exit separation (m)
A	540	105.00
B	240	49.60
C	1140	33.90
D	720	108.00
E	720	42.00

Slope / Intercept / Capacity

[same as above]

Traffic Demand

Demand Set Details

ID	Scenario name	Time Period name	Traffic profile type	Start time (HH:mm)	Finish time (HH:mm)	Time segment length (min)	Run automatically
D2	Base	PM	ONE HOUR	16:30	18:00	15	9

Vehicle mix varies over turn	Vehicle mix varies over entry	Vehicle mix source	PCU Factor for a HV (PCU)
9	9	HV Percentages	2.00

Demand overview (Traffic)

Arm	Linked arm	Profile type	Use O-D data	Average Demand (Veh/hr)	Scaling Factor (%)
A		ONE HOUR	9	482	100.000
B		ONE HOUR	9	807	100.000
C		ONE HOUR	9	145	100.000
D		ONE HOUR	9	636	100.000
E		ONE HOUR	9	363	100.000

Origin -Destination Data

Demand (Veh/hr)

From	To					
	\$	%	&	'	(
	5	325	57	0	95	
	353	63	38	237	116	
	48	27	0	57	13	
	1	475	52	9	99	
	110	159	10	84	0	

Vehicle Mix

Heavy Vehicle Percentages

From	To					
	\$	%	&	'	(
	20	7	40	0	0	
	3	0	8	4	0	
	33	7	0	21	8	
	0	3	52	0	5	
	3	1	20	4	0	

Results

Results Summary for whole modelled period

Arm	Max RFC	Max delay (s)	Max Queue (Veh)	Max LOS	Average Demand (Veh/hr)	Total Junction Arrivals (Veh)
A	0.34	3.57	0.5	A	442	663
B	0.32	1.92	0.5	A	741	1111
C	0.13	3.25	0.1	A	133	200
D	0.45	4.22	0.8	A	584	875
E	0.32	4.16	0.5	A	333	500

Main Results for each time segment

16:30 - 16:45

Arm	Total Demand (Veh/hr)	Junction Arrivals (Veh)	Circulating flow (Veh/hr)	Capacity (Veh/hr)	RFC	Throughput (Veh/hr)	Throughput (exit side) (Veh/hr)	Start queue (Veh)	End queue (Veh)	Delay (s)	LOS
A	363	91	660	1845	0.197	362	388	0.0	0.2	2.426	A
B	608	152	234	2914	0.209	606	787	0.0	0.3	1.560	A
C	109	27	723	1490	0.073	109	118	0.0	0.1	2.606	A
D	479	120	541	1781	0.269	477	291	0.0	0.4	2.760	A
E	273	68	776	1581	0.173	272	243	0.0	0.2	2.750	A

16:45 - 17:00

Arm	Total Demand (Veh/hr)	Junction Arrivals (Veh)	Circulating flow (Veh/hr)	Capacity (Veh/hr)	RFC	Throughput (Veh/hr)	Throughput (exit side) (Veh/hr)	Start queue (Veh)	End queue (Veh)	Delay (s)	LOS
A	433	108	789	1717	0.252	433	465	0.2	0.3	2.804	A
B	725	181	280	2851	0.255	725	942	0.3	0.3	1.693	A
C	130	33	864	1395	0.093	130	141	0.1	0.1	2.844	A
D	572	143	647	1685	0.339	571	348	0.4	0.5	3.230	A
E	326	82	928	1448	0.225	326	290	0.2	0.3	3.209	A

17:00 - 17:15

Arm	Total Demand (Veh/hr)	Junction Arrivals (Veh)	Circulating flow (Veh/hr)	Capacity (Veh/hr)	RFC	Throughput (Veh/hr)	Throughput (exit side) (Veh/hr)	Start queue (Veh)	End queue (Veh)	Delay (s)	LOS
A	531	133	966	1542	0.344	530	569	0.3	0.5	3.557	A
B	889	222	343	2765	0.321	888	1153	0.3	0.5	1.917	A
C	160	40	1058	1266	0.126	159	173	0.1	0.1	3.252	A
D	700	175	792	1554	0.450	699	426	0.5	0.8	4.202	A
E	400	100	1136	1265	0.316	399	355	0.3	0.5	4.148	A

17:15 - 17:30

Arm	Total Demand (Veh/hr)	Junction Arrivals (Veh)	Circulating flow (Veh/hr)	Capacity (Veh/hr)	RFC	Throughput (Veh/hr)	Throughput (exit side) (Veh/hr)	Start queue (Veh)	End queue (Veh)	Delay (s)	LOS
A	531	133	968	1540	0.345	531	569	0.5	0.5	3.565	A
B	889	222	344	2764	0.321	889	1155	0.5	0.5	1.918	A
C	160	40	1059	1266	0.126	160	173	0.1	0.1	3.254	A
D	700	175	793	1554	0.451	700	426	0.8	0.8	4.216	A
E	400	100	1137	1264	0.316	400	356	0.5	0.5	4.163	A

17:30 - 17:45

Arm	Total Demand (Veh/hr)	Junction Arrivals (Veh)	Circulating flow (Veh/hr)	Capacity (Veh/hr)	RFC	Throughput (Veh/hr)	Throughput (exit side) (Veh/hr)	Start queue (Veh)	End queue (Veh)	Delay (s)	LOS
A	433	108	792	1714	0.253	434	465	0.5	0.3	2.815	A
B	725	181	281	2849	0.255	726	945	0.5	0.3	1.694	A
C	130	33	866	1395	0.093	131	141	0.1	0.1	2.849	A
D	572	143	648	1684	0.339	573	348	0.8	0.5	3.242	A
E	326	82	930	1446	0.226	327	291	0.5	0.3	3.221	A

17:45 - 18:00

Arm	Total Demand (Veh/hr)	Junction Arrivals (Veh)	Circulating flow (Veh/hr)	Capacity (Veh/hr)	RFC	Throughput (Veh/hr)	Throughput (exit side) (Veh/hr)	Start queue (Veh)	End queue (Veh)	Delay (s)	LOS
A	363	91	663	1842	0.197	363	390	0.3	0.2	2.435	A
B	608	152	235	2912	0.209	608	791	0.3	0.3	1.561	A
C	109	27	725	1489	0.073	109	118	0.1	0.1	2.611	A
D	479	120	542	1779	0.269	479	292	0.5	0.4	2.770	A
E	273	68	778	1579	0.173	274	243	0.3	0.2	2.760	A

F.3 J3_A20 Ashford Rd Swan Ln

Junctions 9
PICADY 9 - Priority Intersection Module
Version: 9.0.2.5947 © Copyright TRL Limited, 2017
For sales and distribution information, program advice and maintenance, contact TRL: +44 (0)1344 770558 software@trl.co.uk www.trlsoftware.co.uk
The users of this computer program for the solution of an engineering problem are in no way relieved of their responsibility for the correctness of the solution

Filename: J3_A20 Ashford Rd Swan Ln_Base Model.j9

Path: K:\UA008926 Otterpool\D-Calcs\Modelling\DM_it5\Appendix\Appendix Base Models\Picady\J3 A20 Ashford Rd - Swan Ln

Report generation date: 20/11/2018 15:35:37

»Base, AM

»Base, PM

Summary of junction performance

	AM				PM			
	Queue (Veh)	Delay (s)	RFC	LOS	Queue (Veh)	Delay (s)	RFC	LOS
Base								
Stream B-ACD	0.0	8.16	0.02	A	0.0	0.00	0.00	A
Stream A-BCD	0.1	6.54	0.05	A	0.1	7.32	0.12	A
Stream D-ABC	0.6	14.83	0.40	B	0.4	12.62	0.29	B
Stream C-ABD	0.0	6.52	0.00	A	0.0	6.39	0.01	A

Values shown are the highest values encountered over all time segments. Delay is the maximum value of average delay per arriving vehicle.

File summary

File Description

Title	J3 Otterpool Park_Base Model
Location	A20 Ashford Road - Swan Ln
Site number	
Date	27/06/2017
Version	
Status	Draft 1
Identifier	
Client	
Jobnumber	
Enumerator	dma78191 [C8Z9W0G2]
Description	

Units

Distance units	Speed units	Traffic units input	Traffic units results	Flow units	Average delay units	Total delay units	Rate of delay units
m	kph	Veh	Veh	perHour	s	-Hour	perHour

Analysis Options

Vehicle length (m)	Calculate Queue Percentiles	Calculate detailed queueing delay	Calculate residual capacity	RFC Threshold	Average Delay threshold (s)	Queue threshold (PCU)
5.75				0.85	36.00	20.00

Demand Set Summary

ID	Scenario name	Time Period name	Description	Traffic profile type	Start time (HH:mm)	Finish time (HH:mm)	Time segment length (min)	Run automatically
D1	Base	AM	J3 Otterpool Park AM PEAK	ONE HOUR	07:45	09:15	15	9
D2	Base	PM	J3 Otterpool Park PM PEAK	ONE HOUR	16:45	18:15	15	9

Analysis Set Details

ID	Include in report	Network flow scaling factor (%)	Network capacity scaling factor (%)
A1	9	100.000	100.000

Base, AM

Data Errors and Warnings

No errors or warnings

Junction Network

Junctions

Junction	Name	Junction Type	Major road direction	Junction Delay (s)	Junction LOS
1	untitled	Crossroads	Two-way	3.07	A

Junction Network Options

Driving side	Lighting
Left	Normal/unknown

Arms

Arms

Arm	Name	Description	Arm type
A	A20 Ashford Road Westbound		Major
B	Private Access		Minor
C	A20 Ashford Road Eastbound		Major
D	Swan Ln		Minor

Major Arm Geometry

Arm	Width of carriageway (m)	Has kerbed central reserve	Has right turn bay	Visibility for right turn (m)	Blocks?	Blocking queue (PCU)
A	6.90			120.0	9	1.00
C	6.90			120.0	9	1.00

Geometries for Arm C are measured opposite Arm B. Geometries for Arm A (if relevant) are measured opposite Arm D.

Minor Arm Geometry

Arm	Minor arm type	Lane width (m)	Visibility to left (m)	Visibility to right (m)
B	One lane	2.20	35	35
D	One lane	2.70	23	43

Slope / Intercept / Capacity

Priority Intersection Slopes and Intercepts

Junction	Stream	Intercept (Veh/hr)	Slope for A-B	Slope for A-C	Slope for A-D	Slope for B-A	Slope for B-C	Slope for B-D	Slope for C-A	Slope for C-B	Slope for C-D	Slope for D-A	Slope for D-B	Slope for D-C
1	A-D	643	-	-	-	-	-	-	0.240	0.342	0.240	-	-	-
1	B-A	466	0.081	0.206	0.206	-	-	-	0.130	0.294	-	0.206	0.206	0.103
1	B-C	594	0.088	0.221	-	-	-	-	-	-	-	-	-	-
1	B-D, nearside lane	466	0.081	0.206	0.206	-	-	-	0.130	0.294	0.130	-	-	-
1	B-D, offside lane	466	0.081	0.206	0.206	-	-	-	0.130	0.294	0.130	-	-	-
1	C-B	643	0.240	0.240	0.342	-	-	-	-	-	-	-	-	-
1	D-A	631	-	-	-	-	-	-	0.235	-	0.093	-	-	-
1	D-B, nearside lane	491	0.137	0.137	0.310	-	-	-	0.217	0.217	0.086	-	-	-
1	D-B, offside lane	491	0.137	0.137	0.310	-	-	-	0.217	0.217	0.086	-	-	-
1	D-C	491	-	0.137	0.310	0.109	0.217	0.217	0.217	0.217	0.086	-	-	-

The slopes and intercepts shown above do NOT include any corrections or adjustments.

Streams may be combined, in which case capacity will be adjusted.

Values are shown for the first time segment only; they may differ for subsequent time segments.

Traffic Demand

Demand Set Details

ID	Scenario name	Time Period name	Description	Traffic profile type	Start time (HH:mm)	Finish time (HH:mm)	Time segment length (min)	Run automatically
D1	Base	AM	J3 Otterpool Park AM PEAK	ONE HOUR	07:45	09:15	15	9

Vehicle mix varies over turn	Vehicle mix varies over entry	Vehicle mix source	PCU Factor for a HV (PCU)
9	9	HV Percentages	2.00

Demand overview (Traffic)

Arm	Linked arm	Profile type	Use O-D data	Average Demand (Veh/hr)	Scaling Factor (%)
A		ONE HOUR	9	314	100.000
B		ONE HOUR	9	7	100.000
C		ONE HOUR	9	290	100.000
D		ONE HOUR	9	144	100.000

Origin -Destination Data

Demand (Veh/hr)

From	To				
	\$	%	&	'	
	0	0	290	24	
	2	0	5	0	
	214	2	0	74	
	42	0	102	0	

Vehicle Mix

Heavy Vehicle Percentages

From	To				
	\$	%	&	'	
	0	0	6	0	
	0	0	0	0	
	7	0	0	3	
	7	0	2	0	

Results

Results Summary for whole modelled period

Stream	Max RFC	Max delay (s)	Max Queue (Veh)	Max LOS	Average Demand (Veh/hr)	Total Junction Arrivals (Veh)
B-ACD	0.02	8.16	0.0	A	6	10
A-BCD	0.05	6.54	0.1	A	22	34
A-B					0	0
A-C					266	399
D-ABC	0.40	14.83	0.6	B	132	198
C-ABD	0.00	6.52	0.0	A	2	3
C-D					68	102
C-A					196	295

Main Results for each time segment

07:45 - 08:00

Stream	Total Demand (Veh/hr)	Junction Arrivals (Veh)	Capacity (Veh/hr)	RFC	Throughput (Veh/hr)	Start queue (Veh)	End queue (Veh)	Delay (s)	LOS
B-ACD	5	1	482	0.011	5	0.0	0.0	7.549	A
A-BCD	18	5	595	0.031	18	0.0	0.0	6.243	A
A-B	0	0			0				
A-C	218	55			218				
D-ABC	108	27	436	0.249	107	0.0	0.3	10.913	B
C-ABD	2	0.38	582	0.003	1	0.0	0.0	6.196	A
C-D	56	14			56				
C-A	161	40			161				

08:00 - 08:15

Stream	Total Demand (Veh/hr)	Junction Arrivals (Veh)	Capacity (Veh/hr)	RFC	Throughput (Veh/hr)	Start queue (Veh)	End queue (Veh)	Delay (s)	LOS
B-ACD	6	2	468	0.013	6	0.0	0.0	7.794	A
A-BCD	22	5	587	0.037	22	0.0	0.0	6.371	A
A-B	0	0			0				
A-C	260	65			260				
D-ABC	129	32	421	0.307	129	0.3	0.4	12.298	B
C-ABD	2	0.45	571	0.003	2	0.0	0.0	6.327	A
C-D	67	17			67				
C-A	192	48			192				

08:15 - 08:30

Stream	Total Demand (Veh/hr)	Junction Arrivals (Veh)	Capacity (Veh/hr)	RFC	Throughput (Veh/hr)	Start queue (Veh)	End queue (Veh)	Delay (s)	LOS
B-ACD	8	2	449	0.017	8	0.0	0.0	8.162	A
A-BCD	27	7	577	0.047	27	0.0	0.1	6.543	A
A-B	0	0			0				
A-C	319	80			319				
D-ABC	159	40	401	0.395	158	0.4	0.6	14.733	B
C-ABD	2	0.55	555	0.004	2	0.0	0.0	6.516	A
C-D	81	20			81				
C-A	236	59			236				

08:30 - 08:45

Stream	Total Demand (Veh/hr)	Junction Arrivals (Veh)	Capacity (Veh/hr)	RFC	Throughput (Veh/hr)	Start queue (Veh)	End queue (Veh)	Delay (s)	LOS
B-ACD	8	2	449	0.017	8	0.0	0.0	8.163	A
A-BCD	27	7	577	0.047	27	0.1	0.1	6.543	A
A-B	0	0			0				
A-C	319	80			319				
D-ABC	159	40	401	0.395	159	0.6	0.6	14.826	B
C-ABD	2	0.55	555	0.004	2	0.0	0.0	6.517	A
C-D	81	20			81				
C-A	236	59			236				

08:45 - 09:00

Stream	Total Demand (Veh/hr)	Junction Arrivals (Veh)	Capacity (Veh/hr)	RFC	Throughput (Veh/hr)	Start queue (Veh)	End queue (Veh)	Delay (s)	LOS
B-ACD	6	2	468	0.013	6	0.0	0.0	7.797	A
A-BCD	22	5	587	0.037	22	0.1	0.0	6.372	A
A-B	0	0			0				
A-C	260	65			260				
D-ABC	129	32	421	0.307	130	0.6	0.5	12.403	B
C-ABD	2	0.45	571	0.003	2	0.0	0.0	6.328	A
C-D	67	17			67				
C-A	192	48			192				

09:00 - 09:15

Stream	Total Demand (Veh/hr)	Junction Arrivals (Veh)	Capacity (Veh/hr)	RFC	Throughput (Veh/hr)	Start queue (Veh)	End queue (Veh)	Delay (s)	LOS
B-ACD	5	1	482	0.011	5	0.0	0.0	7.554	A
A-BCD	18	5	595	0.031	18	0.0	0.0	6.248	A
A-B	0	0			0				
A-C	218	55			218				
D-ABC	108	27	436	0.249	109	0.5	0.3	11.030	B
C-ABD	2	0.38	582	0.003	2	0.0	0.0	6.199	A
C-D	56	14			56				
C-A	161	40			161				

Base, PM

Data Errors and Warnings

No errors or warnings

Junction Network

Junctions

Junction	Name	Junction Type	Major road direction	Junction Delay (s)	Junction LOS
1	untitled	Crossroads	Two-way	2.22	A

Junction Network Options

Driving side	Lighting
Left	Normal/unknown

Traffic Demand

Demand Set Details

ID	Scenario name	Time Period name	Description	Traffic profile type	Start time (HH:mm)	Finish time (HH:mm)	Time segment length (min)	Run automatically
D2	Base	PM	J3 Otterpool Park PM PEAK	ONE HOUR	16:45	18:15	15	9

Vehicle mix varies over turn	Vehicle mix varies over entry	Vehicle mix source	PCU Factor for a HV (PCU)
9	9	HV Percentages	2.00

Demand overview (Traffic)

Arm	Linked arm	Profile type	Use O-D data	Average Demand (Veh/hr)	Scaling Factor (%)
A		ONE HOUR	9	271	100.000
B		ONE HOUR	9	2	100.000
C		ONE HOUR	9	412	100.000
D		ONE HOUR	9	105	100.000

Origin -Destination Data

Demand (Veh/hr)

		To				
		\$	%	&	'	
From	\$	0	2	211	58	
	%	1	0	1	0	
	&	278	3	0	131	
	'	34	0	71	0	

Vehicle Mix

Heavy Vehicle Percentages

		To				
		\$	%	&	'	
From	\$	0	0	2	0	
	%	0	0	100	0	
	&	4	0	0	1	
	'	0	0	0	0	

Results

Results Summary for whole modelled period

Stream	Max RFC	Max delay (s)	Max Queue (Veh)	Max LOS	Average Demand (Veh/hr)	Total Junction Arrivals (Veh)
B-ACD	0.00	0.00	0.0	A	0	0
A-BCD	0.12	7.32	0.1	A	55	83
A-B					2	3
A-C					192	287
D-ABC	0.29	12.62	0.4	B	96	145
C-ABD	0.01	6.39	0.0	A	3	4
C-D					120	180
C-A					255	383

Main Results for each time segment

16:45 - 17:00

Stream	Total Demand (Veh/hr)	Junction Arrivals (Veh)	Capacity (Veh/hr)	RFC	Throughput (Veh/hr)	Start queue (Veh)	End queue (Veh)	Delay (s)	LOS
B-ACD	0	0	332	0.000	0	0.0	0.0	0.000	A
A-BCD	45	11	579	0.077	44	0.0	0.1	6.727	A
A-B	1	0.37			1				
A-C	158	39			158				
D-ABC	79	20	442	0.179	78	0.0	0.2	9.871	A
C-ABD	2	0.57	591	0.004	2	0.0	0.0	6.119	A
C-D	99	25			99				
C-A	209	52			209				

17:00 - 17:15

Stream	Total Demand (Veh/hr)	Junction Arrivals (Veh)	Capacity (Veh/hr)	RFC	Throughput (Veh/hr)	Start queue (Veh)	End queue (Veh)	Delay (s)	LOS
B-ACD	0	0	319	0.000	0	0.0	0.0	0.000	A
A-BCD	54	13	570	0.095	54	0.1	0.1	6.975	A
A-B	2	0.45			2				
A-C	188	47			188				
D-ABC	94	24	425	0.222	94	0.2	0.3	10.876	B
C-ABD	3	0.68	580	0.005	3	0.0	0.0	6.230	A
C-D	118	29			118				
C-A	250	62			250				

17:15 - 17:30

Stream	Total Demand (Veh/hr)	Junction Arrivals (Veh)	Capacity (Veh/hr)	RFC	Throughput (Veh/hr)	Start queue (Veh)	End queue (Veh)	Delay (s)	LOS
B-ACD	0	0	302	0.000	0	0.0	0.0	0.000	A
A-BCD	67	17	559	0.120	67	0.1	0.1	7.311	A
A-B	2	0.54			2				
A-C	229	57			229				
D-ABC	116	29	401	0.288	115	0.3	0.4	12.575	B
C-ABD	3	0.83	567	0.006	3	0.0	0.0	6.388	A
C-D	144	36			144				
C-A	306	77			306				

17:30 - 17:45

Stream	Total Demand (Veh/hr)	Junction Arrivals (Veh)	Capacity (Veh/hr)	RFC	Throughput (Veh/hr)	Start queue (Veh)	End queue (Veh)	Delay (s)	LOS
B-ACD	0	0	302	0.000	0	0.0	0.0	0.000	A
A-BCD	67	17	559	0.120	67	0.1	0.1	7.317	A
A-B	2	0.54			2				
A-C	229	57			229				
D-ABC	116	29	401	0.288	116	0.4	0.4	12.616	B
C-ABD	3	0.83	567	0.006	3	0.0	0.0	6.388	A
C-D	144	36			144				
C-A	306	77			306				

17:45 - 18:00

Stream	Total Demand (Veh/hr)	Junction Arrivals (Veh)	Capacity (Veh/hr)	RFC	Throughput (Veh/hr)	Start queue (Veh)	End queue (Veh)	Delay (s)	LOS
B-ACD	0	0	319	0.000	0	0.0	0.0	0.000	A
A-BCD	54	13	570	0.094	54	0.1	0.1	6.979	A
A-B	2	0.45			2				
A-C	188	47			188				
D-ABC	94	24	425	0.222	95	0.4	0.3	10.927	B
C-ABD	3	0.68	580	0.005	3	0.0	0.0	6.231	A
C-D	118	29			118				
C-A	250	62			250				

18:00 - 18:15

Stream	Total Demand (Veh/hr)	Junction Arrivals (Veh)	Capacity (Veh/hr)	RFC	Throughput (Veh/hr)	Start queue (Veh)	End queue (Veh)	Delay (s)	LOS
B-ACD	0	0	332	0.000	0	0.0	0.0	0.000	A
A-BCD	45	11	579	0.077	45	0.1	0.1	6.738	A
A-B	1	0.37			1				
A-C	158	39			158				
D-ABC	79	20	442	0.179	79	0.3	0.2	9.936	A
C-ABD	2	0.57	590	0.004	2	0.0	0.0	6.123	A
C-D	99	25			99				
C-A	209	52			209				

F.4 J4_A20 Ashford Rd Stone Hill

Junctions 9
PICADY 9 - Priority Intersection Module
Version: 9.0.2.5947 © Copyright TRL Limited, 2017
For sales and distribution information, program advice and maintenance, contact TRL: +44 (0)1344 770558 software@trl.co.uk www.trlsoftware.co.uk
The users of this computer program for the solution of an engineering problem are in no way relieved of their responsibility for the correctness of the solution

Filename: J4_A20 Ashford Rd Stone Hill_Base Model.j9

Path: K:\UA008926 Otterpool\D-Calcs\Modelling\DM_it5\Appendix\Appendix Base Models\Picady\J4 A20 Ashford Rd - Stone Hill

Report generation date: 20/11/2018 15:37:04

»Base, AM

»Base, PM

Summary of junction performance

	AM				PM			
	Queue (Veh)	Delay (s)	RFC	LOS	Queue (Veh)	Delay (s)	RFC	LOS
	Base							
Stream B-AC	0.3	12.17	0.24	B	0.2	11.26	0.14	B
Stream C-AB	0.0	7.01	0.00	A	0.0	6.78	0.01	A

Values shown are the highest values encountered over all time segments. Delay is the maximum value of average delay per arriving vehicle.

File summary

File Description

Title	J4 Otterpool Park_Base Model
Location	A20 Ashford Road - Stone Hill
Site number	
Date	10/07/2017
Version	
Status	Draft 1
Identifier	
Client	
Jobnumber	
Enumerator	dma78191 [C8Z9W0G2]
Description	

Units

Distance units	Speed units	Traffic units input	Traffic units results	Flow units	Average delay units	Total delay units	Rate of delay units
m	kph	Veh	Veh	perHour	s	-Hour	perHour

Analysis Options

Vehicle length (m)	Calculate Queue Percentiles	Calculate detailed queueing delay	Calculate residual capacity	RFC Threshold	Average Delay threshold (s)	Queue threshold (PCU)
5.75				0.85	36.00	20.00

Demand Set Summary

ID	Scenario name	Time Period name	Description	Traffic profile type	Start time (HH:mm)	Finish time (HH:mm)	Time segment length (min)	Run automatically
D1	Base	AM	J4 Otterpool Park AM PEAK	ONE HOUR	07:45	09:15	15	9
D2	Base	PM	J4 Otterpool Park PM PEAK	ONE HOUR	16:45	18:15	15	9

Analysis Set Details

ID	Include in report	Network flow scaling factor (%)	Network capacity scaling factor (%)
A1	9	100.000	100.000

Base, AM

Data Errors and Warnings

No errors or warnings

Junction Network

Junctions

Junction	Name	Junction Type	Major road direction	Junction Delay (s)	Junction LOS
1	untitled	T-Junction	Two-way	1.49	A

Junction Network Options

Driving side	Lighting
Left	Normal/unknown

Arms

Arms

Arm	Name	Description	Arm type
A	A20 Ashford Road Westbound		Major
B	Stone Hill		Minor
C	A20 Ashford Road Eastbound		Major

Major Arm Geometry

Arm	Width of carriageway (m)	Has kerbed central reserve	Has right turn bay	Visibility for right turn (m)	Blocks?	Blocking queue (PCU)
C	6.10			71.0	9	1.00

Geometries for Arm C are measured opposite Arm B. Geometries for Arm A (if relevant) are measured opposite Arm D.

Minor Arm Geometry

Arm	Minor arm type	Lane width (m)	Visibility to left (m)	Visibility to right (m)
B	One lane	2.60	111	19

Slope / Intercept / Capacity

Priority Intersection Slopes and Intercepts

Junction	Stream	Intercept (Veh/hr)	Slope for A-B	Slope for A-C	Slope for C-A	Slope for C-B
1	B-A	502	0.091	0.230	0.145	0.329
1	B-C	610	0.093	0.235	-	-
1	C-B	615	0.237	0.237	-	-

The slopes and intercepts shown above do NOT include any corrections or adjustments.

Streams may be combined, in which case capacity will be adjusted.

Values are shown for the first time segment only; they may differ for subsequent time segments.

Traffic Demand

Demand Set Details

ID	Scenario name	Time Period name	Description	Traffic profile type	Start time (HH:mm)	Finish time (HH:mm)	Time segment length (min)	Run automatically
D1	Base	AM	J4 Otterpool Park AM PEAK	ONE HOUR	07:45	09:15	15	9

Vehicle mix varies over turn	Vehicle mix varies over entry	Vehicle mix source	PCU Factor for a HV (PCU)
9	9	HV Percentages	2.00

Demand overview (Traffic)

Arm	Linked arm	Profile type	Use O-D data	Average Demand (Veh/hr)	Scaling Factor (%)
A		ONE HOUR	9	374	100.000
B		ONE HOUR	9	84	100.000
C		ONE HOUR	9	209	100.000

Origin -Destination Data

Demand (Veh/hr)

From	To			
	\$	%	&	
\$	0	63	311	
%	76	0	8	
&	208	1	0	

Vehicle Mix

Heavy Vehicle Percentages

From	To			
	\$	%	&	
\$	0	2	4	
%	0	0	0	
&	5	0	0	

Results

Results Summary for whole modelled period

Stream	Max RFC	Max delay (s)	Max Queue (Veh)	Max LOS	Average Demand (Veh/hr)	Total Junction Arrivals (Veh)
B-AC	0.24	12.17	0.3	B	77	116
C-AB	0.00	7.01	0.0	A	0.92	1
C-A					191	286
A-B					58	87
A-C					285	428

Main Results for each time segment

07:45 - 08:00

Stream	Total Demand (Veh/hr)	Junction Arrivals (Veh)	Capacity (Veh/hr)	RFC	Throughput (Veh/hr)	Start queue (Veh)	End queue (Veh)	Delay (s)	LOS
B-AC	63	16	427	0.148	63	0.0	0.2	9.858	A
C-AB	0.75	0.19	546	0.001	0.75	0.0	0.0	6.601	A
C-A	157	39			157				
A-B	47	12			47				
A-C	234	59			234				

08:00 - 08:15

Stream	Total Demand (Veh/hr)	Junction Arrivals (Veh)	Capacity (Veh/hr)	RFC	Throughput (Veh/hr)	Start queue (Veh)	End queue (Veh)	Delay (s)	LOS
B-AC	76	19	411	0.184	75	0.2	0.2	10.724	B
C-AB	0.90	0.22	533	0.002	0.90	0.0	0.0	6.768	A
C-A	187	47			187				
A-B	57	14			57				
A-C	280	70			280				

08:15 - 08:30

Stream	Total Demand (Veh/hr)	Junction Arrivals (Veh)	Capacity (Veh/hr)	RFC	Throughput (Veh/hr)	Start queue (Veh)	End queue (Veh)	Delay (s)	LOS
B-AC	92	23	388	0.238	92	0.2	0.3	12.136	B
C-AB	1	0.28	514	0.002	1	0.0	0.0	7.014	A
C-A	229	57			229				
A-B	69	17			69				
A-C	342	86			342				

08:30 - 08:45

Stream	Total Demand (Veh/hr)	Junction Arrivals (Veh)	Capacity (Veh/hr)	RFC	Throughput (Veh/hr)	Start queue (Veh)	End queue (Veh)	Delay (s)	LOS
B-AC	92	23	388	0.238	92	0.3	0.3	12.168	B
C-AB	1	0.28	514	0.002	1	0.0	0.0	7.014	A
C-A	229	57			229				
A-B	69	17			69				
A-C	342	86			342				

08:45 - 09:00

Stream	Total Demand (Veh/hr)	Junction Arrivals (Veh)	Capacity (Veh/hr)	RFC	Throughput (Veh/hr)	Start queue (Veh)	End queue (Veh)	Delay (s)	LOS
B-AC	76	19	411	0.184	76	0.3	0.2	10.760	B
C-AB	0.90	0.22	533	0.002	0.90	0.0	0.0	6.771	A
C-A	187	47			187				
A-B	57	14			57				
A-C	280	70			280				

09:00 - 09:15

Stream	Total Demand (Veh/hr)	Junction Arrivals (Veh)	Capacity (Veh/hr)	RFC	Throughput (Veh/hr)	Start queue (Veh)	End queue (Veh)	Delay (s)	LOS
B-AC	63	16	427	0.148	63	0.2	0.2	9.907	A
C-AB	0.75	0.19	546	0.001	0.75	0.0	0.0	6.601	A
C-A	157	39			157				
A-B	47	12			47				
A-C	234	59			234				

Base, PM

Data Errors and Warnings

No errors or warnings

Junction Network

Junctions

Junction	Name	Junction Type	Major road direction	Junction Delay (s)	Junction LOS
1	untitled	T-Junction	Two-way	0.76	A

Junction Network Options

Driving side	Lighting
Left	Normal/unknown

Traffic Demand

Demand Set Details

ID	Scenario name	Time Period name	Description	Traffic profile type	Start time (HH:mm)	Finish time (HH:mm)	Time segment length (min)	Run automatically
D2	Base	PM	J4 Otterpool Park PM PEAK	ONE HOUR	16:45	18:15	15	9

Vehicle mix varies over turn	Vehicle mix varies over entry	Vehicle mix source	PCU Factor for a HV (PCU)
9	9	HV Percentages	2.00

Demand overview (Traffic)

Arm	Linked arm	Profile type	Use O-D data	Average Demand (Veh/hr)	Scaling Factor (%)
A		ONE HOUR	9	315	100.000
B		ONE HOUR	9	49	100.000
C		ONE HOUR	9	391	100.000

Origin -Destination Data

Demand (Veh/hr)

		To			
		\$	%	&	
From	\$	0	51	264	
	%	45	0	4	
	&	386	5	0	

Vehicle Mix

Heavy Vehicle Percentages

		To			
		\$	%	&	
From	\$	0	2	1	
	%	0	0	0	
	&	3	0	0	

Results

Results Summary for whole modelled period

Stream	Max RFC	Max delay (s)	Max Queue (Veh)	Max LOS	Average Demand (Veh/hr)	Total Junction Arrivals (Veh)
B-AC	0.14	11.26	0.2	B	45	67
C-AB	0.01	6.78	0.0	A	5	7
C-A					354	531
A-B					47	70
A-C					242	363

Main Results for each time segment

16:45 - 17:00

Stream	Total Demand (Veh/hr)	Junction Arrivals (Veh)	Capacity (Veh/hr)	RFC	Throughput (Veh/hr)	Start queue (Veh)	End queue (Veh)	Delay (s)	LOS
B-AC	37	9	417	0.089	37	0.0	0.1	9.459	A
C-AB	4	0.94	560	0.007	4	0.0	0.0	6.470	A
C-A	291	73			291				
A-B	38	10			38				
A-C	199	50			199				

17:00 - 17:15

Stream	Total Demand (Veh/hr)	Junction Arrivals (Veh)	Capacity (Veh/hr)	RFC	Throughput (Veh/hr)	Start queue (Veh)	End queue (Veh)	Delay (s)	LOS
B-AC	44	11	399	0.111	44	0.1	0.1	10.145	B
C-AB	5	1	550	0.008	5	0.0	0.0	6.599	A
C-A	347	87			347				
A-B	46	11			46				
A-C	237	59			237				

17:15 - 17:30

Stream	Total Demand (Veh/hr)	Junction Arrivals (Veh)	Capacity (Veh/hr)	RFC	Throughput (Veh/hr)	Start queue (Veh)	End queue (Veh)	Delay (s)	LOS
B-AC	54	13	374	0.144	54	0.1	0.2	11.249	B
C-AB	6	1	536	0.010	6	0.0	0.0	6.782	A
C-A	425	106			425				
A-B	56	14			56				
A-C	291	73			291				

17:30 - 17:45

Stream	Total Demand (Veh/hr)	Junction Arrivals (Veh)	Capacity (Veh/hr)	RFC	Throughput (Veh/hr)	Start queue (Veh)	End queue (Veh)	Delay (s)	LOS
B-AC	54	13	374	0.144	54	0.2	0.2	11.260	B
C-AB	6	1	536	0.010	6	0.0	0.0	6.782	A
C-A	425	106			425				
A-B	56	14			56				
A-C	291	73			291				

17:45 - 18:00

Stream	Total Demand (Veh/hr)	Junction Arrivals (Veh)	Capacity (Veh/hr)	RFC	Throughput (Veh/hr)	Start queue (Veh)	End queue (Veh)	Delay (s)	LOS
B-AC	44	11	399	0.111	44	0.2	0.1	10.163	B
C-AB	5	1	550	0.008	5	0.0	0.0	6.599	A
C-A	347	87			347				
A-B	46	11			46				
A-C	237	59			237				

18:00 - 18:15

Stream	Total Demand (Veh/hr)	Junction Arrivals (Veh)	Capacity (Veh/hr)	RFC	Throughput (Veh/hr)	Start queue (Veh)	End queue (Veh)	Delay (s)	LOS
B-AC	37	9	417	0.089	37	0.1	0.1	9.483	A
C-AB	4	0.94	560	0.007	4	0.0	0.0	6.470	A
C-A	291	73			291				
A-B	38	10			38				
A-C	199	50			199				

F.5 J5_A20 Station Rd Church Rd

<h1>Junctions 9</h1>
<h2>PICADY 9 - Priority Intersection Module</h2>
Version: 9.0.2.5947 © Copyright TRL Limited, 2017
For sales and distribution information, program advice and maintenance, contact TRL: +44 (0)1344 770558 software@trl.co.uk www.trlsoftware.co.uk
The users of this computer program for the solution of an engineering problem are in no way relieved of their responsibility for the correctness of the solution

Filename: J5_A20 Station Rd Church Rd_Base Model.j9

Path: K:\UA008926 Otterpool\D-Calcs\Modelling\DM_it5\Appendix\Appendix Base Models\Picady\J5 A20-Station Rd-Church Rd

Report generation date: 20/11/2018 15:38:00

»Base, AM

»Base, PM

Summary of junction performance

	AM				PM			
	Queue (Veh)	Delay (s)	RFC	LOS	Queue (Veh)	Delay (s)	RFC	LOS
	Base							
Stream B-ACD	0.6	12.95	0.36	B	0.7	14.34	0.42	B
Stream A-BCD	0.0	5.78	0.02	A	0.0	6.31	0.03	A
Stream D-ABC	0.5	15.24	0.33	C	0.3	14.82	0.22	B
Stream C-ABD	0.2	6.54	0.18	A	0.2	6.29	0.16	A

Values shown are the highest values encountered over all time segments. Delay is the maximum value of average delay per arriving vehicle.

File summary

File Description

Title	J5 Otterpool Park Base Model
Location	A20 Hythe Road / Station Road / Church Road
Site number	
Date	14/06/2017
Version	
Status	Draft 1
Identifier	
Client	
Jobnumber	
Enumerator	dma78191 [C8Z9W0G2]
Description	

Units

Distance units	Speed units	Traffic units input	Traffic units results	Flow units	Average delay units	Total delay units	Rate of delay units
m	kph	Veh	Veh	perHour	s	-Hour	perHour

Analysis Options

Vehicle length (m)	Calculate Queue Percentiles	Calculate detailed queueing delay	Calculate residual capacity	RFC Threshold	Average Delay threshold (s)	Queue threshold (PCU)
5.75				0.85	36.00	20.00

Demand Set Summary

ID	Scenario name	Time Period name	Description	Traffic profile type	Start time (HH:mm)	Finish time (HH:mm)	Time segment length (min)	Run automatically
D1	Base	AM	J5 A20-Station Rd AM PEAK	ONE HOUR	07:45	09:15	15	9
D2	Base	PM	J5 A20-Station Rd PM PEAK	ONE HOUR	16:45	18:15	15	9

Analysis Set Details

ID	Include in report	Network flow scaling factor (%)	Network capacity scaling factor (%)
A1	9	100.000	100.000

Base, AM

Data Errors and Warnings

No errors or warnings

Junction Network

Junctions

Junction	Name	Junction Type	Major road direction	Junction Delay (s)	Junction LOS
1	untitled	Crossroads	Two-way	4.53	A

Junction Network Options

Driving side	Lighting
Left	Normal/unknown

Arms

Arms

Arm	Name	Description	Arm type
A	A20 Hythe Road Westbound		Major
B	Station Road		Minor
C	A20 Hythe Road Eastbound		Major
D	Church Road		Minor

Major Arm Geometry

Arm	Width of carriageway (m)	Has kerbed central reserve	Has right turn bay	Width for right turn (m)	Visibility for right turn (m)	Blocks?	Blocking queue (PCU)
A	6.70		9	3.80	150.0	9	6.00
C	6.70		9	3.80	150.0	9	6.00

Geometries for Arm C are measured opposite Arm B. Geometries for Arm A (if relevant) are measured opposite Arm D.

Minor Arm Geometry

Arm	Minor arm type	Lane width (m)	Visibility to left (m)	Visibility to right (m)
B	One lane	3.00	28	18
D	One lane	3.00	19	18

Slope / Intercept / Capacity

Priority Intersection Slopes and Intercepts

Junction	Stream	Intercept (Veh/hr)	Slope for A-B	Slope for A-C	Slope for A-D	Slope for B-A	Slope for B-C	Slope for B-D	Slope for C-A	Slope for C-B	Slope for C-D	Slope for D-A	Slope for D-B	Slope for D-C
1	A-D	776	-	-	-	-	-	-	0.291	0.416	0.291	-	-	-
1	B-A	496	0.088	0.221	0.221	-	-	-	0.139	0.316	-	0.221	0.221	0.111
1	B-C	635	0.094	0.239	-	-	-	-	-	-	-	-	-	-
1	B-D, nearside lane	496	0.088	0.221	0.221	-	-	-	0.139	0.316	0.139	-	-	-
1	B-D, offside lane	496	0.088	0.221	0.221	-	-	-	0.139	0.316	0.139	-	-	-
1	C-B	776	0.291	0.291	0.416	-	-	-	-	-	-	-	-	-
1	D-A	635	-	-	-	-	-	-	0.239	-	0.094	-	-	-
1	D-B, nearside lane	493	0.138	0.138	0.314	-	-	-	0.220	0.220	0.087	-	-	-
1	D-B, offside lane	493	0.138	0.138	0.314	-	-	-	0.220	0.220	0.087	-	-	-
1	D-C	493	-	0.138	0.314	0.110	0.220	0.220	0.220	0.220	0.087	-	-	-

The slopes and intercepts shown above do NOT include any corrections or adjustments.

Streams may be combined, in which case capacity will be adjusted.
 Values are shown for the first time segment only; they may differ for subsequent time segments.

Traffic Demand

Demand Set Details

ID	Scenario name	Time Period name	Description	Traffic profile type	Start time (HH:mm)	Finish time (HH:mm)	Time segment length (min)	Run automatically
D1	Base	AM	J5 A20-Station Rd AM PEAK	ONE HOUR	07:45	09:15	15	9

Vehicle mix varies over turn	Vehicle mix varies over entry	Vehicle mix source	PCU Factor for a HV (PCU)
9	9	HV Percentages	2.00

Demand overview (Traffic)

Arm	Linked arm	Profile type	Use O-D data	Average Demand (Veh/hr)	Scaling Factor (%)
A		ONE HOUR	9	297	100.000
B		ONE HOUR	9	145	100.000
C		ONE HOUR	9	380	100.000
D		ONE HOUR	9	107	100.000

Origin -Destination Data

Demand (Veh/hr)

From	To				
	\$	%	&	'	
	0	47	241	9	
	26	0	94	25	
	199	108	0	73	
	14	20	73	0	

Vehicle Mix

Heavy Vehicle Percentages

From	To				
	\$	%	&	'	
	0	4	4	0	
	8	0	4	4	
	7	1	0	3	
	0	0	1	0	

Results

Results Summary for whole modelled period

Stream	Max RFC	Max delay (s)	Max Queue (Veh)	Max LOS	Average Demand (Veh/hr)	Total Junction Arrivals (Veh)
B-ACD	0.36	12.95	0.6	B	133	200
A-BCD	0.02	5.78	0.0	A	8	12
A-B					43	65
A-C					221	332
D-ABC	0.33	15.24	0.5	C	98	147
C-ABD	0.18	6.54	0.2	A	99	149
C-D					67	100
C-A					183	274

Main Results for each time segment

07:45 - 08:00

Stream	Total Demand (Veh/hr)	Junction Arrivals (Veh)	Capacity (Veh/hr)	RFC	Throughput (Veh/hr)	Start queue (Veh)	End queue (Veh)	Delay (s)	LOS
B-ACD	109	27	475	0.230	108	0.0	0.3	9.765	A
A-BCD	7	2	678	0.010	7	0.0	0.0	5.358	A
A-B	35	9			35				
A-C	181	45			181				
D-ABC	81	20	402	0.200	80	0.0	0.2	11.116	B
C-ABD	81	20	700	0.116	81	0.0	0.1	5.805	A
C-D	55	14			55				
C-A	150	37			150				

08:00 - 08:15

Stream	Total Demand (Veh/hr)	Junction Arrivals (Veh)	Capacity (Veh/hr)	RFC	Throughput (Veh/hr)	Start queue (Veh)	End queue (Veh)	Delay (s)	LOS
B-ACD	130	33	460	0.284	130	0.3	0.4	10.901	B
A-BCD	8	2	659	0.012	8	0.0	0.0	5.527	A
A-B	42	11			42				
A-C	217	54			217				
D-ABC	96	24	382	0.252	96	0.2	0.3	12.559	B
C-ABD	97	24	687	0.141	97	0.1	0.2	6.097	A
C-D	66	16			66				
C-A	179	45			179				

08:15 - 08:30

Stream	Total Demand (Veh/hr)	Junction Arrivals (Veh)	Capacity (Veh/hr)	RFC	Throughput (Veh/hr)	Start queue (Veh)	End queue (Veh)	Delay (s)	LOS
B-ACD	160	40	438	0.365	159	0.4	0.6	12.883	B
A-BCD	10	2	633	0.016	10	0.0	0.0	5.775	A
A-B	52	13			52				
A-C	265	66			265				
D-ABC	118	29	354	0.333	117	0.3	0.5	15.150	C
C-ABD	119	30	669	0.178	119	0.2	0.2	6.541	A
C-D	80	20			80				
C-A	219	55			219				

08:30 - 08:45

Stream	Total Demand (Veh/hr)	Junction Arrivals (Veh)	Capacity (Veh/hr)	RFC	Throughput (Veh/hr)	Start queue (Veh)	End queue (Veh)	Delay (s)	LOS
B-ACD	160	40	438	0.365	160	0.6	0.6	12.947	B
A-BCD	10	2	633	0.016	10	0.0	0.0	5.776	A
A-B	52	13			52				
A-C	265	66			265				
D-ABC	118	29	354	0.333	118	0.5	0.5	15.239	C
C-ABD	119	30	669	0.178	119	0.2	0.2	6.544	A
C-D	80	20			80				
C-A	219	55			219				

08:45 - 09:00

Stream	Total Demand (Veh/hr)	Junction Arrivals (Veh)	Capacity (Veh/hr)	RFC	Throughput (Veh/hr)	Start queue (Veh)	End queue (Veh)	Delay (s)	LOS
B-ACD	130	33	460	0.284	131	0.6	0.4	10.975	B
A-BCD	8	2	659	0.012	8	0.0	0.0	5.530	A
A-B	42	11			42				
A-C	217	54			217				
D-ABC	96	24	382	0.252	97	0.5	0.3	12.653	B
C-ABD	97	24	687	0.141	97	0.2	0.2	6.104	A
C-D	66	16			66				
C-A	179	45			179				

09:00 - 09:15

Stream	Total Demand (Veh/hr)	Junction Arrivals (Veh)	Capacity (Veh/hr)	RFC	Throughput (Veh/hr)	Start queue (Veh)	End queue (Veh)	Delay (s)	LOS
B-ACD	109	27	475	0.230	110	0.4	0.3	9.855	A
A-BCD	7	2	678	0.010	7	0.0	0.0	5.361	A
A-B	35	9			35				
A-C	181	45			181				
D-ABC	81	20	402	0.200	81	0.3	0.3	11.223	B
C-ABD	81	20	700	0.116	81	0.2	0.1	5.817	A
C-D	55	14			55				
C-A	150	37			150				

Base, PM

Data Errors and Warnings

No errors or warnings

Junction Network

Junctions

Junction	Name	Junction Type	Major road direction	Junction Delay (s)	Junction LOS
1	untitled	Crossroads	Two-way	3.81	A

Junction Network Options

Driving side	Lighting
Left	Normal/unknown

Traffic Demand

Demand Set Details

ID	Scenario name	Time Period name	Description	Traffic profile type	Start time (HH:mm)	Finish time (HH:mm)	Time segment length (min)	Run automatically
D2	Base	PM	J5 A20-Station Rd PM PEAK	ONE HOUR	16:45	18:15	15	9

Vehicle mix varies over turn	Vehicle mix varies over entry	Vehicle mix source	PCU Factor for a HV (PCU)
9	9	HV Percentages	2.00

Demand overview (Traffic)

Arm	Linked arm	Profile type	Use O-D data	Average Demand (Veh/hr)	Scaling Factor (%)
A		ONE HOUR	9	294	100.000
B		ONE HOUR	9	162	100.000
C		ONE HOUR	9	526	100.000
D		ONE HOUR	9	63	100.000

Origin -Destination Data

Demand (Veh/hr)

		To				
		\$	%	&	'	
From	\$	0	40	236	18	
	%	36	0	94	32	
	&	329	96	0	101	
	'	7	15	41	0	

Vehicle Mix

Heavy Vehicle Percentages

		To				
		\$	%	&	'	
From	\$	0	0	1	0	
	%	0	0	2	3	
	&	3	0	0	0	
	'	0	13	0	0	

Results

Results Summary for whole modelled period

Stream	Max RFC	Max delay (s)	Max Queue (Veh)	Max LOS	Average Demand (Veh/hr)	Total Junction Arrivals (Veh)
B-ACD	0.42	14.34	0.7	B	149	223
A-BCD	0.03	6.31	0.0	A	17	25
A-B					37	55
A-C					217	325
D-ABC	0.22	14.82	0.3	B	58	87
C-ABD	0.16	6.29	0.2	A	88	132
C-D					93	139
C-A					302	453

Main Results for each time segment

16:45 - 17:00

Stream	Total Demand (Veh/hr)	Junction Arrivals (Veh)	Capacity (Veh/hr)	RFC	Throughput (Veh/hr)	Start queue (Veh)	End queue (Veh)	Delay (s)	LOS
B-ACD	122	30	473	0.258	121	0.0	0.3	10.185	B
A-BCD	14	3	649	0.021	13	0.0	0.0	5.662	A
A-B	30	8			30				
A-C	178	44			178				
D-ABC	47	12	369	0.128	47	0.0	0.1	11.141	B
C-ABD	72	18	709	0.102	72	0.0	0.1	5.645	A
C-D	76	19			76				
C-A	248	62			248				

17:00 - 17:15

Stream	Total Demand (Veh/hr)	Junction Arrivals (Veh)	Capacity (Veh/hr)	RFC	Throughput (Veh/hr)	Start queue (Veh)	End queue (Veh)	Delay (s)	LOS
B-ACD	146	36	455	0.320	145	0.3	0.5	11.606	B
A-BCD	16	4	625	0.026	16	0.0	0.0	5.917	A
A-B	36	9			36				
A-C	212	53			212				
D-ABC	57	14	345	0.164	56	0.1	0.2	12.450	B
C-ABD	86	22	696	0.124	86	0.1	0.1	5.902	A
C-D	91	23			91				
C-A	296	74			296				

17:15 - 17:30

Stream	Total Demand (Veh/hr)	Junction Arrivals (Veh)	Capacity (Veh/hr)	RFC	Throughput (Veh/hr)	Start queue (Veh)	End queue (Veh)	Delay (s)	LOS
B-ACD	178	45	429	0.415	177	0.5	0.7	14.232	B
A-BCD	20	5	590	0.034	20	0.0	0.0	6.307	A
A-B	44	11			44				
A-C	260	65			260				
D-ABC	69	17	312	0.222	69	0.2	0.3	14.774	B
C-ABD	106	26	678	0.156	106	0.1	0.2	6.284	A
C-D	111	28			111				
C-A	362	91			362				

17:30 - 17:45

Stream	Total Demand (Veh/hr)	Junction Arrivals (Veh)	Capacity (Veh/hr)	RFC	Throughput (Veh/hr)	Start queue (Veh)	End queue (Veh)	Delay (s)	LOS
B-ACD	178	45	429	0.415	178	0.7	0.7	14.336	B
A-BCD	20	5	590	0.034	20	0.0	0.0	6.308	A
A-B	44	11			44				
A-C	260	65			260				
D-ABC	69	17	312	0.222	69	0.3	0.3	14.825	B
C-ABD	106	26	678	0.156	106	0.2	0.2	6.286	A
C-D	111	28			111				
C-A	362	91			362				

17:45 - 18:00

Stream	Total Demand (Veh/hr)	Junction Arrivals (Veh)	Capacity (Veh/hr)	RFC	Throughput (Veh/hr)	Start queue (Veh)	End queue (Veh)	Delay (s)	LOS
B-ACD	146	36	455	0.320	147	0.7	0.5	11.714	B
A-BCD	16	4	624	0.026	16	0.0	0.0	5.921	A
A-B	36	9			36				
A-C	212	53			212				
D-ABC	57	14	345	0.164	57	0.3	0.2	12.506	B
C-ABD	86	22	696	0.124	86	0.2	0.1	5.907	A
C-D	91	23			91				
C-A	296	74			296				

18:00 - 18:15

Stream	Total Demand (Veh/hr)	Junction Arrivals (Veh)	Capacity (Veh/hr)	RFC	Throughput (Veh/hr)	Start queue (Veh)	End queue (Veh)	Delay (s)	LOS
B-ACD	122	30	473	0.258	122	0.5	0.4	10.298	B
A-BCD	14	3	649	0.021	14	0.0	0.0	5.666	A
A-B	30	8			30				
A-C	178	44			178				
D-ABC	47	12	369	0.129	48	0.2	0.1	11.210	B
C-ABD	72	18	709	0.102	72	0.1	0.1	5.654	A
C-D	76	19			76				
C-A	248	62			248				

F.6 J6_A20 Mersham

Junctions 9
PICADY 9 - Priority Intersection Module
Version: 9.0.2.5947 © Copyright TRL Limited, 2017
For sales and distribution information, program advice and maintenance, contact TRL: +44 (0)1344 770558 software@trl.co.uk www.trlsoftware.co.uk
The users of this computer program for the solution of an engineering problem are in no way relieved of their responsibility for the correctness of the solution

Filename: J6_A20 Mersham_Base Model.j9
Path: K:\UA008926 Otterpool\D-Calcs\Modelling\DM_it5\Appendix\Appendix Base Models\Picady\J6 A20-Mersham
Report generation date: 20/11/2018 15:39:02

- »Base, AM
- »Base, PM

Summary of junction performance

	AM				PM			
	Queue (Veh)	Delay (s)	RFC	LOS	Queue (Veh)	Delay (s)	RFC	LOS
	Base							
Stream B-AC	0.4	11.59	0.31	B	0.2	9.75	0.20	A
Stream C-AB	0.2	8.25	0.19	A	0.2	7.56	0.18	A

Values shown are the highest values encountered over all time segments. Delay is the maximum value of average delay per arriving vehicle.

File summary

File Description

Title	J6 Otterpool Park_Base Model
Location	A20 Hythe Road - Mersham
Site number	
Date	19/06/2017
Version	
Status	Draft 1
Identifier	
Client	
Jobnumber	
Enumerator	dma78191 [C8Z9W0G2]
Description	

Units

Distance units	Speed units	Traffic units input	Traffic units results	Flow units	Average delay units	Total delay units	Rate of delay units
m	kph	Veh	Veh	perHour	s	-Hour	perHour

Analysis Options

Vehicle length (m)	Calculate Queue Percentiles	Calculate detailed queueing delay	Calculate residual capacity	RFC Threshold	Average Delay threshold (s)	Queue threshold (PCU)
5.75				0.85	36.00	20.00

Demand Set Summary

ID	Scenario name	Time Period name	Description	Traffic profile type	Start time (HH:mm)	Finish time (HH:mm)	Time segment length (min)	Run automatically
D1	Base	AM	J6 A20-Mersham AM Peak	ONE HOUR	07:45	09:15	15	9
D2	Base	PM	J6 A20-Mersham PM Peak	ONE HOUR	16:45	18:15	15	9

Analysis Set Details

ID	Include in report	Network flow scaling factor (%)	Network capacity scaling factor (%)
A1	9	100.000	100.000

Base, AM

Data Errors and Warnings

No errors or warnings

Junction Network

Junctions

Junction	Name	Junction Type	Major road direction	Junction Delay (s)	Junction LOS
1	untitled	T-Junction	Two-way	1.93	A

Junction Network Options

Driving side	Lighting
Left	Normal/unknown

Arms

Arms

Arm	Name	Description	Arm type
A	A20 Hythe Road Westbound		Major
B	Mersham		Minor
C	A20 Hythe Road Eastbound		Major

Major Arm Geometry

Arm	Width of carriageway (m)	Has kerbed central reserve	Has right turn bay	Width for right turn (m)	Visibility for right turn (m)	Blocks?	Blocking queue (PCU)
C	8.68		9	3.00	130.0	9	9.00

Geometries for Arm C are measured opposite Arm B. Geometries for Arm A (if relevant) are measured opposite Arm D.

Minor Arm Geometry

Arm	Minor arm type	Lane width (m)	Visibility to left (m)	Visibility to right (m)
B	One lane	2.86	62	64

Slope / Intercept / Capacity

Priority Intersection Slopes and Intercepts

Junction	Stream	Intercept (Veh/hr)	Slope for A-B	Slope for A-C	Slope for C-A	Slope for C-B
1	B-A	522	0.084	0.212	0.134	0.303
1	B-C	655	0.089	0.224	-	-
1	C-B	706	0.242	0.242	-	-

The slopes and intercepts shown above do NOT include any corrections or adjustments.

Streams may be combined, in which case capacity will be adjusted.

Values are shown for the first time segment only; they may differ for subsequent time segments.

Traffic Demand

Demand Set Details

ID	Scenario name	Time Period name	Description	Traffic profile type	Start time (HH:mm)	Finish time (HH:mm)	Time segment length (min)	Run automatically
D1	Base	AM	J6 A20-Mersham AM Peak	ONE HOUR	07:45	09:15	15	9

Vehicle mix varies over turn	Vehicle mix varies over entry	Vehicle mix source	PCU Factor for a HV (PCU)
9	9	HV Percentages	2.00

Demand overview (Traffic)

Arm	Linked arm	Profile type	Use O-D data	Average Demand (Veh/hr)	Scaling Factor (%)
A		ONE HOUR	9	528	100.000
B		ONE HOUR	9	128	100.000
C		ONE HOUR	9	522	100.000

Origin -Destination Data

Demand (Veh/hr)

	To			
		\$	%	&
From	\$	0	24	504
	%	21	0	107
	&	428	94	0

Vehicle Mix

Heavy Vehicle Percentages

	To			
		\$	%	&
From	\$	0	0	3
	%	5	0	3
	&	3	4	0

Results

Results Summary for whole modelled period

Stream	Max RFC	Max delay (s)	Max Queue (Veh)	Max LOS	Average Demand (Veh/hr)	Total Junction Arrivals (Veh)
B-AC	0.31	11.59	0.4	B	117	176
C-AB	0.19	8.25	0.2	A	86	129
C-A					393	589
A-B					22	33
A-C					462	694

Main Results for each time segment

07:45 - 08:00

Stream	Total Demand (Veh/hr)	Junction Arrivals (Veh)	Capacity (Veh/hr)	RFC	Throughput (Veh/hr)	Start queue (Veh)	End queue (Veh)	Delay (s)	LOS
B-AC	96	24	503	0.191	95	0.0	0.2	8.804	A
C-AB	71	18	584	0.121	70	0.0	0.1	7.004	A
C-A	322	81			322				
A-B	18	5			18				
A-C	379	95			379				

08:00 - 08:15

Stream	Total Demand (Veh/hr)	Junction Arrivals (Veh)	Capacity (Veh/hr)	RFC	Throughput (Veh/hr)	Start queue (Veh)	End queue (Veh)	Delay (s)	LOS
B-AC	115	29	482	0.239	115	0.2	0.3	9.795	A
C-AB	85	21	565	0.150	84	0.1	0.2	7.484	A
C-A	385	96			385				
A-B	22	5			22				
A-C	453	113			453				

08:15 - 08:30

Stream	Total Demand (Veh/hr)	Junction Arrivals (Veh)	Capacity (Veh/hr)	RFC	Throughput (Veh/hr)	Start queue (Veh)	End queue (Veh)	Delay (s)	LOS
B-AC	141	35	452	0.312	140	0.3	0.4	11.547	B
C-AB	103	26	540	0.192	103	0.2	0.2	8.244	A
C-A	471	118			471				
A-B	26	7			26				
A-C	555	139			555				

08:30 - 08:45

Stream	Total Demand (Veh/hr)	Junction Arrivals (Veh)	Capacity (Veh/hr)	RFC	Throughput (Veh/hr)	Start queue (Veh)	End queue (Veh)	Delay (s)	LOS
B-AC	141	35	452	0.312	141	0.4	0.4	11.586	B
C-AB	103	26	540	0.192	103	0.2	0.2	8.252	A
C-A	471	118			471				
A-B	26	7			26				
A-C	555	139			555				

08:45 - 09:00

Stream	Total Demand (Veh/hr)	Junction Arrivals (Veh)	Capacity (Veh/hr)	RFC	Throughput (Veh/hr)	Start queue (Veh)	End queue (Veh)	Delay (s)	LOS
B-AC	115	29	482	0.239	116	0.4	0.3	9.839	A
C-AB	85	21	565	0.150	85	0.2	0.2	7.495	A
C-A	385	96			385				
A-B	22	5			22				
A-C	453	113			453				

09:00 - 09:15

Stream	Total Demand (Veh/hr)	Junction Arrivals (Veh)	Capacity (Veh/hr)	RFC	Throughput (Veh/hr)	Start queue (Veh)	End queue (Veh)	Delay (s)	LOS
B-AC	96	24	503	0.191	97	0.3	0.2	8.859	A
C-AB	71	18	584	0.121	71	0.2	0.1	7.022	A
C-A	322	81			322				
A-B	18	5			18				
A-C	379	95			379				

Base, PM

Data Errors and Warnings

No errors or warnings

Junction Network

Junctions

Junction	Name	Junction Type	Major road direction	Junction Delay (s)	Junction LOS
1	untitled	T-Junction	Two-way	1.28	A

Junction Network Options

Driving side	Lighting
Left	Normal/unknown

Traffic Demand

Demand Set Details

ID	Scenario name	Time Period name	Description	Traffic profile type	Start time (HH:mm)	Finish time (HH:mm)	Time segment length (min)	Run automatically
D2	Base	PM	J6 A20-Mersham PM Peak	ONE HOUR	16:45	18:15	15	9

Vehicle mix varies over turn	Vehicle mix varies over entry	Vehicle mix source	PCU Factor for a HV (PCU)
9	9	HV Percentages	2.00

Demand overview (Traffic)

Arm	Linked arm	Profile type	Use O-D data	Average Demand (Veh/hr)	Scaling Factor (%)
A		ONE HOUR	9	445	100.000
B		ONE HOUR	9	82	100.000
C		ONE HOUR	9	654	100.000

Origin -Destination Data

Demand (Veh/hr)

		To			
From		\$	%	&	
		0	23	422	
		18	0	64	
		559	95	0	

Vehicle Mix

Heavy Vehicle Percentages

		To			
From		\$	%	&	
		0	0	1	
		0	0	2	
		2	1	0	

Results

Results Summary for whole modelled period

Stream	Max RFC	Max delay (s)	Max Queue (Veh)	Max LOS	Average Demand (Veh/hr)	Total Junction Arrivals (Veh)
B-AC	0.20	9.75	0.2	A	75	113
C-AB	0.18	7.56	0.2	A	87	131
C-A					513	769
A-B					21	32
A-C					387	581

Main Results for each time segment

16:45 - 17:00

Stream	Total Demand (Veh/hr)	Junction Arrivals (Veh)	Capacity (Veh/hr)	RFC	Throughput (Veh/hr)	Start queue (Veh)	End queue (Veh)	Delay (s)	LOS
B-AC	62	15	511	0.121	61	0.0	0.1	7.995	A
C-AB	72	18	618	0.116	71	0.0	0.1	6.577	A
C-A	421	105			421				
A-B	17	4			17				
A-C	318	79			318				

17:00 - 17:15

Stream	Total Demand (Veh/hr)	Junction Arrivals (Veh)	Capacity (Veh/hr)	RFC	Throughput (Veh/hr)	Start queue (Veh)	End queue (Veh)	Delay (s)	LOS
B-AC	74	18	490	0.150	74	0.1	0.2	8.647	A
C-AB	85	21	602	0.142	85	0.1	0.2	6.962	A
C-A	503	126			503				
A-B	21	5			21				
A-C	379	95			379				

17:15 - 17:30

Stream	Total Demand (Veh/hr)	Junction Arrivals (Veh)	Capacity (Veh/hr)	RFC	Throughput (Veh/hr)	Start queue (Veh)	End queue (Veh)	Delay (s)	LOS
B-AC	90	23	460	0.196	90	0.2	0.2	9.733	A
C-AB	105	26	580	0.180	104	0.2	0.2	7.557	A
C-A	615	154			615				
A-B	25	6			25				
A-C	465	116			465				

17:30 - 17:45

Stream	Total Demand (Veh/hr)	Junction Arrivals (Veh)	Capacity (Veh/hr)	RFC	Throughput (Veh/hr)	Start queue (Veh)	End queue (Veh)	Delay (s)	LOS
B-AC	90	23	460	0.196	90	0.2	0.2	9.747	A
C-AB	105	26	580	0.180	105	0.2	0.2	7.563	A
C-A	615	154			615				
A-B	25	6			25				
A-C	465	116			465				

17:45 - 18:00

Stream	Total Demand (Veh/hr)	Junction Arrivals (Veh)	Capacity (Veh/hr)	RFC	Throughput (Veh/hr)	Start queue (Veh)	End queue (Veh)	Delay (s)	LOS
B-AC	74	18	490	0.150	74	0.2	0.2	8.661	A
C-AB	85	21	602	0.142	86	0.2	0.2	6.970	A
C-A	503	126			503				
A-B	21	5			21				
A-C	379	95			379				

18:00 - 18:15

Stream	Total Demand (Veh/hr)	Junction Arrivals (Veh)	Capacity (Veh/hr)	RFC	Throughput (Veh/hr)	Start queue (Veh)	End queue (Veh)	Delay (s)	LOS
B-AC	62	15	511	0.121	62	0.2	0.1	8.023	A
C-AB	72	18	618	0.116	72	0.2	0.1	6.594	A
C-A	421	105			421				
A-B	17	4			17				
A-C	318	79			318				

F.7 J7A_Kennington Rd The Street

Junctions 9
PICADY 9 - Priority Intersection Module
Version: 9.0.2.5947 © Copyright TRL Limited, 2017
For sales and distribution information, program advice and maintenance, contact TRL: +44 (0)1344 770558 software@trl.co.uk www.trlsoftware.co.uk
The users of this computer program for the solution of an engineering problem are in no way relieved of their responsibility for the correctness of the solution

Filename: J7A_Kennington Rd The Street_Base Model.j9
Path: K:\UA008926 Otterpool\D-Calcs\Modelling\DM_it5\Appendix\Appendix Base Models\Picady\J7A Kennington Rd - The St
Report generation date: 20/11/2018 15:40:09

- »Base, AM
- »Base, PM

Summary of junction performance

	AM				PM			
	Queue (Veh)	Delay (s)	RFC	LOS	Queue (Veh)	Delay (s)	RFC	LOS
	Base							
Stream B-ACD	0.0	0.00	0.00	A	0.0	8.22	0.01	A
Stream A-BCD	0.4	9.15	0.26	A	0.5	10.96	0.32	B
Stream D-ABC	0.2	12.23	0.15	B	0.1	10.08	0.11	B
Stream C-ABD	0.0	7.64	0.00	A	0.0	6.23	0.00	A

Values shown are the highest values encountered over all time segments. Delay is the maximum value of average delay per arriving vehicle.

File summary

File Description

Title	J7A Otterpool Park_Base Model
Location	Kennington Rd - The St
Site number	
Date	12/07/2017
Version	
Status	Draft 1
Identifier	
Client	
Jobnumber	
Enumerator	dma78191 [C8Z9W0G2]
Description	

Units

Distance units	Speed units	Traffic units input	Traffic units results	Flow units	Average delay units	Total delay units	Rate of delay units
m	kph	Veh	Veh	perHour	s	-Hour	perHour

Analysis Options

Vehicle length (m)	Calculate Queue Percentiles	Calculate detailed queueing delay	Calculate residual capacity	RFC Threshold	Average Delay threshold (s)	Queue threshold (PCU)
5.75				0.85	36.00	20.00

Demand Set Summary

ID	Scenario name	Time Period name	Description	Traffic profile type	Start time (HH:mm)	Finish time (HH:mm)	Time segment length (min)	Run automatically
D1	Base	AM	J7A Otterpool Park AM PEAK	ONE HOUR	07:45	09:15	15	9
D2	Base	PM	J7A Otterpool Park PM PEAK	ONE HOUR	16:45	18:15	15	9

Analysis Set Details

ID	Include in report	Network flow scaling factor (%)	Network capacity scaling factor (%)
A1	9	100.000	100.000

Base, AM

Data Errors and Warnings

No errors or warnings

Junction Network

Junctions

Junction	Name	Junction Type	Major road direction	Junction Delay (s)	Junction LOS
1	untitled	Right-Left Stagger	Two-way	1.37	A

Junction Network Options

Driving side	Lighting
Left	Normal/unknown

Arms

Arms

Arm	Name	Description	Arm type
A	A2070 Kennington Rd Northbound		Major
B	The Street Eastbound		Minor
C	A2070 Kennington Rd Southbound		Major
D	The Street Westbound		Minor

Major Arm Geometry

Arm	Width of carriageway (m)	Has kerbed central reserve	Width of kerbed central reserve (m)	Has right turn bay	Width for right turn (m)	Visibility for right turn (m)	Blocks?	Blocking queue (PCU)
A	6.20	9	2.69	9	2.80	100.0	9	4.00
C	6.20	9	2.69	9	2.80	100.0	9	2.00

Geometries for Arm C are measured opposite Arm B. Geometries for Arm A (if relevant) are measured opposite Arm D.

Minor Arm Geometry

Arm	Minor arm type	Lane width (m)	Visibility to left (m)	Visibility to right (m)
B	One lane	2.50	37	77
D	One lane	2.61	99	41

Slope / Intercept / Capacity

Priority Intersection Slopes and Intercepts

Junction	Stream	Intercept (Veh/hr)	Slope for A-B	Slope for A-C	Slope for A-D	Slope for B-A	Slope for B-D	Slope for C-A	Slope for C-B	Slope for C-D	Slope for D-B	Slope for D-C
1	A-D	673	-	-	-	0.259	0.259	0.259	-	0.259	-	-
1	B-AD	531	0.090	0.229	-	-	-	0.144	0.327	0.144	0.090	0.229
1	B-C	639	0.097	0.245	-	-	-	-	-	-	0.097	0.245
1	C-B	673	0.259	0.259	-	-	-	-	-	-	0.259	0.259
1	D-A	624	-	-	-	0.240	0.095	0.240	-	0.095	-	-
1	D-BC	540	0.146	0.146	0.332	0.232	0.092	0.232	-	0.092	-	-

The slopes and intercepts shown above do NOT include any corrections or adjustments.

Streams may be combined, in which case capacity will be adjusted.

Values are shown for the first time segment only; they may differ for subsequent time segments.

Traffic Demand

Demand Set Details

ID	Scenario name	Time Period name	Description	Traffic profile type	Start time (HH:mm)	Finish time (HH:mm)	Time segment length (min)	Run automatically
D1	Base	AM	J7A Otterpool Park AM PEAK	ONE HOUR	07:45	09:15	15	9

Vehicle mix varies over turn	Vehicle mix varies over entry	Vehicle mix source	PCU Factor for a HV (PCU)
9	9	HV Percentages	2.00

Demand overview (Traffic)

Arm	Linked arm	Profile type	Use O-D data	Average Demand (Veh/hr)	Scaling Factor (%)
A		ONE HOUR	9	797	100.000
B		ONE HOUR	9	2	100.000
C		ONE HOUR	9	458	100.000
D		ONE HOUR	9	48	100.000

Origin -Destination Data

Demand (Veh/hr)

		To				
From		\$	%	&	'	
		0	1	669	127	
		1	0	0	1	
		394	2	0	62	
		24	1	23	0	

Vehicle Mix

Heavy Vehicle Percentages

		To				
From		\$	%	&	'	
		0	0	1	2	
		0	0	0	0	
		2	0	0	2	
		8	0	0	0	

Results

Results Summary for whole modelled period

Stream	Max RFC	Max delay (s)	Max Queue (Veh)	Max LOS	Average Demand (Veh/hr)	Total Junction Arrivals (Veh)
B-ACD	0.00	0.00	0.0	A	0	0
A-BCD	0.26	9.15	0.4	A	117	175
A-B					0.92	1
A-C					613	920
D-ABC	0.15	12.23	0.2	B	44	66
C-ABD	0.00	7.64	0.0	A	2	3
C-D					57	85
C-A					362	542

Main Results for each time segment

07:45 - 08:00

Stream	Total Demand (Veh/hr)	Junction Arrivals (Veh)	Capacity (Veh/hr)	RFC	Throughput (Veh/hr)	Start queue (Veh)	End queue (Veh)	Delay (s)	LOS
B-ACD	0	0	422	0.000	0	0.0	0.0	0.000	A
A-BCD	96	24	572	0.167	95	0.0	0.2	7.539	A
A-B	0.75	0.19			0.75				
A-C	504	126			504				
D-ABC	36	9	420	0.086	36	0.0	0.1	9.365	A
C-ABD	2	0.38	537	0.003	1	0.0	0.0	6.725	A
C-D	47	12			47				
C-A	297	74			297				

08:00 - 08:15

Stream	Total Demand (Veh/hr)	Junction Arrivals (Veh)	Capacity (Veh/hr)	RFC	Throughput (Veh/hr)	Start queue (Veh)	End queue (Veh)	Delay (s)	LOS
B-ACD	0	0	390	0.000	0	0.0	0.0	0.000	A
A-BCD	114	29	555	0.206	114	0.2	0.3	8.159	A
A-B	0.90	0.22			0.90				
A-C	601	150			601				
D-ABC	43	11	390	0.111	43	0.1	0.1	10.367	B
C-ABD	2	0.45	510	0.004	2	0.0	0.0	7.079	A
C-D	56	14			56				
C-A	354	89			354				

08:15 - 08:30

Stream	Total Demand (Veh/hr)	Junction Arrivals (Veh)	Capacity (Veh/hr)	RFC	Throughput (Veh/hr)	Start queue (Veh)	End queue (Veh)	Delay (s)	LOS
B-ACD	0	0	346	0.000	0	0.0	0.0	0.000	A
A-BCD	141	35	534	0.264	140	0.3	0.4	9.136	A
A-B	1	0.27			1				
A-C	736	184			736				
D-ABC	53	13	347	0.152	53	0.1	0.2	12.211	B
C-ABD	2	0.55	474	0.005	2	0.0	0.0	7.635	A
C-D	68	17			68				
C-A	434	108			434				

08:30 - 08:45

Stream	Total Demand (Veh/hr)	Junction Arrivals (Veh)	Capacity (Veh/hr)	RFC	Throughput (Veh/hr)	Start queue (Veh)	End queue (Veh)	Delay (s)	LOS
B-ACD	0	0	346	0.000	0	0.0	0.0	0.000	A
A-BCD	141	35	534	0.264	141	0.4	0.4	9.154	A
A-B	1	0.27			1				
A-C	736	184			736				
D-ABC	53	13	347	0.152	53	0.2	0.2	12.232	B
C-ABD	2	0.55	474	0.005	2	0.0	0.0	7.635	A
C-D	68	17			68				
C-A	434	108			434				

08:45 - 09:00

Stream	Total Demand (Veh/hr)	Junction Arrivals (Veh)	Capacity (Veh/hr)	RFC	Throughput (Veh/hr)	Start queue (Veh)	End queue (Veh)	Delay (s)	LOS
B-ACD	0	0	390	0.000	0	0.0	0.0	0.000	A
A-BCD	114	29	555	0.206	115	0.4	0.3	8.181	A
A-B	0.90	0.22			0.90				
A-C	601	150			601				
D-ABC	43	11	390	0.111	43	0.2	0.1	10.390	B
C-ABD	2	0.45	510	0.004	2	0.0	0.0	7.080	A
C-D	56	14			56				
C-A	354	89			354				

09:00 - 09:15

Stream	Total Demand (Veh/hr)	Junction Arrivals (Veh)	Capacity (Veh/hr)	RFC	Throughput (Veh/hr)	Start queue (Veh)	End queue (Veh)	Delay (s)	LOS
B-ACD	0	0	422	0.000	0	0.0	0.0	0.000	A
A-BCD	96	24	572	0.167	96	0.3	0.2	7.573	A
A-B	0.75	0.19			0.75				
A-C	504	126			504				
D-ABC	36	9	420	0.086	36	0.1	0.1	9.393	A
C-ABD	2	0.38	537	0.003	2	0.0	0.0	6.725	A
C-D	47	12			47				
C-A	297	74			297				

Base, PM

Data Errors and Warnings

No errors or warnings

Junction Network

Junctions

Junction	Name	Junction Type	Major road direction	Junction Delay (s)	Junction LOS
1	untitled	Right-Left Stagger	Two-way	1.68	A

Junction Network Options

Driving side	Lighting
Left	Normal/unknown

Traffic Demand

Demand Set Details

ID	Scenario name	Time Period name	Description	Traffic profile type	Start time (HH:mm)	Finish time (HH:mm)	Time segment length (min)	Run automatically
D2	Base	PM	J7A Otterpool Park PM PEAK	ONE HOUR	16:45	18:15	15	9

Vehicle mix varies over turn	Vehicle mix varies over entry	Vehicle mix source	PCU Factor for a HV (PCU)
9	9	HV Percentages	2.00

Demand overview (Traffic)

Arm	Linked arm	Profile type	Use O-D data	Average Demand (Veh/hr)	Scaling Factor (%)
A		ONE HOUR	9	454	100.000
B		ONE HOUR	9	5	100.000
C		ONE HOUR	9	676	100.000
D		ONE HOUR	9	40	100.000

Origin -Destination Data

Demand (Veh/hr)

		To				
		\$	%	&	'	
From	\$	0	8	307	139	
	%	2	0	3	0	
	&	610	2	0	64	
	'	32	1	7	0	

Vehicle Mix

Heavy Vehicle Percentages

		To				
		\$	%	&	'	
From	\$	0	0	1	0	
	%	0	0	0	0	
	&	1	0	0	0	
	'	0	0	0	0	

Results

Results Summary for whole modelled period

Stream	Max RFC	Max delay (s)	Max Queue (Veh)	Max LOS	Average Demand (Veh/hr)	Total Junction Arrivals (Veh)
B-ACD	0.01	8.22	0.0	A	5	7
A-BCD	0.32	10.96	0.5	B	128	192
A-B					7	11
A-C					281	422
D-ABC	0.11	10.08	0.1	B	37	55
C-ABD	0.00	6.23	0.0	A	2	3
C-D					59	88
C-A					560	840

Main Results for each time segment

16:45 - 17:00

Stream	Total Demand (Veh/hr)	Junction Arrivals (Veh)	Capacity (Veh/hr)	RFC	Throughput (Veh/hr)	Start queue (Veh)	End queue (Veh)	Delay (s)	LOS
B-ACD	4	0.94	492	0.008	4	0.0	0.0	7.365	A
A-BCD	105	26	541	0.194	104	0.0	0.2	8.223	A
A-B	6	2			6				
A-C	231	58			231				
D-ABC	30	8	469	0.064	30	0.0	0.1	8.197	A
C-ABD	2	0.38	610	0.002	1	0.0	0.0	5.918	A
C-D	48	12			48				
C-A	459	115			459				

17:00 - 17:15

Stream	Total Demand (Veh/hr)	Junction Arrivals (Veh)	Capacity (Veh/hr)	RFC	Throughput (Veh/hr)	Start queue (Veh)	End queue (Veh)	Delay (s)	LOS
B-ACD	4	1	472	0.010	4	0.0	0.0	7.697	A
A-BCD	125	31	516	0.243	125	0.2	0.3	9.206	A
A-B	7	2			7				
A-C	276	69			276				
D-ABC	36	9	441	0.082	36	0.1	0.1	8.887	A
C-ABD	2	0.45	597	0.003	2	0.0	0.0	6.044	A
C-D	58	14			58				
C-A	548	137			548				

17:15 - 17:30

Stream	Total Demand (Veh/hr)	Junction Arrivals (Veh)	Capacity (Veh/hr)	RFC	Throughput (Veh/hr)	Start queue (Veh)	End queue (Veh)	Delay (s)	LOS
B-ACD	6	1	443	0.012	5	0.0	0.0	8.224	A
A-BCD	154	39	483	0.320	154	0.3	0.5	10.923	B
A-B	9	2			9				
A-C	337	84			337				
D-ABC	44	11	401	0.110	44	0.1	0.1	10.079	B
C-ABD	2	0.55	580	0.004	2	0.0	0.0	6.226	A
C-D	70	18			70				
C-A	672	168			672				

17:30 - 17:45

Stream	Total Demand (Veh/hr)	Junction Arrivals (Veh)	Capacity (Veh/hr)	RFC	Throughput (Veh/hr)	Start queue (Veh)	End queue (Veh)	Delay (s)	LOS
B-ACD	6	1	443	0.012	6	0.0	0.0	8.224	A
A-BCD	154	39	483	0.320	154	0.5	0.5	10.962	B
A-B	9	2			9				
A-C	337	84			337				
D-ABC	44	11	401	0.110	44	0.1	0.1	10.084	B
C-ABD	2	0.55	580	0.004	2	0.0	0.0	6.226	A
C-D	70	18			70				
C-A	672	168			672				

17:45 - 18:00

Stream	Total Demand (Veh/hr)	Junction Arrivals (Veh)	Capacity (Veh/hr)	RFC	Throughput (Veh/hr)	Start queue (Veh)	End queue (Veh)	Delay (s)	LOS
B-ACD	4	1	472	0.010	5	0.0	0.0	7.698	A
A-BCD	125	31	516	0.243	126	0.5	0.3	9.248	A
A-B	7	2			7				
A-C	276	69			276				
D-ABC	36	9	441	0.082	36	0.1	0.1	8.901	A
C-ABD	2	0.45	597	0.003	2	0.0	0.0	6.046	A
C-D	58	14			58				
C-A	548	137			548				

18:00 - 18:15

Stream	Total Demand (Veh/hr)	Junction Arrivals (Veh)	Capacity (Veh/hr)	RFC	Throughput (Veh/hr)	Start queue (Veh)	End queue (Veh)	Delay (s)	LOS
B-ACD	4	0.94	492	0.008	4	0.0	0.0	7.366	A
A-BCD	105	26	541	0.194	105	0.3	0.2	8.271	A
A-B	6	2			6				
A-C	231	58			231				
D-ABC	30	8	469	0.064	30	0.1	0.1	8.214	A
C-ABD	2	0.38	610	0.002	2	0.0	0.0	5.921	A
C-D	48	12			48				
C-A	459	115			459				

F.8 J7B_A20 Hythe Rd The Street

<h1>Junctions 9</h1>
<h2>ARCADY 9 - Roundabout Module</h2>
Version: 9.0.2.5947 © Copyright TRL Limited, 2017
For sales and distribution information, program advice and maintenance, contact TRL: +44 (0)1344 770558 software@trl.co.uk www.trlsoftware.co.uk
The users of this computer program for the solution of an engineering problem are in no way relieved of their responsibility for the correctness of the solution

Filename: J7B_A20 Hythe Rd The St_Base Model.j9

Path: K:\UA008926 Otterpool\D-Calcs\Modelling\DM_it5\Appendix\Appendix Base Models\Arcady\J7B A20Hythe Rd-The Street

Report generation date: 20/11/2018 15:27:32

»Base, AM

»Base, PM

Summary of junction performance

	AM				PM			
	Queue (Veh)	Delay (s)	RFC	LOS	Queue (Veh)	Delay (s)	RFC	LOS
	Base							
Arm A	2.1	10.88	0.68	B	1.3	8.42	0.56	A
Arm B	0.4	5.03	0.30	A	0.9	5.83	0.46	A
Arm C	0.7	3.51	0.41	A	1.2	4.56	0.54	A
Arm D	0.9	14.44	0.48	B	1.3	23.45	0.56	C

Values shown are the highest values encountered over all time segments. Delay is the maximum value of average delay per arriving vehicle.

File summary

File Description

Title	J7B Otterpool Park_Base Model AM PEAK
Location	A20 Hythe Road - The St
Site number	
Date	27/06/2017
Version	
Status	Draft 1
Identifier	
Client	
Jobnumber	
Enumerator	dma78191 [C8Z9W0G2]
Description	

Units

Distance units	Speed units	Traffic units input	Traffic units results	Flow units	Average delay units	Total delay units	Rate of delay units
m	kph	Veh	Veh	perHour	s	-Hour	perHour

Analysis Options

Vehicle length (m)	Calculate Queue Percentiles	Calculate detailed queueing delay	Calculate residual capacity	RFC Threshold	Average Delay threshold (s)	Queue threshold (PCU)
5.75				0.85	36.00	20.00

Demand Set Summary

ID	Scenario name	Time Period name	Traffic profile type	Start time (HH:mm)	Finish time (HH:mm)	Time segment length (min)	Run automatically
D1	Base	AM	ONE HOUR	07:45	09:15	15	9
D2	Base	PM	ONE HOUR	16:30	18:00	15	9

Analysis Set Details

ID	Include in report	Network flow scaling factor (%)	Network capacity scaling factor (%)
A1	9	100.000	100.000

Base, AM

Data Errors and Warnings

No errors or warnings

Junction Network

Junctions

Junction	Name	Junction Type	Arm order	Junction Delay (s)	Junction LOS
1	untitled	Standard Roundabout	A, B, C, D	7.63	A

Junction Network Options

Driving side	Lighting
Left	Normal/unknown

Arms

Arms

Arm	Name	Description
A	A20 Hythe Road Westbound	
B	Tesco Access	
C	A20 Hythe Road Eastbound	
D	The Street	

Roundabout Geometry

Arm	V - Approach road half - width (m)	E - Entry width (m)	I' - Effective flare length (m)	R - Entry radius (m)	D - Inscribed circle diameter (m)	PHI - Conflict (entry) angle (deg)	Exit only
A	3.66	4.26	19.8	46.4	37.5	32.0	
B	3.68	6.04	21.9	7.7	37.5	37.0	
C	3.76	7.19	21.8	23.6	37.5	28.0	
D	3.00	3.00	0.0	14.2	37.5	36.0	

Slope / Intercept / Capacity

Roundabout Slope and Intercept used in model

Arm	Final slope	Final intercept (PCU/hr)
A	0.573	1301
B	0.571	1478
C	0.683	1857
D	0.468	872

The slope and intercept shown above include any corrections and adjustments.

Traffic Demand

Demand Set Details

ID	Scenario name	Time Period name	Traffic profile type	Start time (HH:mm)	Finish time (HH:mm)	Time segment length (min)	Run automatically
D1	Base	AM	ONE HOUR	07:45	09:15	15	9

Vehicle mix varies over turn	Vehicle mix varies over entry	Vehicle mix source	PCU Factor for a HV (PCU)
9	9	HV Percentages	2.00

Demand overview (Traffic)

Arm	Linked arm	Profile type	Use O-D data	Average Demand (Veh/hr)	Scaling Factor (%)
A		ONE HOUR	9	627	100.000
B		ONE HOUR	9	279	100.000
C		ONE HOUR	9	660	100.000
D		ONE HOUR	9	212	100.000

Origin -Destination Data

Demand (Veh/hr)

From		To			
		\$	%	&	'
From	\$	2	105	520	0
	%	67	1	211	0
	&	440	214	6	0
	'	39	34	139	0

Vehicle Mix

Heavy Vehicle Percentages

From		To			
		\$	%	&	'
From	\$	0	3	3	0
	%	1	0	3	0
	&	4	1	0	0
	'	3	0	0	0

Results

Results Summary for whole modelled period

Arm	Max RFC	Max delay (s)	Max Queue (Veh)	Max LOS	Average Demand (Veh/hr)	Total Junction Arrivals (Veh)
A	0.68	10.88	2.1	B	575	863
B	0.30	5.03	0.4	A	256	384
C	0.41	3.51	0.7	A	606	908
D	0.48	14.44	0.9	B	195	292

Main Results for each time segment

07:45 - 08:00

Arm	Total Demand (Veh/hr)	Junction Arrivals (Veh)	Circulating flow (Veh/hr)	Capacity (Veh/hr)	RFC	Throughput (Veh/hr)	Throughput (exit side) (Veh/hr)	Start queue (Veh)	End queue (Veh)	Delay (s)	LOS
A	472	118	295	1098	0.430	469	411	0.0	0.7	5.694	A
B	210	53	499	1157	0.181	209	265	0.0	0.2	3.792	A
C	497	124	52	1768	0.281	495	655	0.0	0.4	2.825	A
D	160	40	548	605	0.264	158	0	0.0	0.4	8.057	A

08:00 - 08:15

Arm	Total Demand (Veh/hr)	Junction Arrivals (Veh)	Circulating flow (Veh/hr)	Capacity (Veh/hr)	RFC	Throughput (Veh/hr)	Throughput (exit side) (Veh/hr)	Start queue (Veh)	End queue (Veh)	Delay (s)	LOS
A	564	141	354	1066	0.529	562	492	0.7	1.1	7.130	A
B	251	63	598	1101	0.228	251	318	0.2	0.3	4.233	A
C	593	148	63	1761	0.337	593	786	0.4	0.5	3.080	A
D	191	48	656	553	0.344	190	0	0.4	0.5	9.888	A

08:15 - 08:30

Arm	Total Demand (Veh/hr)	Junction Arrivals (Veh)	Circulating flow (Veh/hr)	Capacity (Veh/hr)	RFC	Throughput (Veh/hr)	Throughput (exit side) (Veh/hr)	Start queue (Veh)	End queue (Veh)	Delay (s)	LOS
A	690	173	432	1022	0.676	687	602	1.1	2.0	10.633	B
B	307	77	730	1025	0.300	307	389	0.3	0.4	5.006	A
C	727	182	77	1751	0.415	726	960	0.5	0.7	3.505	A
D	233	58	803	483	0.483	232	0	0.5	0.9	14.247	B

08:30 - 08:45

Arm	Total Demand (Veh/hr)	Junction Arrivals (Veh)	Circulating flow (Veh/hr)	Capacity (Veh/hr)	RFC	Throughput (Veh/hr)	Throughput (exit side) (Veh/hr)	Start queue (Veh)	End queue (Veh)	Delay (s)	LOS
A	690	173	434	1021	0.676	690	603	2.0	2.1	10.877	B
B	307	77	734	1023	0.300	307	390	0.4	0.4	5.027	A
C	727	182	77	1751	0.415	727	964	0.7	0.7	3.512	A
D	233	58	804	483	0.484	233	0	0.9	0.9	14.438	B

08:45 - 09:00

Arm	Total Demand (Veh/hr)	Junction Arrivals (Veh)	Circulating flow (Veh/hr)	Capacity (Veh/hr)	RFC	Throughput (Veh/hr)	Throughput (exit side) (Veh/hr)	Start queue (Veh)	End queue (Veh)	Delay (s)	LOS
A	564	141	356	1064	0.530	567	494	2.1	1.1	7.294	A
B	251	63	604	1098	0.229	251	319	0.4	0.3	4.256	A
C	593	148	63	1761	0.337	594	792	0.7	0.5	3.087	A
D	191	48	657	553	0.345	192	0	0.9	0.5	10.028	B

09:00 - 09:15

Arm	Total Demand (Veh/hr)	Junction Arrivals (Veh)	Circulating flow (Veh/hr)	Capacity (Veh/hr)	RFC	Throughput (Veh/hr)	Throughput (exit side) (Veh/hr)	Start queue (Veh)	End queue (Veh)	Delay (s)	LOS
A	472	118	297	1097	0.430	474	413	1.1	0.8	5.786	A
B	210	53	504	1155	0.182	210	267	0.3	0.2	3.815	A
C	497	124	53	1768	0.281	497	661	0.5	0.4	2.836	A
D	160	40	550	604	0.264	160	0	0.5	0.4	8.129	A

Base, PM

Data Errors and Warnings

No errors or warnings

Junction Network

Junctions

Junction	Name	Junction Type	Arm order	Junction Delay (s)	Junction LOS
1	untitled	Standard Roundabout	A, B, C, D	7.51	A

Junction Network Options

Driving side	Lighting
Left	Normal/unknown

Traffic Demand

Demand Set Details

ID	Scenario name	Time Period name	Traffic profile type	Start time (HH:mm)	Finish time (HH:mm)	Time segment length (min)	Run automatically
D2	Base	PM	ONE HOUR	16:30	18:00	15	9

Vehicle mix varies over turn	Vehicle mix varies over entry	Vehicle mix source	PCU Factor for a HV (PCU)
9	9	HV Percentages	2.00

Demand overview (Traffic)

Arm	Linked arm	Profile type	Use O-D data	Average Demand (Veh/hr)	Scaling Factor (%)
A		ONE HOUR	9	504	100.000
B		ONE HOUR	9	481	100.000
C		ONE HOUR	9	844	100.000
D		ONE HOUR	9	180	100.000

Origin -Destination Data

Demand (Veh/hr)

		To				
		\$	%	&	'	
From	\$	1	105	398	0	
	%	154	0	327	0	
	&	500	342	2	0	
	'	43	37	100	0	

Vehicle Mix

Heavy Vehicle Percentages

		To				
		\$	%	&	'	
From	\$	0	0	2	0	
	%	1	0	1	0	
	&	2	0	0	0	
	'	0	0	0	0	

Results

Results Summary for whole modelled period

Arm	Max RFC	Max delay (s)	Max Queue (Veh)	Max LOS	Average Demand (Veh/hr)	Total Junction Arrivals (Veh)
A	0.56	8.42	1.3	A	462	694
B	0.46	5.83	0.9	A	441	662
C	0.54	4.56	1.2	A	774	1162
D	0.56	23.45	1.3	C	165	248

Main Results for each time segment

16:30 - 16:45

Arm	Total Demand (Veh/hr)	Junction Arrivals (Veh)	Circulating flow (Veh/hr)	Capacity (Veh/hr)	RFC	Throughput (Veh/hr)	Throughput (exit side) (Veh/hr)	Start queue (Veh)	End queue (Veh)	Delay (s)	LOS
A	379	95	360	1078	0.352	377	523	0.0	0.5	5.124	A
B	362	91	375	1248	0.290	360	363	0.0	0.4	4.048	A
C	635	159	116	1756	0.362	633	619	0.0	0.6	3.199	A
D	136	34	749	517	0.262	134	0	0.0	0.4	9.366	A

16:45 - 17:00

Arm	Total Demand (Veh/hr)	Junction Arrivals (Veh)	Circulating flow (Veh/hr)	Capacity (Veh/hr)	RFC	Throughput (Veh/hr)	Throughput (exit side) (Veh/hr)	Start queue (Veh)	End queue (Veh)	Delay (s)	LOS
A	453	113	431	1038	0.437	452	627	0.5	0.8	6.139	A
B	432	108	449	1205	0.359	432	434	0.4	0.6	4.654	A
C	759	190	139	1740	0.436	758	742	0.6	0.8	3.661	A
D	162	40	897	447	0.362	161	0	0.4	0.6	12.543	B

17:00 - 17:15

Arm	Total Demand (Veh/hr)	Junction Arrivals (Veh)	Circulating flow (Veh/hr)	Capacity (Veh/hr)	RFC	Throughput (Veh/hr)	Throughput (exit side) (Veh/hr)	Start queue (Veh)	End queue (Veh)	Delay (s)	LOS
A	555	139	527	984	0.564	553	767	0.8	1.3	8.318	A
B	530	132	549	1148	0.461	528	531	0.6	0.8	5.797	A
C	929	232	170	1719	0.541	928	907	0.8	1.2	4.540	A
D	198	50	1098	352	0.563	196	0	0.6	1.2	22.622	C

17:15 - 17:30

Arm	Total Demand (Veh/hr)	Junction Arrivals (Veh)	Circulating flow (Veh/hr)	Capacity (Veh/hr)	RFC	Throughput (Veh/hr)	Throughput (exit side) (Veh/hr)	Start queue (Veh)	End queue (Veh)	Delay (s)	LOS
A	555	139	529	982	0.565	555	768	1.3	1.3	8.420	A
B	530	132	551	1147	0.462	530	533	0.8	0.9	5.834	A
C	929	232	171	1719	0.541	929	910	1.2	1.2	4.559	A
D	198	50	1100	351	0.564	198	0	1.2	1.3	23.451	C

17:30 - 17:45

Arm	Total Demand (Veh/hr)	Junction Arrivals (Veh)	Circulating flow (Veh/hr)	Capacity (Veh/hr)	RFC	Throughput (Veh/hr)	Throughput (exit side) (Veh/hr)	Start queue (Veh)	End queue (Veh)	Delay (s)	LOS
A	453	113	435	1036	0.438	455	629	1.3	0.8	6.224	A
B	432	108	453	1203	0.359	434	437	0.9	0.6	4.687	A
C	759	190	140	1740	0.436	760	747	1.2	0.8	3.682	A
D	162	40	900	446	0.363	165	0	1.3	0.6	12.918	B

17:45 - 18:00

Arm	Total Demand (Veh/hr)	Junction Arrivals (Veh)	Circulating flow (Veh/hr)	Capacity (Veh/hr)	RFC	Throughput (Veh/hr)	Throughput (exit side) (Veh/hr)	Start queue (Veh)	End queue (Veh)	Delay (s)	LOS
A	379	95	363	1076	0.353	380	526	0.8	0.5	5.182	A
B	362	91	378	1246	0.291	363	365	0.6	0.4	4.079	A
C	635	159	117	1755	0.362	636	624	0.8	0.6	3.220	A
D	136	34	753	515	0.263	136	0	0.6	0.4	9.521	A

F.9 J8_Otterpool Ln A20 Ashford Rd

Full Input Data And Results
Full Input Data And Results

User and Project Details

Project:	Otterpool Park
Title:	A20 Ashford Rd/ B2067 Otterpool Ln
Location:	B2067 Otterpool Ln - A20 Ashford Rd
Additional detail:	
File name:	J8_A20 Ashford Rd Otterpool Ln_Base Model.lsg3x
Author:	Diego Moreno-Sosa
Company:	ARCADIS UK
Address:	

Network Layout Diagram

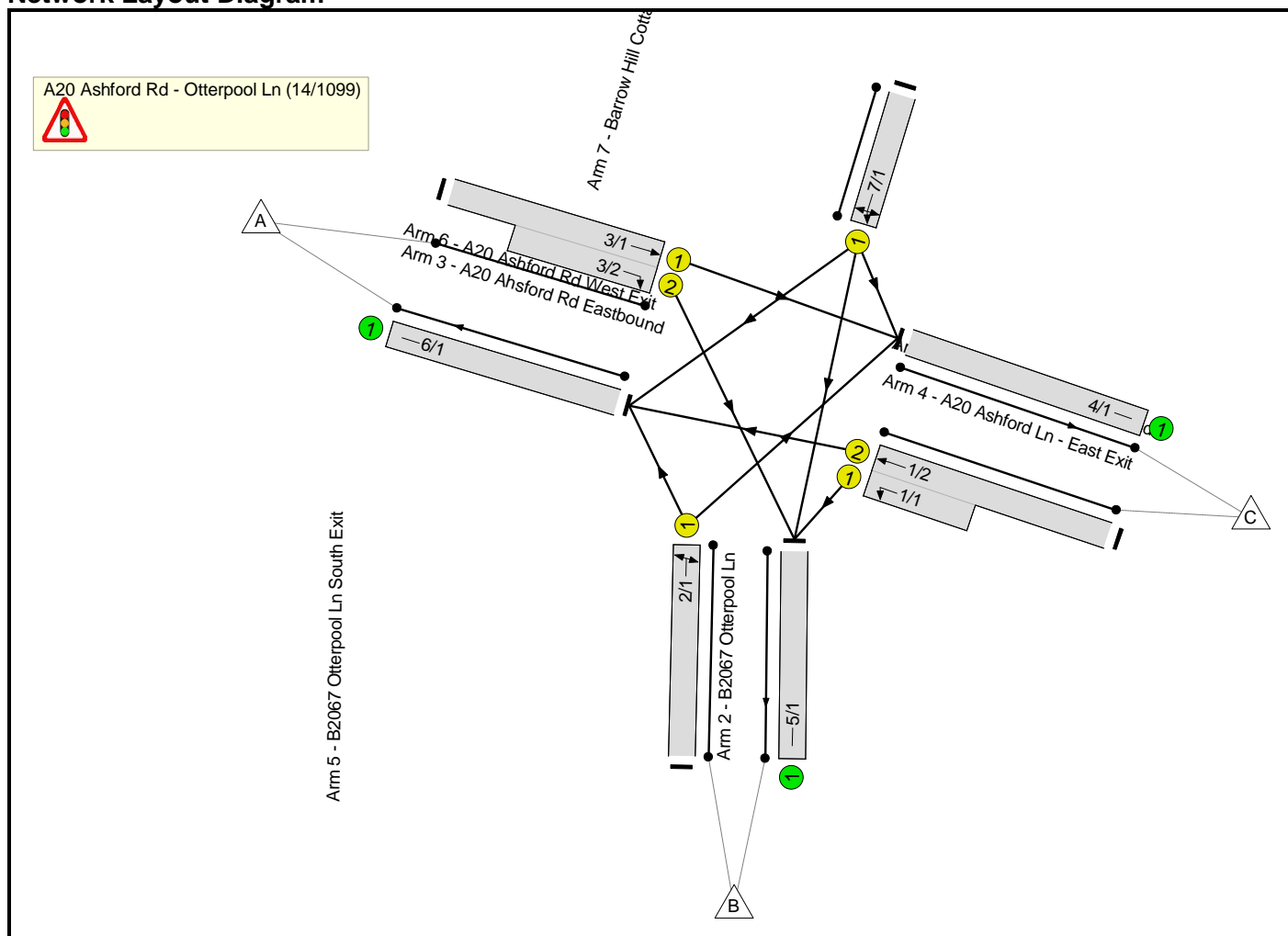

Full Input Data And Results

Phase Input Data

Phase Name	Phase Type	Assoc. Phase	Street Min	Cont Min
A	Traffic		7	7
B	Traffic		7	7
C	Traffic		7	7
D	Traffic		7	7
E	Traffic		7	7
F	Pedestrian		7	7
G	Dummy		3	3
H	Dummy		7	7

Phase Intergreens Matrix

	Starting Phase								
	A	B	C	D	E	F	G	H	
Terminating Phase	A	7	7	-	10	9	5	-	
	B	7	8	9	11	7	5	7	
	C	6	5	-	5	9	3	6	
	D	-	5	-	8	-	5	5	
	E	5	5	5	5	8	3	5	
	F	15	15	15	-	8	15	15	
	G	2	2	2	2	2	0	-	
	H	-	0	6	5	0	0	-	

Phases in Stage

Stage No.	Phases in Stage
1	A D
2	A H
3	D F
4	C D
5	E
6	B

Stage Diagram

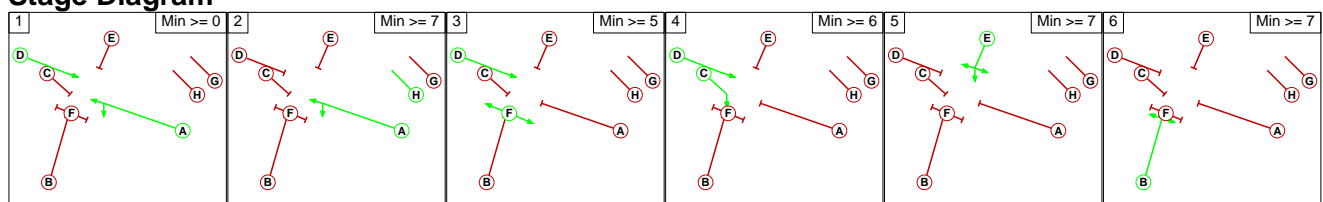

Phase Delays

Term. Stage	Start Stage	Phase	Type	Value	Cont value
There are no Phase Delays defined					

Full Input Data And Results

Traffic Flows, Desired

Scenario 1: 'Base AM' (FG1: 'AM PEAK', Plan 1: 'Network Control Plan 1')

Desired Flow :

		Destination			
		A	B	C	Tot.
Origin	A	0	77	188	265
	B	73	0	159	232
	C	207	188	0	395
	Tot.	280	265	347	892

Scenario 2: 'Base PM' (FG2: 'PM PEAK', Plan 1: 'Network Control Plan 1')

Desired Flow :

		Destination			
		A	B	C	Tot.
Origin	A	0	74	210	284
	B	95	0	245	340
	C	167	79	0	246
	Tot.	262	153	455	870

Scenario 1: 'Base AM' (FG1: 'AM PEAK', Plan 1: 'Network Control Plan 1')

Stage Sequence Diagram

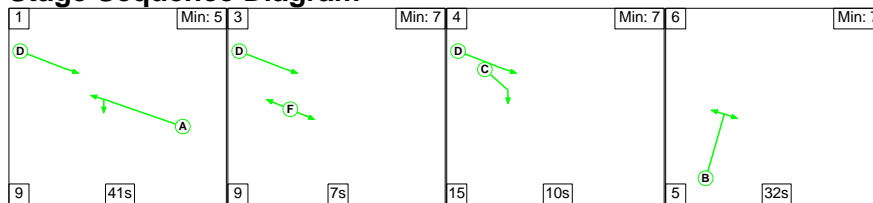

Stage Timings

Stage	1	3	4	6
Duration	41	7	10	32
Change Point	0	50	66	91

Signal Timings Diagram

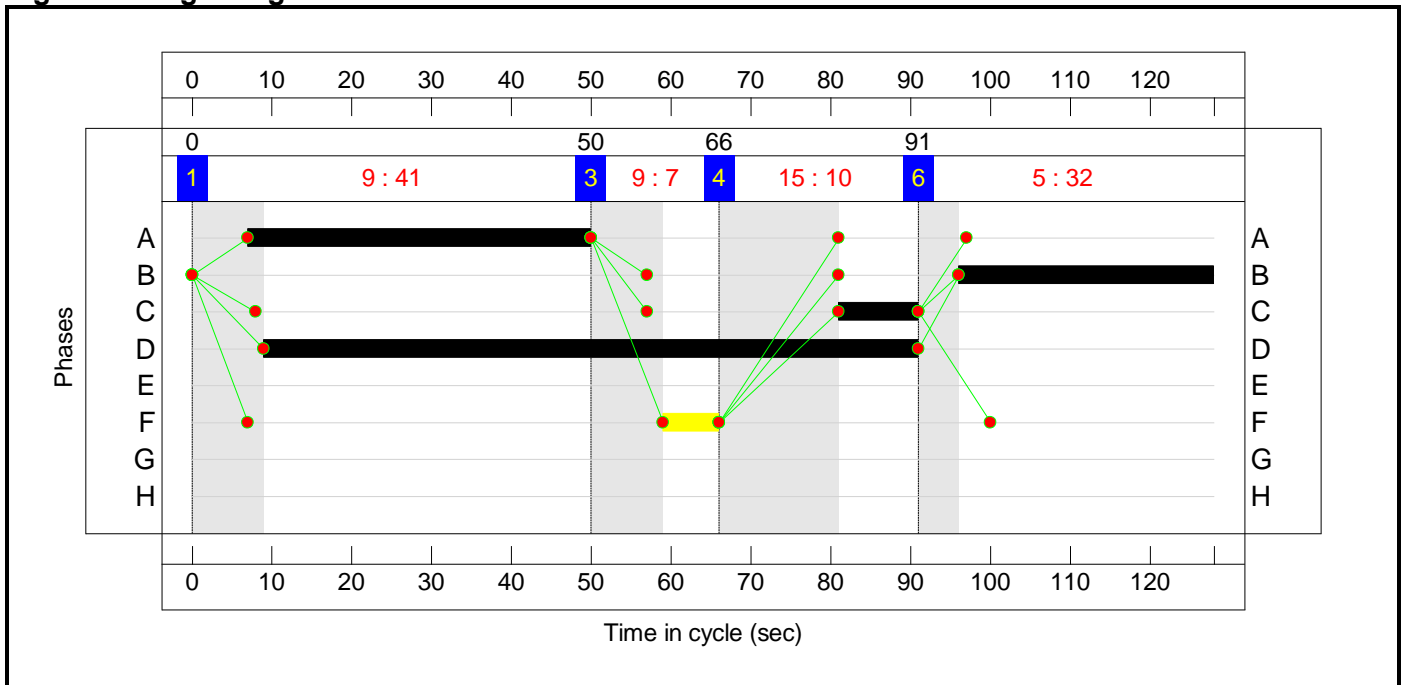

Full Input Data And Results
Network Layout Diagram

Full Input Data And Results

A20 Ashford Rd - Otterpool Ln (14/1099)
 PRC: 89.9 %
 Total Traffic Delay: 8.9 pcuHr

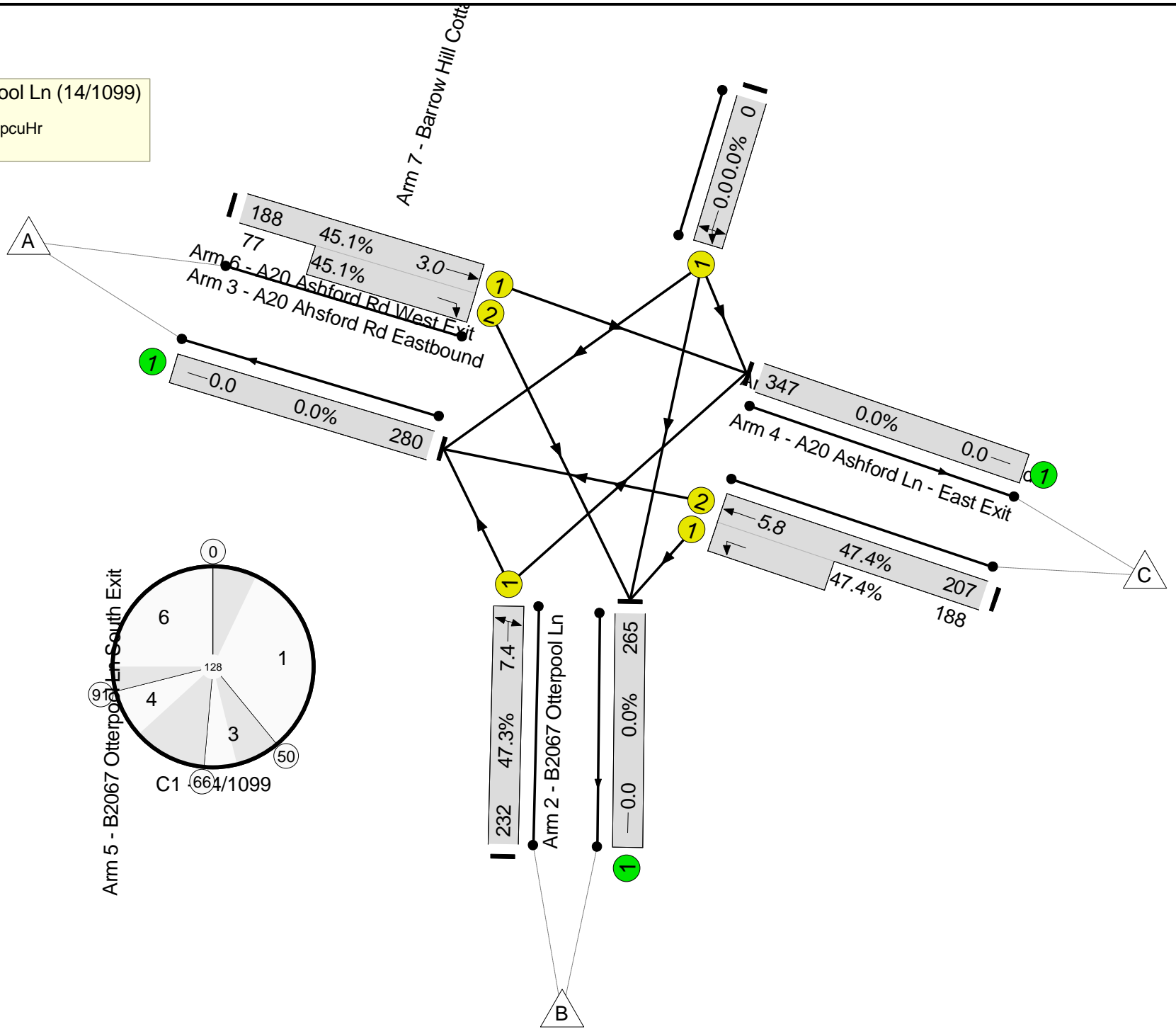
Full Input Data And Results

Network Results

Scenario 1: 'Base AM' (FG1: 'AM PEAK', Plan 1: 'Network Control Plan 1')

Item	Lane Description	Lane Type	Total Green (s)	Arrow Green (s)	Demand Flow (pcu)	Sat Flow (pcu/Hr)	Capacity (pcu)	Deg Sat (%)	Arriving (pcu)
Network: A20 Ashford Rd/ B2067 Otterpool Ln	-	-	-	-	-	-	-	47.4%	-
A20 Ashford Rd - Otterpool Ln (14/1099)	-	-	-	-	-	-	-	47.4%	-
1/2+1/1	A20 Ashford Rd Westbound Left Ahead	U	43	-	395	2065:1762	437+397	47.4 : 47.4%	395
2/1	B2067 Otterpool Ln Right Left	U	32	-	232	1904	491	47.3%	232
3/1+3/2	A20 Ashford Rd Eastbound Ahead Right	U	82:10	-	265	1850:1986	417+171	45.1 : 45.1%	265
4/1	A20 Ashford Ln - East Exit	U	-	-	347	Inf	Inf	0.0%	347
5/1	B2067 Otterpool Ln South Exit	U	-	-	265	Inf	Inf	0.0%	265
6/1	A20 Ashford Rd West Exit	U	-	-	280	Inf	Inf	0.0%	280
7/1	Barrow Hill Cottages Left Ahead Right	U	0	-	0	1800	0	0.0%	0

Full Input Data And Results

Item	Leaving (pcu)	Turners In Intergreen (pcu)	Uniform Delay (pcuHr)	Rand + Oversat Delay (pcuHr)	Total Delay (pcuHr)	Av. Delay Per PCU (s/pcu)	Max. Back of Uniform Queue (pcu)	Rand + Oversat Queue (pcu)	Mean Max Queue (pcu)
Network: A20 Ashford Rd/ B2067 Otterpool Ln	-	0	7.6	1.3	8.9	-	-	-	-
A20 Ashford Rd - Otterpool Ln (14/1099)	-	0	7.6	1.3	8.9	-	-	-	-
1/2+1/1	395	-	3.4	0.4	3.8	34.8	5.3	0.4	5.8
2/1	232	-	2.6	0.4	3.0	47.1	7.0	0.4	7.4
3/1+3/2	265	-	1.7	0.4	2.1	28.0	2.6	0.4	3.0
4/1	347	-	0.0	0.0	0.0	0.0	0.0	0.0	0.0
5/1	265	-	0.0	0.0	0.0	0.0	0.0	0.0	0.0
6/1	280	-	0.0	0.0	0.0	0.0	0.0	0.0	0.0
7/1	0	-	0.0	0.0	0.0	0.0	0.0	0.0	0.0
<p>C1 - 14/1099 PRC for Signalled Lanes (%): 89.9 Total Delay for Signalled Lanes (pcuHr): 8.92 Cycle Time (s): 128 PRC Over All Lanes (%): 89.9 Total Delay Over All Lanes(pcuHr): 8.92</p>									

Full Input Data And Results

C1 - 14/1099

PRC for Signalled Lanes (%): 93.8
PRC Over All Lanes (%): 93.8

Total Delay for Signalled Lanes (pcuHr): 9.10
Total Delay Over All Lanes(pcuHr): 9.10

Cycle Time (s): 130

F.10 J9_Otterpool Ln Aldington Rd

Junctions 9
PICADY 9 - Priority Intersection Module
Version: 9.0.2.5947 © Copyright TRL Limited, 2017
For sales and distribution information, program advice and maintenance, contact TRL: +44 (0)1344 770558 software@trl.co.uk www.trlsoftware.co.uk
The users of this computer program for the solution of an engineering problem are in no way relieved of their responsibility for the correctness of the solution

Filename: J9_B2067 Otterpool Ln Aldington Rd_Base Model.j9

Path: K:\UA008926 Otterpool\D-Calcs\Modelling\DM_it5\Appendix\Appendix Base Models\Picady\J9 B2067 Otterpool Ln - Aldington Rd

Report generation date: 20/11/2018 15:41:06

»Base, AM

»Base, PM

Summary of junction performance

	AM				PM			
	Queue (Veh)	Delay (s)	RFC	LOS	Queue (Veh)	Delay (s)	RFC	LOS
	Base							
Stream B-AC	0.3	9.67	0.22	A	0.5	11.59	0.34	B
Stream C-AB	0.2	7.49	0.20	A	0.1	6.45	0.11	A

Values shown are the highest values encountered over all time segments. Delay is the maximum value of average delay per arriving vehicle.

File summary

File Description

Title	J9 Otterpool Park_Base Model
Location	B2067 Otterpool Ln - Aldington Rd
Site number	
Date	09/08/2017
Version	
Status	Base
Identifier	
Client	
Jobnumber	
Enumerator	dma78191 [C8Z9W0G2]
Description	

Units

Distance units	Speed units	Traffic units input	Traffic units results	Flow units	Average delay units	Total delay units	Rate of delay units
m	kph	Veh	Veh	perHour	s	-Hour	perHour

Analysis Options

Vehicle length (m)	Calculate Queue Percentiles	Calculate detailed queueing delay	Calculate residual capacity	RFC Threshold	Average Delay threshold (s)	Queue threshold (PCU)
5.75				0.85	36.00	20.00

Demand Set Summary

ID	Scenario name	Time Period name	Description	Traffic profile type	Start time (HH:mm)	Finish time (HH:mm)	Time segment length (min)	Run automatically
D1	Base	AM	J9 Otterpool Park AM PEAK	ONE HOUR	07:45	09:15	15	9
D2	Base	PM	J9 Otterpool Park PM PEAK	ONE HOUR	16:45	18:15	15	9

Analysis Set Details

ID	Include in report	Network flow scaling factor (%)	Network capacity scaling factor (%)
A1	9	100.000	100.000

Base, AM

Data Errors and Warnings

No errors or warnings

Junction Network

Junctions

Junction	Name	Junction Type	Major road direction	Junction Delay (s)	Junction LOS
1	untitled	T-Junction	Two-way	4.47	A

Junction Network Options

Driving side	Lighting
Left	Normal/unknown

Arms

Arms

Arm	Name	Description	Arm type
A	Aldington Road Westbound		Major
B	B2067 Otterpool Lane		Minor
C	Aldington Road Eastbound		Major

Major Arm Geometry

Arm	Width of carriageway (m)	Has kerbed central reserve	Has right turn bay	Visibility for right turn (m)	Blocks?	Blocking queue (PCU)
C	6.17			113.0	9	1.00

Geometries for Arm C are measured opposite Arm B. Geometries for Arm A (if relevant) are measured opposite Arm D.

Minor Arm Geometry

Arm	Minor arm type	Lane width (m)	Visibility to left (m)	Visibility to right (m)
B	One lane	2.44	32	16

Slope / Intercept / Capacity

Priority Intersection Slopes and Intercepts

Junction	Stream	Intercept (Veh/hr)	Slope for A-B	Slope for A-C	Slope for C-A	Slope for C-B
1	B-A	468	0.085	0.214	0.135	0.306
1	B-C	598	0.091	0.230	-	-
1	C-B	639	0.246	0.246	-	-

The slopes and intercepts shown above do NOT include any corrections or adjustments.

Streams may be combined, in which case capacity will be adjusted.

Values are shown for the first time segment only; they may differ for subsequent time segments.

Traffic Demand

Demand Set Details

ID	Scenario name	Time Period name	Description	Traffic profile type	Start time (HH:mm)	Finish time (HH:mm)	Time segment length (min)	Run automatically
D1	Base	AM	J9 Otterpool Park AM PEAK	ONE HOUR	07:45	09:15	15	9

Vehicle mix varies over turn	Vehicle mix varies over entry	Vehicle mix source	PCU Factor for a HV (PCU)
9	9	HV Percentages	2.00

Demand overview (Traffic)

Arm	Linked arm	Profile type	Use O-D data	Average Demand (Veh/hr)	Scaling Factor (%)
A		ONE HOUR	9	136	100.000
B		ONE HOUR	9	98	100.000
C		ONE HOUR	9	161	100.000

Origin -Destination Data

Demand (Veh/hr)

From	To			
	\$	%	&	
	0	86	50	
	35	0	63	
	57	104	0	

Vehicle Mix

Heavy Vehicle Percentages

From	To			
	\$	%	&	
	0	0	2	
	3	0	5	
	0	3	0	

Results

Results Summary for whole modelled period

Stream	Max RFC	Max delay (s)	Max Queue (Veh)	Max LOS	Average Demand (Veh/hr)	Total Junction Arrivals (Veh)
B-AC	0.22	9.67	0.3	A	90	135
C-AB	0.20	7.49	0.2	A	97	145
C-A					51	76
A-B					79	118
A-C					46	69

Main Results for each time segment

07:45 - 08:00

Stream	Total Demand (Veh/hr)	Junction Arrivals (Veh)	Capacity (Veh/hr)	RFC	Throughput (Veh/hr)	Start queue (Veh)	End queue (Veh)	Delay (s)	LOS
B-AC	74	18	494	0.149	73	0.0	0.2	8.539	A
C-AB	79	20	602	0.131	78	0.0	0.2	6.868	A
C-A	42	11			42				
A-B	65	16			65				
A-C	38	9			38				

08:00 - 08:15

Stream	Total Demand (Veh/hr)	Junction Arrivals (Veh)	Capacity (Veh/hr)	RFC	Throughput (Veh/hr)	Start queue (Veh)	End queue (Veh)	Delay (s)	LOS
B-AC	88	22	488	0.180	88	0.2	0.2	8.989	A
C-AB	95	24	600	0.158	95	0.2	0.2	7.123	A
C-A	50	12			50				
A-B	77	19			77				
A-C	45	11			45				

08:15 - 08:30

Stream	Total Demand (Veh/hr)	Junction Arrivals (Veh)	Capacity (Veh/hr)	RFC	Throughput (Veh/hr)	Start queue (Veh)	End queue (Veh)	Delay (s)	LOS
B-AC	108	27	480	0.225	108	0.2	0.3	9.654	A
C-AB	117	29	598	0.196	117	0.2	0.2	7.483	A
C-A	60	15			60				
A-B	95	24			95				
A-C	55	14			55				

08:30 - 08:45

Stream	Total Demand (Veh/hr)	Junction Arrivals (Veh)	Capacity (Veh/hr)	RFC	Throughput (Veh/hr)	Start queue (Veh)	End queue (Veh)	Delay (s)	LOS
B-AC	108	27	480	0.225	108	0.3	0.3	9.668	A
C-AB	117	29	598	0.196	117	0.2	0.2	7.492	A
C-A	60	15			60				
A-B	95	24			95				
A-C	55	14			55				

08:45 - 09:00

Stream	Total Demand (Veh/hr)	Junction Arrivals (Veh)	Capacity (Veh/hr)	RFC	Throughput (Veh/hr)	Start queue (Veh)	End queue (Veh)	Delay (s)	LOS
B-AC	88	22	488	0.180	88	0.3	0.2	9.009	A
C-AB	95	24	600	0.158	95	0.2	0.2	7.133	A
C-A	50	12			50				
A-B	77	19			77				
A-C	45	11			45				

09:00 - 09:15

Stream	Total Demand (Veh/hr)	Junction Arrivals (Veh)	Capacity (Veh/hr)	RFC	Throughput (Veh/hr)	Start queue (Veh)	End queue (Veh)	Delay (s)	LOS
B-AC	74	18	494	0.149	74	0.2	0.2	8.575	A
C-AB	79	20	602	0.131	79	0.2	0.2	6.886	A
C-A	42	11			42				
A-B	65	16			65				
A-C	38	9			38				

Base, PM

Data Errors and Warnings

No errors or warnings

Junction Network

Junctions

Junction	Name	Junction Type	Major road direction	Junction Delay (s)	Junction LOS
1	untitled	T-Junction	Two-way	6.14	A

Junction Network Options

Driving side	Lighting
Left	Normal/unknown

Traffic Demand

Demand Set Details

ID	Scenario name	Time Period name	Description	Traffic profile type	Start time (HH:mm)	Finish time (HH:mm)	Time segment length (min)	Run automatically
D2	Base	PM	J9 Otterpool Park PM PEAK	ONE HOUR	16:45	18:15	15	9

Vehicle mix varies over turn	Vehicle mix varies over entry	Vehicle mix source	PCU Factor for a HV (PCU)
9	9	HV Percentages	2.00

Demand overview (Traffic)

Arm	Linked arm	Profile type	Use O-D data	Average Demand (Veh/hr)	Scaling Factor (%)
A		ONE HOUR	9	75	100.000
B		ONE HOUR	9	145	100.000
C		ONE HOUR	9	117	100.000

Origin -Destination Data

Demand (Veh/hr)

		To			
From		\$	%	&	
		0	29	46	
		91	0	54	
		56	61	0	

Vehicle Mix

Heavy Vehicle Percentages

		To			
From		\$	%	&	
		0	0	0	
		0	0	2	
		4	0	0	

Results

Results Summary for whole modelled period

Stream	Max RFC	Max delay (s)	Max Queue (Veh)	Max LOS	Average Demand (Veh/hr)	Total Junction Arrivals (Veh)
B-AC	0.34	11.59	0.5	B	133	200
C-AB	0.11	6.45	0.1	A	56	85
C-A					51	76
A-B					27	40
A-C					42	63

Main Results for each time segment

16:45 - 17:00

Stream	Total Demand (Veh/hr)	Junction Arrivals (Veh)	Capacity (Veh/hr)	RFC	Throughput (Veh/hr)	Start queue (Veh)	End queue (Veh)	Delay (s)	LOS
B-AC	109	27	482	0.227	108	0.0	0.3	9.602	A
C-AB	46	12	629	0.073	46	0.0	0.1	6.175	A
C-A	42	10			42				
A-B	22	5			22				
A-C	35	9			35				

17:00 - 17:15

Stream	Total Demand (Veh/hr)	Junction Arrivals (Veh)	Capacity (Veh/hr)	RFC	Throughput (Veh/hr)	Start queue (Veh)	End queue (Veh)	Delay (s)	LOS
B-AC	130	33	477	0.273	130	0.3	0.4	10.369	B
C-AB	55	14	627	0.088	55	0.1	0.1	6.292	A
C-A	50	12			50				
A-B	26	7			26				
A-C	41	10			41				

17:15 - 17:30

Stream	Total Demand (Veh/hr)	Junction Arrivals (Veh)	Capacity (Veh/hr)	RFC	Throughput (Veh/hr)	Start queue (Veh)	End queue (Veh)	Delay (s)	LOS
B-AC	160	40	470	0.339	159	0.4	0.5	11.548	B
C-AB	68	17	626	0.108	68	0.1	0.1	6.452	A
C-A	61	15			61				
A-B	32	8			32				
A-C	51	13			51				

17:30 - 17:45

Stream	Total Demand (Veh/hr)	Junction Arrivals (Veh)	Capacity (Veh/hr)	RFC	Throughput (Veh/hr)	Start queue (Veh)	End queue (Veh)	Delay (s)	LOS
B-AC	160	40	470	0.340	160	0.5	0.5	11.588	B
C-AB	68	17	626	0.108	68	0.1	0.1	6.454	A
C-A	61	15			61				
A-B	32	8			32				
A-C	51	13			51				

17:45 - 18:00

Stream	Total Demand (Veh/hr)	Junction Arrivals (Veh)	Capacity (Veh/hr)	RFC	Throughput (Veh/hr)	Start queue (Veh)	End queue (Veh)	Delay (s)	LOS
B-AC	130	33	477	0.273	131	0.5	0.4	10.419	B
C-AB	55	14	627	0.088	55	0.1	0.1	6.294	A
C-A	50	12			50				
A-B	26	7			26				
A-C	41	10			41				

18:00 - 18:15

Stream	Total Demand (Veh/hr)	Junction Arrivals (Veh)	Capacity (Veh/hr)	RFC	Throughput (Veh/hr)	Start queue (Veh)	End queue (Veh)	Delay (s)	LOS
B-AC	109	27	482	0.227	110	0.4	0.3	9.681	A
C-AB	46	12	629	0.073	46	0.1	0.1	6.183	A
C-A	42	10			42				
A-B	22	5			22				
A-C	35	9			35				

F.11 J10_Aldington Rd Stone St

Junctions 9
PICADY 9 - Priority Intersection Module
Version: 9.0.2.5947 © Copyright TRL Limited, 2017
For sales and distribution information, program advice and maintenance, contact TRL: +44 (0)1344 770558 software@trl.co.uk www.trlsoftware.co.uk
The users of this computer program for the solution of an engineering problem are in no way relieved of their responsibility for the correctness of the solution

Filename: J10_Aldington Rd Stone St_Base Model.j9

Path: K:\UA008926 Otterpool\D-Calcs\Modelling\DM_it5\Appendix\Appendix Base Models\Picady\J10 Aldington Rd - Stone St

Report generation date: 20/11/2018 15:42:17

»Base, AM

»Base, PM

Summary of junction performance

	AM				PM			
	Queue (Veh)	Delay (s)	RFC	LOS	Queue (Veh)	Delay (s)	RFC	LOS
	Base							
Stream B-AC	0.6	13.28	0.39	B	1.5	20.29	0.61	C
Stream C-AB	0.0	6.56	0.01	A	0.0	6.09	0.02	A

Values shown are the highest values encountered over all time segments. Delay is the maximum value of average delay per arriving vehicle.

File summary

File Description

Title	J10 Otterpool Park_Base Model
Location	Aldington Rd - Stone St
Site number	
Date	09/08/2017
Version	
Status	Base
Identifier	
Client	
Jobnumber	
Enumerator	dma78191 [C8Z9W0G2]
Description	

Units

Distance units	Speed units	Traffic units input	Traffic units results	Flow units	Average delay units	Total delay units	Rate of delay units
m	kph	Veh	Veh	perHour	s	-Hour	perHour

Analysis Options

Vehicle length (m)	Calculate Queue Percentiles	Calculate detailed queueing delay	Calculate residual capacity	RFC Threshold	Average Delay threshold (s)	Queue threshold (PCU)
5.75				0.85	36.00	20.00

Demand Set Summary

ID	Scenario name	Time Period name	Description	Traffic profile type	Start time (HH:mm)	Finish time (HH:mm)	Time segment length (min)	Run automatically
D1	Base	AM	J10 Otterpool Park AM PEAK	ONE HOUR	07:45	09:15	15	9
D2	Base	PM	J10 Otterpool Park PM PEAK	ONE HOUR	16:45	18:15	15	9

Analysis Set Details

ID	Include in report	Network flow scaling factor (%)	Network capacity scaling factor (%)
A1	9	100.000	100.000

Base, AM

Data Errors and Warnings

No errors or warnings

Junction Network

Junctions

Junction	Name	Junction Type	Major road direction	Junction Delay (s)	Junction LOS
1	untitled	T-Junction	Two-way	3.89	A

Junction Network Options

Driving side	Lighting
Left	Normal/unknown

Arms

Arms

Arm	Name	Description	Arm type
A	Aldington Road Westbound		Major
B	Stone Street		Minor
C	Aldington Road Eastbound		Major

Major Arm Geometry

Arm	Width of carriageway (m)	Has kerbed central reserve	Has right turn bay	Visibility for right turn (m)	Blocks?	Blocking queue (PCU)
C	6.00			113.0	9	1.00

Geometries for Arm C are measured opposite Arm B. Geometries for Arm A (if relevant) are measured opposite Arm D.

Minor Arm Geometry

Arm	Minor arm type	Lane width (m)	Visibility to left (m)	Visibility to right (m)
B	One lane	2.50	15	43

Slope / Intercept / Capacity

Priority Intersection Slopes and Intercepts

Junction	Stream	Intercept (Veh/hr)	Slope for A-B	Slope for A-C	Slope for C-A	Slope for C-B
1	B-A	478	0.087	0.220	0.139	0.315
1	B-C	618	0.095	0.240	-	-
1	C-B	639	0.248	0.248	-	-

The slopes and intercepts shown above do NOT include any corrections or adjustments.

Streams may be combined, in which case capacity will be adjusted.

Values are shown for the first time segment only; they may differ for subsequent time segments.

Traffic Demand

Demand Set Details

ID	Scenario name	Time Period name	Description	Traffic profile type	Start time (HH:mm)	Finish time (HH:mm)	Time segment length (min)	Run automatically
D1	Base	AM	J10 Otterpool Park AM PEAK	ONE HOUR	07:45	09:15	15	9

Vehicle mix varies over turn	Vehicle mix varies over entry	Vehicle mix source	PCU Factor for a HV (PCU)
9	9	HV Percentages	2.00

Demand overview (Traffic)

Arm	Linked arm	Profile type	Use O-D data	Average Demand (Veh/hr)	Scaling Factor (%)
A		ONE HOUR	9	310	100.000
B		ONE HOUR	9	157	100.000
C		ONE HOUR	9	80	100.000

Origin -Destination Data

Demand (Veh/hr)

From	To			
	\$	%	&	
\$	0	169	141	
%	115	0	42	
&	74	6	0	

Vehicle Mix

Heavy Vehicle Percentages

From	To			
	\$	%	&	
\$	0	0	1	
%	0	0	2	
&	0	0	0	

Results

Results Summary for whole modelled period

Stream	Max RFC	Max delay (s)	Max Queue (Veh)	Max LOS	Average Demand (Veh/hr)	Total Junction Arrivals (Veh)
B-AC	0.39	13.28	0.6	B	144	216
C-AB	0.01	6.56	0.0	A	6	8
C-A					68	102
A-B					155	233
A-C					129	194

Main Results for each time segment

07:45 - 08:00

Stream	Total Demand (Veh/hr)	Junction Arrivals (Veh)	Capacity (Veh/hr)	RFC	Throughput (Veh/hr)	Start queue (Veh)	End queue (Veh)	Delay (s)	LOS
B-AC	118	30	464	0.255	117	0.0	0.3	10.334	B
C-AB	5	1	582	0.008	4	0.0	0.0	6.235	A
C-A	56	14			56				
A-B	127	32			127				
A-C	106	27			106				

08:00 - 08:15

Stream	Total Demand (Veh/hr)	Junction Arrivals (Veh)	Capacity (Veh/hr)	RFC	Throughput (Veh/hr)	Start queue (Veh)	End queue (Veh)	Delay (s)	LOS
B-AC	141	35	455	0.310	141	0.3	0.4	11.420	B
C-AB	5	1	571	0.009	5	0.0	0.0	6.367	A
C-A	67	17			67				
A-B	152	38			152				
A-C	127	32			127				

08:15 - 08:30

Stream	Total Demand (Veh/hr)	Junction Arrivals (Veh)	Capacity (Veh/hr)	RFC	Throughput (Veh/hr)	Start queue (Veh)	End queue (Veh)	Delay (s)	LOS
B-AC	173	43	444	0.389	172	0.4	0.6	13.210	B
C-AB	7	2	555	0.012	7	0.0	0.0	6.558	A
C-A	81	20			81				
A-B	186	47			186				
A-C	155	39			155				

08:30 - 08:45

Stream	Total Demand (Veh/hr)	Junction Arrivals (Veh)	Capacity (Veh/hr)	RFC	Throughput (Veh/hr)	Start queue (Veh)	End queue (Veh)	Delay (s)	LOS
B-AC	173	43	444	0.389	173	0.6	0.6	13.277	B
C-AB	7	2	555	0.012	7	0.0	0.0	6.558	A
C-A	81	20			81				
A-B	186	47			186				
A-C	155	39			155				

08:45 - 09:00

Stream	Total Demand (Veh/hr)	Junction Arrivals (Veh)	Capacity (Veh/hr)	RFC	Throughput (Veh/hr)	Start queue (Veh)	End queue (Veh)	Delay (s)	LOS
B-AC	141	35	455	0.310	142	0.6	0.5	11.505	B
C-AB	5	1	571	0.009	5	0.0	0.0	6.368	A
C-A	67	17			67				
A-B	152	38			152				
A-C	127	32			127				

09:00 - 09:15

Stream	Total Demand (Veh/hr)	Junction Arrivals (Veh)	Capacity (Veh/hr)	RFC	Throughput (Veh/hr)	Start queue (Veh)	End queue (Veh)	Delay (s)	LOS
B-AC	118	30	464	0.255	119	0.5	0.3	10.441	B
C-AB	5	1	582	0.008	5	0.0	0.0	6.236	A
C-A	56	14			56				
A-B	127	32			127				
A-C	106	27			106				

Base, PM

Data Errors and Warnings

No errors or warnings

Junction Network

Junctions

Junction	Name	Junction Type	Major road direction	Junction Delay (s)	Junction LOS
1	untitled	T-Junction	Two-way	9.87	A

Junction Network Options

Driving side	Lighting
Left	Normal/unknown

Traffic Demand

Demand Set Details

ID	Scenario name	Time Period name	Description	Traffic profile type	Start time (HH:mm)	Finish time (HH:mm)	Time segment length (min)	Run automatically
D2	Base	PM	J10 Otterpool Park PM PEAK	ONE HOUR	16:45	18:15	15	9

Vehicle mix varies over turn	Vehicle mix varies over entry	Vehicle mix source	PCU Factor for a HV (PCU)
9	9	HV Percentages	2.00

Demand overview (Traffic)

Arm	Linked arm	Profile type	Use O-D data	Average Demand (Veh/hr)	Scaling Factor (%)
A		ONE HOUR	9	137	100.000
B		ONE HOUR	9	254	100.000
C		ONE HOUR	9	140	100.000

Origin -Destination Data

Demand (Veh/hr)

From	To			
	\$	%	&	
\$	0	83	54	
%	204	0	50	
&	127	13	0	

Vehicle Mix

Heavy Vehicle Percentages

From	To			
	\$	%	&	
\$	0	0	0	
%	0	0	2	
&	0	0	0	

Results

Results Summary for whole modelled period

Stream	Max RFC	Max delay (s)	Max Queue (Veh)	Max LOS	Average Demand (Veh/hr)	Total Junction Arrivals (Veh)
B-AC	0.61	20.29	1.5	C	233	350
C-AB	0.02	6.09	0.0	A	12	18
C-A					116	175
A-B					76	114
A-C					50	74

Main Results for each time segment

16:45 - 17:00

Stream	Total Demand (Veh/hr)	Junction Arrivals (Veh)	Capacity (Veh/hr)	RFC	Throughput (Veh/hr)	Start queue (Veh)	End queue (Veh)	Delay (s)	LOS
B-AC	191	48	470	0.407	189	0.0	0.7	12.674	B
C-AB	10	2	615	0.016	10	0.0	0.0	5.944	A
C-A	96	24			96				
A-B	62	16			62				
A-C	41	10			41				

17:00 - 17:15

Stream	Total Demand (Veh/hr)	Junction Arrivals (Veh)	Capacity (Veh/hr)	RFC	Throughput (Veh/hr)	Start queue (Veh)	End queue (Veh)	Delay (s)	LOS
B-AC	228	57	464	0.492	227	0.7	0.9	15.086	C
C-AB	12	3	611	0.019	12	0.0	0.0	6.005	A
C-A	114	29			114				
A-B	75	19			75				
A-C	49	12			49				

17:15 - 17:30

Stream	Total Demand (Veh/hr)	Junction Arrivals (Veh)	Capacity (Veh/hr)	RFC	Throughput (Veh/hr)	Start queue (Veh)	End queue (Veh)	Delay (s)	LOS
B-AC	280	70	457	0.613	277	0.9	1.5	19.837	C
C-AB	14	4	605	0.024	14	0.0	0.0	6.091	A
C-A	140	35			140				
A-B	91	23			91				
A-C	59	15			59				

17:30 - 17:45

Stream	Total Demand (Veh/hr)	Junction Arrivals (Veh)	Capacity (Veh/hr)	RFC	Throughput (Veh/hr)	Start queue (Veh)	End queue (Veh)	Delay (s)	LOS
B-AC	280	70	457	0.613	280	1.5	1.5	20.289	C
C-AB	14	4	605	0.024	14	0.0	0.0	6.091	A
C-A	140	35			140				
A-B	91	23			91				
A-C	59	15			59				

17:45 - 18:00

Stream	Total Demand (Veh/hr)	Junction Arrivals (Veh)	Capacity (Veh/hr)	RFC	Throughput (Veh/hr)	Start queue (Veh)	End queue (Veh)	Delay (s)	LOS
B-AC	228	57	464	0.492	231	1.5	1.0	15.536	C
C-AB	12	3	611	0.019	12	0.0	0.0	6.006	A
C-A	114	29			114				
A-B	75	19			75				
A-C	49	12			49				

18:00 - 18:15

Stream	Total Demand (Veh/hr)	Junction Arrivals (Veh)	Capacity (Veh/hr)	RFC	Throughput (Veh/hr)	Start queue (Veh)	End queue (Veh)	Delay (s)	LOS
B-AC	191	48	470	0.407	192	1.0	0.7	13.023	B
C-AB	10	2	615	0.016	10	0.0	0.0	5.944	A
C-A	96	24			96				
A-B	62	16			62				
A-C	41	10			41				

F.12 J11_A20 Stone Street

Junctions 9
PICADY 9 - Priority Intersection Module
Version: 9.0.2.5947 © Copyright TRL Limited, 2017
For sales and distribution information, program advice and maintenance, contact TRL: +44 (0)1344 770558 software@trl.co.uk www.trlsoftware.co.uk
The users of this computer program for the solution of an engineering problem are in no way relieved of their responsibility for the correctness of the solution

Filename: J11_A20 Stone Street_Base Model.j9

Path: K:\UA008926 Otterpool\D-Calcs\Modelling\DM_it5\Appendix\Appendix Base Models\Picady\J11 A20 Ashford Rd-A261 Hyther Rd

Report generation date: 20/11/2018 15:44:22

»Base, AM

»Base, PM

Summary of junction performance

	AM				PM			
	Queue (Veh)	Delay (s)	RFC	LOS	Queue (Veh)	Delay (s)	RFC	LOS
	Base							
Stream B-C	0.1	15.58	0.12	C	0.0	8.59	0.03	A
Stream B-A	2.5	36.54	0.72	E	0.6	16.48	0.37	C
Stream C-AB	0.0	7.80	0.02	A	0.0	7.77	0.05	A

Values shown are the highest values encountered over all time segments. Delay is the maximum value of average delay per arriving vehicle.

File summary

File Description

Title	J11 Otterpool Park A20-Stone St - Base model
Location	A20 Ashford Rd/ A261 Hythe Rd/Stone St
Site number	
Date	06/07/2017
Version	
Status	
Identifier	
Client	
Jobnumber	
Enumerator	bpa76880 [HCL70028]
Description	

Units

Distance units	Speed units	Traffic units input	Traffic units results	Flow units	Average delay units	Total delay units	Rate of delay units
m	kph	Veh	Veh	perMin	s	-Min	perMin

Analysis Options

Vehicle length (m)	Calculate Queue Percentiles	Calculate detailed queueing delay	Calculate residual capacity	RFC Threshold	Average Delay threshold (s)	Queue threshold (PCU)
5.75				0.85	36.00	20.00

Demand Set Summary

ID	Scenario name	Time Period name	Description	Traffic profile type	Start time (HH:mm)	Finish time (HH:mm)	Time period length (min)	Time segment length (min)	Run automatically
D1	Base	AM	AM 2017 reviewed	DIRECT	08:00	09:00	60	15	9
D2	Base	PM	PM 2017 reviewed	DIRECT	17:00	18:00	60	15	9

Analysis Set Details

ID	Include in report	Network flow scaling factor (%)	Network capacity scaling factor (%)
A1	9	100.000	100.000

Base, AM

Data Errors and Warnings

No errors or warnings

Junction Network

Junctions

Junction	Name	Junction Type	Major road direction	Junction Delay (s)	Junction LOS
1	untitled	T-Junction	Two-way	8.25	A

Junction Network Options

Driving side	Lighting
Left	Normal/unknown

Arms

Arms

Arm	Name	Description	Arm type
A	A20 Westbound		Major
B	Stone Street		Minor
C	A20 Eastbound		Major

Major Arm Geometry

Arm	Width of carriageway (m)	Has kerbed central reserve	Has right turn bay	Width for right turn (m)	Visibility for right turn (m)	Blocks?	Blocking queue (PCU)
C	9.50		9	2.40	125.0	9	3.00

Geometries for Arm C are measured opposite Arm B. Geometries for Arm A (if relevant) are measured opposite Arm D.

Minor Arm Geometry

Arm	Minor arm type	Width at give-way (m)	Width at 5m (m)	Width at 10m (m)	Width at 15m (m)	Width at 20m (m)	Estimate flare length	Flare length (PCU)	Visibility to left (m)	Visibility to right (m)
B	One lane plus flare	10.00	7.49	5.00	3.75	3.07		2.00	32	33

Slope / Intercept / Capacity

Priority Intersection Slopes and Intercepts

Junction	Stream	Intercept (Veh/min)	Slope for A-B	Slope for A-C	Slope for C-A	Slope for C-B
1	B-A	9.460	0.088	0.222	0.139	0.316
1	B-C	10.397	0.081	0.205	-	-
1	C-B	11.007	0.217	0.217	-	-

The slopes and intercepts shown above do NOT include any corrections or adjustments.

Streams may be combined, in which case capacity will be adjusted.

Values are shown for the first time segment only; they may differ for subsequent time segments.

Traffic Demand

Demand Set Details

ID	Scenario name	Time Period name	Description	Traffic profile type	Start time (HH:mm)	Finish time (HH:mm)	Time period length (min)	Time segment length (min)	Run automatically
D1	Base	AM	AM 2017 reviewed	DIRECT	08:00	09:00	60	15	9

Default vehicle mix	Vehicle mix varies over entry	Vehicle mix source	PCU Factor for a HV (PCU)
9	9	HV Percentages	2.00

Demand overview (Traffic)

Arm	Linked arm	Profile type	Use O-D data	Scaling Factor (%)
A		DIRECT		100.000
B		DIRECT		100.000
C		DIRECT		100.000

Origin -Destination Data

Demand (Veh/min)

From	To		
	\$	%	&
\$	0.00	130.00	459.00
%	257.00	0.00	31.00
&	321.00	11.00	0.00

Vehicle Mix

Heavy Vehicle Percentages

From	To		
	\$	%	&
\$	10	10	10
%	10	10	10
&	10	10	10

Results

Results Summary for whole modelled period

Stream	Max RFC	Max delay (s)	Max Queue (Veh)	Max LOS	Average Demand (Veh/min)	Total Junction Arrivals (Veh)
B-C	0.12	15.58	0.1	C	0.52	31.00
B-A	0.72	36.54	2.5	E	4.28	257.00
C-AB	0.02	7.80	0.0	A	0.18	10.93
C-A					5.32	319.07
A-B					2.17	130.04
A-C					7.65	459.16

Main Results for each time segment

08:00 - 08:15

Stream	Total Demand (Veh/min)	Junction Arrivals (Veh)	Capacity (Veh/min)	RFC	Throughput (Veh/min)	Start queue (Veh)	End queue (Veh)	Delay (s)	LOS
B-C	0.52	7.75	4.67	0.111	0.51	0.0	0.1	14.395	B
B-A	4.28	64.25	5.91	0.724	4.13	0.0	2.3	31.429	D
C-AB	0.18	2.73	7.88	0.023	0.18	0.0	0.0	7.794	A
C-A	5.32	79.77			5.32				
A-B	2.17	32.51			2.17				
A-C	7.65	114.79			7.65				

08:15 - 08:30

Stream	Total Demand (Veh/min)	Junction Arrivals (Veh)	Capacity (Veh/min)	RFC	Throughput (Veh/min)	Start queue (Veh)	End queue (Veh)	Delay (s)	LOS
B-C	0.52	7.75	4.39	0.118	0.52	0.1	0.1	15.474	C
B-A	4.28	64.25	5.91	0.724	4.27	2.3	2.5	36.101	E
C-AB	0.18	2.73	7.88	0.023	0.18	0.0	0.0	7.797	A
C-A	5.32	79.77			5.32				
A-B	2.17	32.51			2.17				
A-C	7.65	114.79			7.65				

08:30 - 08:45

Stream	Total Demand (Veh/min)	Junction Arrivals (Veh)	Capacity (Veh/min)	RFC	Throughput (Veh/min)	Start queue (Veh)	End queue (Veh)	Delay (s)	LOS
B-C	0.52	7.75	4.38	0.118	0.52	0.1	0.1	15.548	C
B-A	4.28	64.25	5.91	0.724	4.28	2.5	2.5	36.419	E
C-AB	0.18	2.73	7.88	0.023	0.18	0.0	0.0	7.797	A
C-A	5.32	79.77			5.32				
A-B	2.17	32.51			2.17				
A-C	7.65	114.79			7.65				

08:45 - 09:00

Stream	Total Demand (Veh/min)	Junction Arrivals (Veh)	Capacity (Veh/min)	RFC	Throughput (Veh/min)	Start queue (Veh)	End queue (Veh)	Delay (s)	LOS
B-C	0.52	7.75	4.37	0.118	0.52	0.1	0.1	15.575	C
B-A	4.28	64.25	5.91	0.724	4.28	2.5	2.5	36.540	E
C-AB	0.18	2.73	7.88	0.023	0.18	0.0	0.0	7.797	A
C-A	5.32	79.77			5.32				
A-B	2.17	32.51			2.17				
A-C	7.65	114.79			7.65				

Base, PM

Data Errors and Warnings

No errors or warnings

Junction Network

Junctions

Junction	Name	Junction Type	Major road direction	Junction Delay (s)	Junction LOS
1	untitled	T-Junction	Two-way	1.89	A

Junction Network Options

Driving side	Lighting
Left	Normal/unknown

Traffic Demand

Demand Set Details

ID	Scenario name	Time Period name	Description	Traffic profile type	Start time (HH:mm)	Finish time (HH:mm)	Time period length (min)	Time segment length (min)	Run automatically
D2	Base	PM	PM 2017 reviewed	DIRECT	17:00	18:00	60	15	9

Default vehicle mix	Vehicle mix varies over entry	Vehicle mix source	PCU Factor for a HV (PCU)
9	9	HV Percentages	2.00

Demand overview (Traffic)

Arm	Linked arm	Profile type	Use O-D data	Scaling Factor (%)
A		DIRECT		100.000
B		DIRECT		100.000
C		DIRECT		100.000

Origin -Destination Data

Demand (Veh/min)

		To		
From		\$	%	&
	\$	0.00	247.00	285.00
	%	128.00	0.00	12.00
	&	564.00	22.00	0.00

Vehicle Mix

Heavy Vehicle Percentages

		To		
From		\$	%	&
	\$	10	10	10
	%	10	10	10
	&	10	10	10

Results

Results Summary for whole modelled period

Stream	Max RFC	Max delay (s)	Max Queue (Veh)	Max LOS	Average Demand (Veh/min)	Total Junction Arrivals (Veh)
B-C	0.03	8.59	0.0	A	0.20	11.98
B-A	0.37	16.48	0.6	C	2.13	127.82
C-AB	0.05	7.77	0.0	A	0.37	22.01
C-A					9.40	564.19
A-B					4.12	247.09
A-C					4.75	285.11

Main Results for each time segment

17:00 - 17:15

Stream	Total Demand (Veh/min)	Junction Arrivals (Veh)	Capacity (Veh/min)	RFC	Throughput (Veh/min)	Start queue (Veh)	End queue (Veh)	Delay (s)	LOS
B-C	0.20	3.00	7.21	0.028	0.20	0.0	0.0	8.552	A
B-A	2.13	31.95	5.77	0.369	2.09	0.0	0.6	16.152	C
C-AB	0.37	5.50	8.08	0.045	0.36	0.0	0.0	7.768	A
C-A	9.40	141.05			9.40				
A-B	4.12	61.77			4.12				
A-C	4.75	71.28			4.75				

17:15 - 17:30

Stream	Total Demand (Veh/min)	Junction Arrivals (Veh)	Capacity (Veh/min)	RFC	Throughput (Veh/min)	Start queue (Veh)	End queue (Veh)	Delay (s)	LOS
B-C	0.20	3.00	7.19	0.028	0.20	0.0	0.0	8.585	A
B-A	2.13	31.95	5.77	0.369	2.13	0.6	0.6	16.474	C
C-AB	0.37	5.50	8.08	0.045	0.37	0.0	0.0	7.774	A
C-A	9.40	141.05			9.40				
A-B	4.12	61.77			4.12				
A-C	4.75	71.28			4.75				

17:30 - 17:45

Stream	Total Demand (Veh/min)	Junction Arrivals (Veh)	Capacity (Veh/min)	RFC	Throughput (Veh/min)	Start queue (Veh)	End queue (Veh)	Delay (s)	LOS
B-C	0.20	3.00	7.19	0.028	0.20	0.0	0.0	8.586	A
B-A	2.13	31.95	5.77	0.369	2.13	0.6	0.6	16.479	C
C-AB	0.37	5.50	8.08	0.045	0.37	0.0	0.0	7.774	A
C-A	9.40	141.05			9.40				
A-B	4.12	61.77			4.12				
A-C	4.75	71.28			4.75				

17:45 - 18:00

Stream	Total Demand (Veh/min)	Junction Arrivals (Veh)	Capacity (Veh/min)	RFC	Throughput (Veh/min)	Start queue (Veh)	End queue (Veh)	Delay (s)	LOS
B-C	0.20	3.00	7.19	0.028	0.20	0.0	0.0	8.586	A
B-A	2.13	31.95	5.77	0.369	2.13	0.6	0.6	16.478	C
C-AB	0.37	5.50	8.08	0.045	0.37	0.0	0.0	7.774	A
C-A	9.40	141.05			9.40				
A-B	4.12	61.77			4.12				
A-C	4.75	71.28			4.75				

F.13 J11_A20 Hythe Road

Junctions 9
PICADY 9 - Priority Intersection Module
Version: 9.0.2.5947 © Copyright TRL Limited, 2017
For sales and distribution information, program advice and maintenance, contact TRL: +44 (0)1344 770558 software@trl.co.uk www.trlsoftware.co.uk
The users of this computer program for the solution of an engineering problem are in no way relieved of their responsibility for the correctness of the solution

Filename: J11_A20 Hythe Road_Base Model.j9

Path: K:\UA008926 Otterpool\D-Calcs\Modelling\DM_it5\Appendix\Appendix Base Models\Picady\J11 A20 Ashford Rd-A261 Hyther Rd

Report generation date: 20/11/2018 15:43:25

»Base, AM

»Base, PM

Summary of junction performance

	AM				PM			
	Queue (Veh)	Delay (s)	RFC	LOS	Queue (Veh)	Delay (s)	RFC	LOS
	Base							
Stream B-C	2.5	77.35	0.75	F	0.6	22.15	0.39	C
Stream B-A	5.7	88.64	0.87	F	2.4	49.08	0.72	E
Stream C-AB	0.2	7.92	0.18	A	0.5	10.50	0.35	B

Values shown are the highest values encountered over all time segments. Delay is the maximum value of average delay per arriving vehicle.

File summary

File Description

Title	J11 Otterpool Park_Base Model
Location	A20 Ashford Rd/ A261 Hythe Rd/Stone St
Site number	
Date	07/07/2017
Version	
Status	
Identifier	
Client	
Jobnumber	
Enumerator	bpa76880 [HCL70028]
Description	

Units

Distance units	Speed units	Traffic units input	Traffic units results	Flow units	Average delay units	Total delay units	Rate of delay units
m	kph	Veh	Veh	perMin	s	-Min	perMin

Analysis Options

Vehicle length (m)	Calculate Queue Percentiles	Calculate detailed queueing delay	Calculate residual capacity	RFC Threshold	Average Delay threshold (s)	Queue threshold (PCU)
5.75				0.85	36.00	20.00

Demand Set Summary

ID	Scenario name	Time Period name	Description	Traffic profile type	Start time (HH:mm)	Finish time (HH:mm)	Time period length (min)	Time segment length (min)	Run automatically
D1	Base	AM	AM PEAK 2017 reviewed	DIRECT	08:00	09:00	60	15	9
D2	Base	PM	PM PEAK 2017 reviewed	DIRECT	17:00	18:00	60	15	9

Analysis Set Details

ID	Include in report	Network flow scaling factor (%)	Network capacity scaling factor (%)
A1	9	100.000	100.000

Base, AM

Data Errors and Warnings

No errors or warnings

Junction Network

Junctions

Junction	Name	Junction Type	Major road direction	Junction Delay (s)	Junction LOS
1	untitled	T-Junction	Two-way	20.39	C

Junction Network Options

Driving side	Lighting
Left	Normal/unknown

Arms

Arms

Arm	Name	Description	Arm type
A	A20 Westbound		Major
B	Hythe Road		Minor
C	A20 Eastbound		Major

Major Arm Geometry

Arm	Width of carriageway (m)	Has kerbed central reserve	Has right turn bay	Width for right turn (m)	Visibility for right turn (m)	Blocks?	Blocking queue (PCU)
C	10.62		9	4.30	112.0	9	7.00

Geometries for Arm C are measured opposite Arm B. Geometries for Arm A (if relevant) are measured opposite Arm D.

Minor Arm Geometry

Arm	Minor arm type	Width at give-way (m)	Width at 5m (m)	Width at 10m (m)	Width at 15m (m)	Width at 20m (m)	Estimate flare length	Flare length (PCU)	Visibility to left (m)	Visibility to right (m)
B	One lane plus flare	6.31	5.81	5.17	4.47	3.78		2.00	40	48

Slope / Intercept / Capacity

Priority Intersection Slopes and Intercepts

Junction	Stream	Intercept (Veh/min)	Slope for A-B	Slope for A-C	Slope for C-A	Slope for C-B
1	B-A	9.070	0.079	0.200	0.126	0.286
1	B-C	9.655	0.071	0.179	-	-
1	C-B	13.080	0.243	0.243	-	-

The slopes and intercepts shown above do NOT include any corrections or adjustments.

Streams may be combined, in which case capacity will be adjusted.

Values are shown for the first time segment only; they may differ for subsequent time segments.

Traffic Demand

Demand Set Details

ID	Scenario name	Time Period name	Description	Traffic profile type	Start time (HH:mm)	Finish time (HH:mm)	Time period length (min)	Time segment length (min)	Run automatically
D1	Base	AM	AM PEAK 2017 reviewed	DIRECT	08:00	09:00	60	15	9

Default vehicle mix	Vehicle mix varies over entry	Vehicle mix source	PCU Factor for a HV (PCU)
9	9	HV Percentages	2.00

Demand overview (Traffic)

Arm	Linked arm	Profile type	Use O-D data	Scaling Factor (%)
A		DIRECT		100.000
B		DIRECT		100.000
C		DIRECT		100.000

Origin -Destination Data

Demand (Veh/min)

From	To		
	\$	%	&
\$	0.00	185.00	461.00
%	247.00	0.00	128.00
&	476.00	102.00	0.00

Vehicle Mix

Heavy Vehicle Percentages

From	To		
	\$	%	&
\$	10	10	10
%	10	10	10
&	10	10	10

Results

Results Summary for whole modelled period

Stream	Max RFC	Max delay (s)	Max Queue (Veh)	Max LOS	Average Demand (Veh/min)	Total Junction Arrivals (Veh)
B-C	0.75	77.35	2.5	F	2.13	128.00
B-A	0.87	88.64	5.7	F	4.12	247.00
C-AB	0.18	7.92	0.2	A	1.70	101.97
C-A					7.93	475.83
A-B					3.08	185.06
A-C					7.69	461.14

Main Results for each time segment

08:00 - 08:15

Stream	Total Demand (Veh/min)	Junction Arrivals (Veh)	Capacity (Veh/min)	RFC	Throughput (Veh/min)	Start queue (Veh)	End queue (Veh)	Delay (s)	LOS
B-C	2.13	32.00	3.67	0.581	2.05	0.0	1.3	35.376	E
B-A	4.12	61.75	4.79	0.860	3.85	0.0	4.1	53.933	F
C-AB	1.70	25.49	9.27	0.183	1.68	0.0	0.2	7.890	A
C-A	7.93	118.96			7.93				
A-B	3.08	46.26			3.08				
A-C	7.69	115.29			7.69				

08:15 - 08:30

Stream	Total Demand (Veh/min)	Junction Arrivals (Veh)	Capacity (Veh/min)	RFC	Throughput (Veh/min)	Start queue (Veh)	End queue (Veh)	Delay (s)	LOS
B-C	2.13	32.00	3.07	0.694	2.09	1.3	1.9	58.059	F
B-A	4.12	61.75	4.75	0.867	4.06	4.1	4.9	77.487	F
C-AB	1.70	25.49	9.27	0.183	1.70	0.2	0.2	7.920	A
C-A	7.93	118.96			7.93				
A-B	3.08	46.26			3.08				
A-C	7.69	115.29			7.69				

08:30 - 08:45

Stream	Total Demand (Veh/min)	Junction Arrivals (Veh)	Capacity (Veh/min)	RFC	Throughput (Veh/min)	Start queue (Veh)	End queue (Veh)	Delay (s)	LOS
B-C	2.13	32.00	2.94	0.727	2.11	1.9	2.3	69.486	F
B-A	4.12	61.75	4.73	0.871	4.09	4.9	5.4	84.454	F
C-AB	1.70	25.49	9.27	0.183	1.70	0.2	0.2	7.920	A
C-A	7.93	118.96			7.93				
A-B	3.08	46.26			3.08				
A-C	7.69	115.29			7.69				

08:45 - 09:00

Stream	Total Demand (Veh/min)	Junction Arrivals (Veh)	Capacity (Veh/min)	RFC	Throughput (Veh/min)	Start queue (Veh)	End queue (Veh)	Delay (s)	LOS
B-C	2.13	32.00	2.86	0.747	2.12	2.3	2.5	77.353	F
B-A	4.12	61.75	4.71	0.873	4.10	5.4	5.7	88.639	F
C-AB	1.70	25.49	9.27	0.183	1.70	0.2	0.2	7.920	A
C-A	7.93	118.96			7.93				
A-B	3.08	46.26			3.08				
A-C	7.69	115.29			7.69				

Base, PM

Data Errors and Warnings

No errors or warnings

Junction Network

Junctions

Junction	Name	Junction Type	Major road direction	Junction Delay (s)	Junction LOS
1	untitled	T-Junction	Two-way	7.65	A

Junction Network Options

Driving side	Lighting
Left	Normal/unknown

Traffic Demand

Demand Set Details

ID	Scenario name	Time Period name	Description	Traffic profile type	Start time (HH:mm)	Finish time (HH:mm)	Time period length (min)	Time segment length (min)	Run automatically
D2	Base	PM	PM PEAK 2017 reviewed	DIRECT	17:00	18:00	60	15	9

Default vehicle mix	Vehicle mix varies over entry	Vehicle mix source	PCU Factor for a HV (PCU)
9	9	HV Percentages	2.00

Demand overview (Traffic)

Arm	Linked arm	Profile type	Use O-D data	Scaling Factor (%)
A		DIRECT		100.000
B		DIRECT		100.000
C		DIRECT		100.000

Origin -Destination Data

Demand (Veh/min)

From	To		
	\$	%	&
\$	0.00	338.00	428.00
%	186.00	0.00	104.00
&	507.00	185.00	0.00

Vehicle Mix

Heavy Vehicle Percentages

From	To		
	\$	%	&
\$	10	10	10
%	10	10	10
&	10	10	10

Results

Results Summary for whole modelled period

Stream	Max RFC	Max delay (s)	Max Queue (Veh)	Max LOS	Average Demand (Veh/min)	Total Junction Arrivals (Veh)
B-C	0.39	22.15	0.6	C	1.73	103.93
B-A	0.72	49.08	2.4	E	3.10	185.87
C-AB	0.35	10.50	0.5	B	3.09	185.17
C-A					8.44	506.63
A-B					5.63	338.09
A-C					7.14	428.11

Main Results for each time segment

17:00 - 17:15

Stream	Total Demand (Veh/min)	Junction Arrivals (Veh)	Capacity (Veh/min)	RFC	Throughput (Veh/min)	Start queue (Veh)	End queue (Veh)	Delay (s)	LOS
B-C	1.73	25.98	4.75	0.365	1.70	0.0	0.6	19.427	C
B-A	3.10	46.47	4.31	0.718	2.95	0.0	2.2	40.720	E
C-AB	3.09	46.29	8.80	0.351	3.05	0.0	0.5	10.376	B
C-A	8.44	126.66			8.44				
A-B	5.63	84.52			5.63				
A-C	7.14	107.03			7.14				

17:15 - 17:30

Stream	Total Demand (Veh/min)	Junction Arrivals (Veh)	Capacity (Veh/min)	RFC	Throughput (Veh/min)	Start queue (Veh)	End queue (Veh)	Delay (s)	LOS
B-C	1.73	25.98	4.47	0.387	1.73	0.6	0.6	21.838	C
B-A	3.10	46.47	4.31	0.719	3.09	2.2	2.3	48.153	E
C-AB	3.09	46.29	8.80	0.351	3.09	0.5	0.5	10.499	B
C-A	8.44	126.66			8.44				
A-B	5.63	84.52			5.63				
A-C	7.14	107.03			7.14				

17:30 - 17:45

Stream	Total Demand (Veh/min)	Junction Arrivals (Veh)	Capacity (Veh/min)	RFC	Throughput (Veh/min)	Start queue (Veh)	End queue (Veh)	Delay (s)	LOS
B-C	1.73	25.98	4.45	0.389	1.73	0.6	0.6	22.069	C
B-A	3.10	46.47	4.31	0.720	3.09	2.3	2.4	48.828	E
C-AB	3.09	46.29	8.80	0.351	3.09	0.5	0.5	10.501	B
C-A	8.44	126.66			8.44				
A-B	5.63	84.52			5.63				
A-C	7.14	107.03			7.14				

17:45 - 18:00

Stream	Total Demand (Veh/min)	Junction Arrivals (Veh)	Capacity (Veh/min)	RFC	Throughput (Veh/min)	Start queue (Veh)	End queue (Veh)	Delay (s)	LOS
B-C	1.73	25.98	4.44	0.390	1.73	0.6	0.6	22.151	C
B-A	3.10	46.47	4.31	0.720	3.10	2.4	2.4	49.084	E
C-AB	3.09	46.29	8.80	0.351	3.09	0.5	0.5	10.501	B
C-A	8.44	126.66			8.44				
A-B	5.63	84.52			5.63				
A-C	7.14	107.03			7.14				

F.14 J12_Aldington Rd Lympne Hill

Junctions 9
PICADY 9 - Priority Intersection Module
Version: 9.0.2.5947 © Copyright TRL Limited, 2017
For sales and distribution information, program advice and maintenance, contact TRL: +44 (0)1344 770558 software@trl.co.uk www.trlsoftware.co.uk
The users of this computer program for the solution of an engineering problem are in no way relieved of their responsibility for the correctness of the solution

Filename: J12_Aldington Rd Lypne Hill_Base Model.j9

Path: K:\UA008926 Otterpool\D-Calcs\Modelling\DM_it5\Appendix\Appendix Base Models\Picady\J12 Aldington Rd - Lypne Hill

Report generation date: 20/11/2018 15:45:32

»Base, AM

»Base, PM

Summary of junction performance

	AM				PM			
	Queue (Veh)	Delay (s)	RFC	LOS	Queue (Veh)	Delay (s)	RFC	LOS
	Base							
Stream B-AC	0.9	12.08	0.47	B	0.2	7.63	0.17	A
Stream C-AB	0.3	7.12	0.22	A	0.9	10.58	0.47	B

Values shown are the highest values encountered over all time segments. Delay is the maximum value of average delay per arriving vehicle.

File summary

File Description

Title	J12 Otterpool Park_Base Model
Location	Aldington Rd - Lypne Hill
Site number	
Date	09/08/2017
Version	
Status	Base
Identifier	
Client	
Jobnumber	
Enumerator	dma78191 [C8Z9W0G2]
Description	

Units

Distance units	Speed units	Traffic units input	Traffic units results	Flow units	Average delay units	Total delay units	Rate of delay units
m	kph	Veh	Veh	perHour	s	-Hour	perHour

Analysis Options

Vehicle length (m)	Calculate Queue Percentiles	Calculate detailed queueing delay	Calculate residual capacity	RFC Threshold	Average Delay threshold (s)	Queue threshold (PCU)
5.75				0.85	36.00	20.00

Demand Set Summary

ID	Scenario name	Time Period name	Description	Traffic profile type	Start time (HH:mm)	Finish time (HH:mm)	Time segment length (min)	Run automatically
D1	Base	AM	J12 Otterpool Park AM PEAK	ONE HOUR	07:45	09:15	15	9
D2	Base	PM	J12 Otterpool Park PM PEAK	ONE HOUR	16:45	18:15	15	9

Analysis Set Details

ID	Include in report	Network flow scaling factor (%)	Network capacity scaling factor (%)
A1	9	100.000	100.000

Base, AM

Data Errors and Warnings

No errors or warnings

Junction Network

Junctions

Junction	Name	Junction Type	Major road direction	Junction Delay (s)	Junction LOS
1	untitled	T-Junction	Two-way	8.10	A

Junction Network Options

Driving side	Lighting
Left	Normal/unknown

Arms

Arms

Arm	Name	Description	Arm type
A	Aldington Road Westbound		Major
B	Lympne Hill		Minor
C	Aldington Road Eastbound		Major

Major Arm Geometry

Arm	Width of carriageway (m)	Has kerbed central reserve	Has right turn bay	Visibility for right turn (m)	Blocks?	Blocking queue (PCU)
C	6.00			59.0	9	0.00

Geometries for Arm C are measured opposite Arm B. Geometries for Arm A (if relevant) are measured opposite Arm D.

Minor Arm Geometry

Arm	Minor arm type	Lane width (m)	Visibility to left (m)	Visibility to right (m)
B	One lane	2.20	34	32

Slope / Intercept / Capacity

Priority Intersection Slopes and Intercepts

Junction	Stream	Intercept (Veh/hr)	Slope for A-B	Slope for A-C	Slope for C-A	Slope for C-B
1	B-A	464	0.085	0.214	0.134	0.305
1	B-C	592	0.091	0.230	-	-
1	C-B	608	0.236	0.236	-	-

The slopes and intercepts shown above do NOT include any corrections or adjustments.

Streams may be combined, in which case capacity will be adjusted.

Values are shown for the first time segment only; they may differ for subsequent time segments.

Traffic Demand

Demand Set Details

ID	Scenario name	Time Period name	Description	Traffic profile type	Start time (HH:mm)	Finish time (HH:mm)	Time segment length (min)	Run automatically
D1	Base	AM	J12 Otterpool Park AM PEAK	ONE HOUR	07:45	09:15	15	9

Vehicle mix varies over turn	Vehicle mix varies over entry	Vehicle mix source	PCU Factor for a HV (PCU)
9	9	HV Percentages	2.00

Demand overview (Traffic)

Arm	Linked arm	Profile type	Use O-D data	Average Demand (Veh/hr)	Scaling Factor (%)
A		ONE HOUR	9	46	100.000
B		ONE HOUR	9	241	100.000
C		ONE HOUR	9	182	100.000

Origin -Destination Data

Demand (Veh/hr)

From	To			
	\$	%	&	
\$	0	4	42	
%	11	0	230	
&	69	113	0	

Vehicle Mix

Heavy Vehicle Percentages

From	To			
	\$	%	&	
\$	0	25	2	
%	18	0	0	
&	0	0	0	

Results

Results Summary for whole modelled period

Stream	Max RFC	Max delay (s)	Max Queue (Veh)	Max LOS	Average Demand (Veh/hr)	Total Junction Arrivals (Veh)
B-AC	0.47	12.08	0.9	B	221	332
C-AB	0.22	7.12	0.3	A	115	173
C-A					52	77
A-B					4	6
A-C					39	58

Main Results for each time segment

07:45 - 08:00

Stream	Total Demand (Veh/hr)	Junction Arrivals (Veh)	Capacity (Veh/hr)	RFC	Throughput (Veh/hr)	Start queue (Veh)	End queue (Veh)	Delay (s)	LOS
B-AC	181	45	568	0.319	180	0.0	0.5	9.216	A
C-AB	93	23	634	0.146	92	0.0	0.2	6.630	A
C-A	44	11			44				
A-B	3	0.75			3				
A-C	32	8			32				

08:00 - 08:15

Stream	Total Demand (Veh/hr)	Junction Arrivals (Veh)	Capacity (Veh/hr)	RFC	Throughput (Veh/hr)	Start queue (Veh)	End queue (Veh)	Delay (s)	LOS
B-AC	217	54	566	0.383	216	0.5	0.6	10.261	B
C-AB	113	28	639	0.176	112	0.2	0.2	6.829	A
C-A	51	13			51				
A-B	4	1			4				
A-C	38	9			38				

08:15 - 08:30

Stream	Total Demand (Veh/hr)	Junction Arrivals (Veh)	Capacity (Veh/hr)	RFC	Throughput (Veh/hr)	Start queue (Veh)	End queue (Veh)	Delay (s)	LOS
B-AC	265	66	563	0.471	264	0.6	0.9	11.995	B
C-AB	141	35	647	0.218	141	0.2	0.3	7.117	A
C-A	59	15			59				
A-B	4	1			4				
A-C	46	12			46				

08:30 - 08:45

Stream	Total Demand (Veh/hr)	Junction Arrivals (Veh)	Capacity (Veh/hr)	RFC	Throughput (Veh/hr)	Start queue (Veh)	End queue (Veh)	Delay (s)	LOS
B-AC	265	66	563	0.471	265	0.9	0.9	12.075	B
C-AB	141	35	647	0.218	141	0.3	0.3	7.123	A
C-A	59	15			59				
A-B	4	1			4				
A-C	46	12			46				

08:45 - 09:00

Stream	Total Demand (Veh/hr)	Junction Arrivals (Veh)	Capacity (Veh/hr)	RFC	Throughput (Veh/hr)	Start queue (Veh)	End queue (Veh)	Delay (s)	LOS
B-AC	217	54	566	0.383	218	0.9	0.6	10.355	B
C-AB	113	28	640	0.176	113	0.3	0.2	6.841	A
C-A	51	13			51				
A-B	4	1			4				
A-C	38	9			38				

09:00 - 09:15

Stream	Total Demand (Veh/hr)	Junction Arrivals (Veh)	Capacity (Veh/hr)	RFC	Throughput (Veh/hr)	Start queue (Veh)	End queue (Veh)	Delay (s)	LOS
B-AC	181	45	568	0.319	182	0.6	0.5	9.332	A
C-AB	93	23	634	0.146	93	0.2	0.2	6.654	A
C-A	44	11			44				
A-B	3	0.75			3				
A-C	32	8			32				

Base, PM

Data Errors and Warnings

No errors or warnings

Junction Network

Junctions

Junction	Name	Junction Type	Major road direction	Junction Delay (s)	Junction LOS
1	untitled	T-Junction	Two-way	8.11	A

Junction Network Options

Driving side	Lighting
Left	Normal/unknown

Traffic Demand

Demand Set Details

ID	Scenario name	Time Period name	Description	Traffic profile type	Start time (HH:mm)	Finish time (HH:mm)	Time segment length (min)	Run automatically
D2	Base	PM	J12 Otterpool Park PM PEAK	ONE HOUR	16:45	18:15	15	9

Vehicle mix varies over turn	Vehicle mix varies over entry	Vehicle mix source	PCU Factor for a HV (PCU)
9	9	HV Percentages	2.00

Demand overview (Traffic)

Arm	Linked arm	Profile type	Use O-D data	Average Demand (Veh/hr)	Scaling Factor (%)
A		ONE HOUR	9	40	100.000
B		ONE HOUR	9	89	100.000
C		ONE HOUR	9	309	100.000

Origin -Destination Data

Demand (Veh/hr)

		To			
From		\$	%	&	
		0	5	35	
		2	0	87	
		63	246	0	

Vehicle Mix

Heavy Vehicle Percentages

		To			
From		\$	%	&	
		0	0	0	
		0	0	1	
		0	0	0	

Results

Results Summary for whole modelled period

Stream	Max RFC	Max delay (s)	Max Queue (Veh)	Max LOS	Average Demand (Veh/hr)	Total Junction Arrivals (Veh)
B-AC	0.17	7.63	0.2	A	82	123
C-AB	0.47	10.58	0.9	B	249	374
C-A					34	52
A-B					5	7
A-C					32	48

Main Results for each time segment

16:45 - 17:00

Stream	Total Demand (Veh/hr)	Junction Arrivals (Veh)	Capacity (Veh/hr)	RFC	Throughput (Veh/hr)	Start queue (Veh)	End queue (Veh)	Delay (s)	LOS
B-AC	67	17	574	0.117	66	0.0	0.1	7.082	A
C-AB	200	50	633	0.316	198	0.0	0.5	8.256	A
C-A	32	8			32				
A-B	4	0.94			4				
A-C	26	7			26				

17:00 - 17:15

Stream	Total Demand (Veh/hr)	Junction Arrivals (Veh)	Capacity (Veh/hr)	RFC	Throughput (Veh/hr)	Start queue (Veh)	End queue (Veh)	Delay (s)	LOS
B-AC	80	20	572	0.140	80	0.1	0.2	7.307	A
C-AB	243	61	638	0.381	242	0.5	0.6	9.098	A
C-A	35	9			35				
A-B	4	1			4				
A-C	31	8			31				

17:15 - 17:30

Stream	Total Demand (Veh/hr)	Junction Arrivals (Veh)	Capacity (Veh/hr)	RFC	Throughput (Veh/hr)	Start queue (Veh)	End queue (Veh)	Delay (s)	LOS
B-AC	98	24	570	0.172	98	0.2	0.2	7.627	A
C-AB	304	76	644	0.472	303	0.6	0.9	10.517	B
C-A	36	9			36				
A-B	6	1			6				
A-C	39	10			39				

17:30 - 17:45

Stream	Total Demand (Veh/hr)	Junction Arrivals (Veh)	Capacity (Veh/hr)	RFC	Throughput (Veh/hr)	Start queue (Veh)	End queue (Veh)	Delay (s)	LOS
B-AC	98	24	570	0.172	98	0.2	0.2	7.629	A
C-AB	304	76	644	0.472	304	0.9	0.9	10.585	B
C-A	36	9			36				
A-B	6	1			6				
A-C	39	10			39				

17:45 - 18:00

Stream	Total Demand (Veh/hr)	Junction Arrivals (Veh)	Capacity (Veh/hr)	RFC	Throughput (Veh/hr)	Start queue (Veh)	End queue (Veh)	Delay (s)	LOS
B-AC	80	20	572	0.140	80	0.2	0.2	7.315	A
C-AB	243	61	638	0.381	244	0.9	0.7	9.181	A
C-A	35	9			35				
A-B	4	1			4				
A-C	31	8			31				

18:00 - 18:15

Stream	Total Demand (Veh/hr)	Junction Arrivals (Veh)	Capacity (Veh/hr)	RFC	Throughput (Veh/hr)	Start queue (Veh)	End queue (Veh)	Delay (s)	LOS
B-AC	67	17	574	0.117	67	0.2	0.1	7.100	A
C-AB	200	50	633	0.317	201	0.7	0.5	8.356	A
C-A	32	8			32				
A-B	4	0.94			4				
A-C	26	7			26				

F.15 J13_A261 Hythe Rd Aldington Rd

Junctions 9
PICADY 9 - Priority Intersection Module
Version: 9.0.2.5947 © Copyright TRL Limited, 2017
For sales and distribution information, program advice and maintenance, contact TRL: +44 (0)1344 770558 software@trl.co.uk www.trlsoftware.co.uk
The users of this computer program for the solution of an engineering problem are in no way relieved of their responsibility for the correctness of the solution

Filename: J13_A261 Hythe Rd Aldington Rd_Base.j9
Path: K:\UA008926 Otterpool\F-Reports\Transport\1804 Transport Assessment\APPS\APP F - Baseline modelling outputs\Appendix Base Models\Picady\J13 A261 Hythe Rd - Aldington Rd
Report generation date: 28/11/2018 16:32:31

- »Base, AM
- »Base, PM

Summary of junction performance

	AM				PM			
	Queue (Veh)	Delay (s)	RFC	LOS	Queue (Veh)	Delay (s)	RFC	LOS
	Base							
Stream B-AC	0.7	17.04	0.42	C	0.5	14.40	0.32	B
Stream C-AB	0.1	5.65	0.04	A	0.2	4.70	0.09	A

Values shown are the highest values encountered over all time segments. Delay is the maximum value of average delay per arriving vehicle.

File summary

File Description

Title	J13 Otterpool Park_Base Model
Location	A261 Hythe Road / Aldington Road
Site number	
Date	02/11/2017
Version	
Status	
Identifier	
Client	
Jobnumber	
Enumerator	dma78191 [C8Z9W0G2]
Description	

Units

Distance units	Speed units	Traffic units input	Traffic units results	Flow units	Average delay units	Total delay units	Rate of delay units
m	kph	Veh	Veh	perHour	s	-Hour	perHour

Analysis Options

Vehicle length (m)	Calculate Queue Percentiles	Calculate detailed queueing delay	Calculate residual capacity	RFC Threshold	Average Delay threshold (s)	Queue threshold (PCU)
5.75				0.85	36.00	20.00

Demand Set Summary

ID	Scenario name	Time Period name	Description	Traffic profile type	Start time (HH:mm)	Finish time (HH:mm)	Time segment length (min)	Run automatically
D1	Base	AM	J13 Otterpool Park_AM PEAK	ONE HOUR	07:45	09:15	15	9
D2	Base	PM	J13 Otterpool Park_PM PEAK	ONE HOUR	16:45	18:15	15	9

Analysis Set Details

ID	Include in report	Network flow scaling factor (%)	Network capacity scaling factor (%)
A1	9	100.000	100.000

Base, AM

Data Errors and Warnings

No errors or warnings

Junction Network

Junctions

Junction	Name	Junction Type	Major road direction	Junction Delay (s)	Junction LOS
1	untitled	T-Junction	Two-way	2.86	A

Junction Network Options

Driving side	Lighting
Left	Normal/unknown

Arms

Arms

Arm	Name	Description	Arm type
A	Hythe Road WB		Major
B	Aldington Rd		Minor
C	Hythe Road EB		Major

Major Arm Geometry

Arm	Width of carriageway (m)	Has kerbed central reserve	Has right turn bay	Visibility for right turn (m)	Blocks?	Blocking queue (PCU)
C	7.92			100.0	9	0.00

Geometries for Arm C are measured opposite Arm B. Geometries for Arm A (if relevant) are measured opposite Arm D.

Minor Arm Geometry

Arm	Minor arm type	Lane width (m)	Visibility to left (m)	Visibility to right (m)
B	One lane	2.20	86	84

Slope / Intercept / Capacity

Priority Intersection Slopes and Intercepts

Junction	Stream	Intercept (Veh/hr)	Slope for A-B	Slope for A-C	Slope for C-A	Slope for C-B
1	B-A	504	0.084	0.213	0.134	0.304
1	B-C	623	0.087	0.221	-	-
1	C-B	632	0.224	0.224	-	-

The slopes and intercepts shown above do NOT include any corrections or adjustments.

Streams may be combined, in which case capacity will be adjusted.

Values are shown for the first time segment only; they may differ for subsequent time segments.

Traffic Demand

Demand Set Details

ID	Scenario name	Time Period name	Description	Traffic profile type	Start time (HH:mm)	Finish time (HH:mm)	Time segment length (min)	Run automatically
D1	Base	AM	J13 Otterpool Park_AM PEAK	ONE HOUR	07:45	09:15	15	9

Vehicle mix varies over turn	Vehicle mix varies over entry	Vehicle mix source	PCU Factor for a HV (PCU)
9	9	HV Percentages	2.00

Demand overview (Traffic)

Arm	Linked arm	Profile type	Use O-D data	Average Demand (Veh/hr)	Scaling Factor (%)
A		ONE HOUR	9	425	100.000
B		ONE HOUR	9	138	100.000
C		ONE HOUR	9	287	100.000

Origin -Destination Data

Demand (Veh/hr)

From	To			
	\$	%	&	
\$	0	64	361	
%	124	0	14	
&	273	14	0	

Vehicle Mix

Heavy Vehicle Percentages

From	To			
	\$	%	&	
\$	0	4	4	
%	1	0	24	
&	9	9	0	

Results

Results Summary for whole modelled period

Stream	Max RFC	Max delay (s)	Max Queue (Veh)	Max LOS	Average Demand (Veh/hr)	Total Junction Arrivals (Veh)
B-AC	0.42	17.04	0.7	C	127	190
C-AB	0.04	5.65	0.1	A	21	31
C-A					242	364
A-B					59	88
A-C					331	497

Main Results for each time segment

07:45 - 08:00

Stream	Total Demand (Veh/hr)	Junction Arrivals (Veh)	Capacity (Veh/hr)	RFC	Throughput (Veh/hr)	Start queue (Veh)	End queue (Veh)	Delay (s)	LOS
B-AC	104	26	406	0.256	103	0.0	0.3	11.800	B
C-AB	15	4	653	0.024	15	0.0	0.0	5.644	A
C-A	201	50			201				
A-B	48	12			48				
A-C	272	68			272				

08:00 - 08:15

Stream	Total Demand (Veh/hr)	Junction Arrivals (Veh)	Capacity (Veh/hr)	RFC	Throughput (Veh/hr)	Start queue (Veh)	End queue (Veh)	Delay (s)	LOS
B-AC	124	31	388	0.320	124	0.3	0.5	13.578	B
C-AB	20	5	669	0.030	20	0.0	0.0	5.542	A
C-A	238	60			238				
A-B	58	14			58				
A-C	325	81			325				

08:15 - 08:30

Stream	Total Demand (Veh/hr)	Junction Arrivals (Veh)	Capacity (Veh/hr)	RFC	Throughput (Veh/hr)	Start queue (Veh)	End queue (Veh)	Delay (s)	LOS
B-AC	152	38	363	0.419	151	0.5	0.7	16.898	C
C-AB	27	7	693	0.039	27	0.0	0.1	5.408	A
C-A	289	72			289				
A-B	70	18			70				
A-C	397	99			397				

08:30 - 08:45

Stream	Total Demand (Veh/hr)	Junction Arrivals (Veh)	Capacity (Veh/hr)	RFC	Throughput (Veh/hr)	Start queue (Veh)	End queue (Veh)	Delay (s)	LOS
B-AC	152	38	363	0.419	152	0.7	0.7	17.043	C
C-AB	27	7	693	0.039	27	0.1	0.1	5.409	A
C-A	289	72			289				
A-B	70	18			70				
A-C	397	99			397				

08:45 - 09:00

Stream	Total Demand (Veh/hr)	Junction Arrivals (Veh)	Capacity (Veh/hr)	RFC	Throughput (Veh/hr)	Start queue (Veh)	End queue (Veh)	Delay (s)	LOS
B-AC	124	31	388	0.320	125	0.7	0.5	13.728	B
C-AB	20	5	669	0.030	20	0.1	0.0	5.546	A
C-A	238	60			238				
A-B	58	14			58				
A-C	325	81			325				

09:00 - 09:15

Stream	Total Demand (Veh/hr)	Junction Arrivals (Veh)	Capacity (Veh/hr)	RFC	Throughput (Veh/hr)	Start queue (Veh)	End queue (Veh)	Delay (s)	LOS
B-AC	104	26	406	0.256	104	0.5	0.3	11.945	B
C-AB	15	4	653	0.024	15	0.0	0.0	5.645	A
C-A	201	50			201				
A-B	48	12			48				
A-C	272	68			272				

Base, PM

Data Errors and Warnings

No errors or warnings

Junction Network

Junctions

Junction	Name	Junction Type	Major road direction	Junction Delay (s)	Junction LOS
1	untitled	T-Junction	Two-way	1.88	A

Junction Network Options

Driving side	Lighting
Left	Normal/unknown

Traffic Demand

Demand Set Details

ID	Scenario name	Time Period name	Description	Traffic profile type	Start time (HH:mm)	Finish time (HH:mm)	Time segment length (min)	Run automatically
D2	Base	PM	J13 Otterpool Park_PM PEAK	ONE HOUR	16:45	18:15	15	9

Vehicle mix varies over turn	Vehicle mix varies over entry	Vehicle mix source	PCU Factor for a HV (PCU)
9	9	HV Percentages	2.00

Demand overview (Traffic)

Arm	Linked arm	Profile type	Use O-D data	Average Demand (Veh/hr)	Scaling Factor (%)
A		ONE HOUR	9	363	100.000
B		ONE HOUR	9	106	100.000
C		ONE HOUR	9	504	100.000

Origin -Destination Data

Demand (Veh/hr)

	To			
		\$	%	&
From	\$	0	91	272
	%	87	0	19
	&	474	30	0

Vehicle Mix

Heavy Vehicle Percentages

	To			
		\$	%	&
From	\$	0	3	3
	%	0	0	14
	&	1	1	0

Results

Results Summary for whole modelled period

Stream	Max RFC	Max delay (s)	Max Queue (Veh)	Max LOS	Average Demand (Veh/hr)	Total Junction Arrivals (Veh)
B-AC	0.32	14.40	0.5	B	97	146
C-AB	0.09	4.70	0.2	A	58	87
C-A					404	607
A-B					84	125
A-C					250	374

Main Results for each time segment

16:45 - 17:00

Stream	Total Demand (Veh/hr)	Junction Arrivals (Veh)	Capacity (Veh/hr)	RFC	Throughput (Veh/hr)	Start queue (Veh)	End queue (Veh)	Delay (s)	LOS
B-AC	80	20	413	0.193	79	0.0	0.2	10.742	B
C-AB	40	10	807	0.050	40	0.0	0.1	4.693	A
C-A	339	85			339				
A-B	69	17			69				
A-C	205	51			205				

17:00 - 17:15

Stream	Total Demand (Veh/hr)	Junction Arrivals (Veh)	Capacity (Veh/hr)	RFC	Throughput (Veh/hr)	Start queue (Veh)	End queue (Veh)	Delay (s)	LOS
B-AC	95	24	394	0.242	95	0.2	0.3	12.039	B
C-AB	55	14	845	0.065	54	0.1	0.1	4.551	A
C-A	399	100			399				
A-B	82	20			82				
A-C	245	61			245				

17:15 - 17:30

Stream	Total Demand (Veh/hr)	Junction Arrivals (Veh)	Capacity (Veh/hr)	RFC	Throughput (Veh/hr)	Start queue (Veh)	End queue (Veh)	Delay (s)	LOS
B-AC	117	29	367	0.318	116	0.3	0.5	14.335	B
C-AB	79	20	900	0.088	79	0.1	0.2	4.386	A
C-A	476	119			476				
A-B	100	25			100				
A-C	299	75			299				

17:30 - 17:45

Stream	Total Demand (Veh/hr)	Junction Arrivals (Veh)	Capacity (Veh/hr)	RFC	Throughput (Veh/hr)	Start queue (Veh)	End queue (Veh)	Delay (s)	LOS
B-AC	117	29	367	0.318	117	0.5	0.5	14.399	B
C-AB	79	20	900	0.088	79	0.2	0.2	4.388	A
C-A	476	119			476				
A-B	100	25			100				
A-C	299	75			299				

17:45 - 18:00

Stream	Total Demand (Veh/hr)	Junction Arrivals (Veh)	Capacity (Veh/hr)	RFC	Throughput (Veh/hr)	Start queue (Veh)	End queue (Veh)	Delay (s)	LOS
B-AC	95	24	394	0.242	96	0.5	0.3	12.112	B
C-AB	55	14	846	0.065	55	0.2	0.1	4.555	A
C-A	398	100			398				
A-B	82	20			82				
A-C	245	61			245				

18:00 - 18:15

Stream	Total Demand (Veh/hr)	Junction Arrivals (Veh)	Capacity (Veh/hr)	RFC	Throughput (Veh/hr)	Start queue (Veh)	End queue (Veh)	Delay (s)	LOS
B-AC	80	20	413	0.193	80	0.3	0.2	10.828	B
C-AB	41	10	807	0.050	41	0.1	0.1	4.697	A
C-A	339	85			339				
A-B	69	17			69				
A-C	205	51			205				

F.16 J14_A261 London Rd Barrack Hill

<h1>Junctions 9</h1>
<h2>PICADY 9 - Priority Intersection Module</h2>
Version: 9.0.2.5947 © Copyright TRL Limited, 2017
For sales and distribution information, program advice and maintenance, contact TRL: +44 (0)1344 770558 software@trl.co.uk www.trlsoftware.co.uk
The users of this computer program for the solution of an engineering problem are in no way relieved of their responsibility for the correctness of the solution

Filename: J14_A261 London Rd Barrack Hill_Base Model.j9

Path: K:\UA008926 Otterpool\D-Calcs\Modelling\DM_it5\Appendix\Appendix Base Models\Picady\J14 A261 London Rd - Barrack Hill

Report generation date: 20/11/2018 15:48:16

»Base, AM

»Base, PM

Summary of junction performance

	AM				PM			
	Queue (Veh)	Delay (s)	RFC	LOS	Queue (Veh)	Delay (s)	RFC	LOS
	Base							
Stream B-AC	0.7	11.73	0.43	B	0.5	10.06	0.31	B
Stream C-AB	0.6	9.45	0.37	A	0.3	8.82	0.23	A

Values shown are the highest values encountered over all time segments. Delay is the maximum value of average delay per arriving vehicle.

File summary

File Description

Title	J14 Otterpool Park_Base Model
Location	A261 London Rd - Barrack Hill
Site number	
Date	08/08/2017
Version	
Status	Base
Identifier	
Client	
Jobnumber	
Enumerator	dma78191 [C8Z9W0G2]
Description	

Units

Distance units	Speed units	Traffic units input	Traffic units results	Flow units	Average delay units	Total delay units	Rate of delay units
m	kph	Veh	Veh	perHour	s	-Hour	perHour

Analysis Options

Vehicle length (m)	Calculate Queue Percentiles	Calculate detailed queueing delay	Calculate residual capacity	RFC Threshold	Average Delay threshold (s)	Queue threshold (PCU)
5.75				0.85	36.00	20.00

Demand Set Summary

ID	Scenario name	Time Period name	Description	Traffic profile type	Start time (HH:mm)	Finish time (HH:mm)	Time segment length (min)	Run automatically
D1	Base	AM	J14 Otterpool Park AM PEAK	ONE HOUR	07:45	09:15	15	9
D2	Base	PM	J14 Otterpool Park PM PEAK	ONE HOUR	16:45	18:15	15	9

Analysis Set Details

ID	Include in report	Network flow scaling factor (%)	Network capacity scaling factor (%)
A1	9	100.000	100.000

Base, AM

Data Errors and Warnings

No errors or warnings

Junction Network

Junctions

Junction	Name	Junction Type	Major road direction	Junction Delay (s)	Junction LOS
1	untitled	T-Junction	Two-way	3.53	A

Junction Network Options

Driving side	Lighting
Left	Normal/unknown

Arms

Arms

Arm	Name	Description	Arm type
A	A261 London Road Eastbound		Major
B	Barrack Hill		Minor
C	A261 London Road Westbound		Major

Major Arm Geometry

Arm	Width of carriageway (m)	Has kerbed central reserve	Width of kerbed central reserve (m)	Has right turn bay	Width for right turn (m)	Visibility for right turn (m)	Blocks?	Blocking queue (PCU)
C	7.60	9	2.70	9	2.70	85.0	9	2.00

Geometries for Arm C are measured opposite Arm B. Geometries for Arm A (if relevant) are measured opposite Arm D.

Minor Arm Geometry

Arm	Minor arm type	Lane width (m)	Visibility to left (m)	Visibility to right (m)
B	One lane	3.50	75	80

Slope / Intercept / Capacity

Priority Intersection Slopes and Intercepts

Junction	Stream	Intercept (Veh/hr)	Slope for A-B	Slope for A-C	Slope for C-A	Slope for C-B
1	B-A	603	0.096	0.244	0.153	0.348
1	B-C	708	0.101	0.255	-	-
1	C-B	657	0.237	0.237	-	-

The slopes and intercepts shown above do NOT include any corrections or adjustments.

Streams may be combined, in which case capacity will be adjusted.

Values are shown for the first time segment only; they may differ for subsequent time segments.

Traffic Demand

Demand Set Details

ID	Scenario name	Time Period name	Description	Traffic profile type	Start time (HH:mm)	Finish time (HH:mm)	Time segment length (min)	Run automatically
D1	Base	AM	J14 Otterpool Park AM PEAK	ONE HOUR	07:45	09:15	15	9

Vehicle mix varies over turn	Vehicle mix varies over entry	Vehicle mix source	PCU Factor for a HV (PCU)
9	9	HV Percentages	2.00

Demand overview (Traffic)

Arm	Linked arm	Profile type	Use O-D data	Average Demand (Veh/hr)	Scaling Factor (%)
A		ONE HOUR	9	397	100.000
B		ONE HOUR	9	209	100.000
C		ONE HOUR	9	573	100.000

Origin -Destination Data

Demand (Veh/hr)

		To				
From		\$	%	&		
		\$	0	37	360	
		%	32	0	177	
		&	393	180	0	

Vehicle Mix

Heavy Vehicle Percentages

		To				
From		\$	%	&		
		\$	0	5	6	
		%	0	0	1	
		&	4	1	0	

Results

Results Summary for whole modelled period

Stream	Max RFC	Max delay (s)	Max Queue (Veh)	Max LOS	Average Demand (Veh/hr)	Total Junction Arrivals (Veh)
B-AC	0.43	11.73	0.7	B	192	288
C-AB	0.37	9.45	0.6	A	177	265
C-A					349	524
A-B					34	51
A-C					330	496

Main Results for each time segment

07:45 - 08:00

Stream	Total Demand (Veh/hr)	Junction Arrivals (Veh)	Capacity (Veh/hr)	RFC	Throughput (Veh/hr)	Start queue (Veh)	End queue (Veh)	Delay (s)	LOS
B-AC	157	39	586	0.268	156	0.0	0.4	8.336	A
C-AB	139	35	593	0.235	138	0.0	0.3	7.893	A
C-A	292	73			292				
A-B	28	7			28				
A-C	271	68			271				

08:00 - 08:15

Stream	Total Demand (Veh/hr)	Junction Arrivals (Veh)	Capacity (Veh/hr)	RFC	Throughput (Veh/hr)	Start queue (Veh)	End queue (Veh)	Delay (s)	LOS
B-AC	188	47	566	0.332	187	0.4	0.5	9.492	A
C-AB	170	43	592	0.288	170	0.3	0.4	8.527	A
C-A	345	86			345				
A-B	33	8			33				
A-C	324	81			324				

08:15 - 08:30

Stream	Total Demand (Veh/hr)	Junction Arrivals (Veh)	Capacity (Veh/hr)	RFC	Throughput (Veh/hr)	Start queue (Veh)	End queue (Veh)	Delay (s)	LOS
B-AC	230	58	537	0.429	229	0.5	0.7	11.654	B
C-AB	220	55	601	0.366	219	0.4	0.6	9.412	A
C-A	411	103			411				
A-B	41	10			41				
A-C	396	99			396				

08:30 - 08:45

Stream	Total Demand (Veh/hr)	Junction Arrivals (Veh)	Capacity (Veh/hr)	RFC	Throughput (Veh/hr)	Start queue (Veh)	End queue (Veh)	Delay (s)	LOS
B-AC	230	58	537	0.429	230	0.7	0.7	11.728	B
C-AB	220	55	601	0.366	220	0.6	0.6	9.452	A
C-A	411	103			411				
A-B	41	10			41				
A-C	396	99			396				

08:45 - 09:00

Stream	Total Demand (Veh/hr)	Junction Arrivals (Veh)	Capacity (Veh/hr)	RFC	Throughput (Veh/hr)	Start queue (Veh)	End queue (Veh)	Delay (s)	LOS
B-AC	188	47	566	0.332	189	0.7	0.5	9.570	A
C-AB	170	43	592	0.288	171	0.6	0.4	8.578	A
C-A	345	86			345				
A-B	33	8			33				
A-C	324	81			324				

09:00 - 09:15

Stream	Total Demand (Veh/hr)	Junction Arrivals (Veh)	Capacity (Veh/hr)	RFC	Throughput (Veh/hr)	Start queue (Veh)	End queue (Veh)	Delay (s)	LOS
B-AC	157	39	586	0.268	158	0.5	0.4	8.414	A
C-AB	139	35	593	0.235	140	0.4	0.3	7.952	A
C-A	292	73			292				
A-B	28	7			28				
A-C	271	68			271				

Base, PM

Data Errors and Warnings

No errors or warnings

Junction Network

Junctions

Junction	Name	Junction Type	Major road direction	Junction Delay (s)	Junction LOS
1	untitled	T-Junction	Two-way	2.09	A

Junction Network Options

Driving side	Lighting
Left	Normal/unknown

Traffic Demand

Demand Set Details

ID	Scenario name	Time Period name	Description	Traffic profile type	Start time (HH:mm)	Finish time (HH:mm)	Time segment length (min)	Run automatically
D2	Base	PM	J14 Otterpool Park PM PEAK	ONE HOUR	16:45	18:15	15	9

Vehicle mix varies over turn	Vehicle mix varies over entry	Vehicle mix source	PCU Factor for a HV (PCU)
9	9	HV Percentages	2.00

Demand overview (Traffic)

Arm	Linked arm	Profile type	Use O-D data	Average Demand (Veh/hr)	Scaling Factor (%)
A		ONE HOUR	9	561	100.000
B		ONE HOUR	9	148	100.000
C		ONE HOUR	9	453	100.000

Origin -Destination Data

Demand (Veh/hr)

		To			
		\$	%	&	
From	\$	0	36	525	
	%	15	0	133	
	&	347	106	0	

Vehicle Mix

Heavy Vehicle Percentages

		To			
		\$	%	&	
From	\$	0	0	1	
	%	0	0	1	
	&	3	0	0	

Results

Results Summary for whole modelled period

Stream	Max RFC	Max delay (s)	Max Queue (Veh)	Max LOS	Average Demand (Veh/hr)	Total Junction Arrivals (Veh)
B-AC	0.31	10.06	0.5	B	136	204
C-AB	0.23	8.82	0.3	A	100	149
C-A					316	474
A-B					33	50
A-C					482	723

Main Results for each time segment

16:45 - 17:00

Stream	Total Demand (Veh/hr)	Junction Arrivals (Veh)	Capacity (Veh/hr)	RFC	Throughput (Veh/hr)	Start queue (Veh)	End queue (Veh)	Delay (s)	LOS
B-AC	111	28	576	0.194	110	0.0	0.2	7.725	A
C-AB	81	20	561	0.144	80	0.0	0.2	7.467	A
C-A	260	65			260				
A-B	27	7			27				
A-C	395	99			395				

17:00 - 17:15

Stream	Total Demand (Veh/hr)	Junction Arrivals (Veh)	Capacity (Veh/hr)	RFC	Throughput (Veh/hr)	Start queue (Veh)	End queue (Veh)	Delay (s)	LOS
B-AC	133	33	553	0.241	133	0.2	0.3	8.564	A
C-AB	97	24	546	0.178	97	0.2	0.2	8.005	A
C-A	310	78			310				
A-B	32	8			32				
A-C	472	118			472				

17:15 - 17:30

Stream	Total Demand (Veh/hr)	Junction Arrivals (Veh)	Capacity (Veh/hr)	RFC	Throughput (Veh/hr)	Start queue (Veh)	End queue (Veh)	Delay (s)	LOS
B-AC	163	41	521	0.313	162	0.3	0.4	10.029	B
C-AB	121	30	529	0.229	121	0.2	0.3	8.807	A
C-A	377	94			377				
A-B	40	10			40				
A-C	578	145			578				

17:30 - 17:45

Stream	Total Demand (Veh/hr)	Junction Arrivals (Veh)	Capacity (Veh/hr)	RFC	Throughput (Veh/hr)	Start queue (Veh)	End queue (Veh)	Delay (s)	LOS
B-AC	163	41	521	0.313	163	0.4	0.5	10.059	B
C-AB	121	30	529	0.229	121	0.3	0.3	8.820	A
C-A	377	94			377				
A-B	40	10			40				
A-C	578	145			578				

17:45 - 18:00

Stream	Total Demand (Veh/hr)	Junction Arrivals (Veh)	Capacity (Veh/hr)	RFC	Throughput (Veh/hr)	Start queue (Veh)	End queue (Veh)	Delay (s)	LOS
B-AC	133	33	553	0.241	134	0.5	0.3	8.600	A
C-AB	97	24	547	0.178	97	0.3	0.2	8.026	A
C-A	310	78			310				
A-B	32	8			32				
A-C	472	118			472				

18:00 - 18:15

Stream	Total Demand (Veh/hr)	Junction Arrivals (Veh)	Capacity (Veh/hr)	RFC	Throughput (Veh/hr)	Start queue (Veh)	End queue (Veh)	Delay (s)	LOS
B-AC	111	28	576	0.194	112	0.3	0.2	7.769	A
C-AB	81	20	562	0.143	81	0.2	0.2	7.491	A
C-A	260	65			260				
A-B	27	7			27				
A-C	395	99			395				

F.17 J15_Military Rd Dymchurch Rd

Full Input Data And Results
Full Input Data And Results

User and Project Details

Project:	Otterpool Park
Title:	J15 A259/ Dymchurch Rd/ Military Rd gyratory
Location:	Hythe
Additional detail:	
File name:	J15_Scalons Bridge Rd Military Rd Dymchurch Rd_Base Model.lsg3x
Author:	Diego Moreno-Sosa
Company:	ARCADIS UK
Address:	

Network Layout Diagram

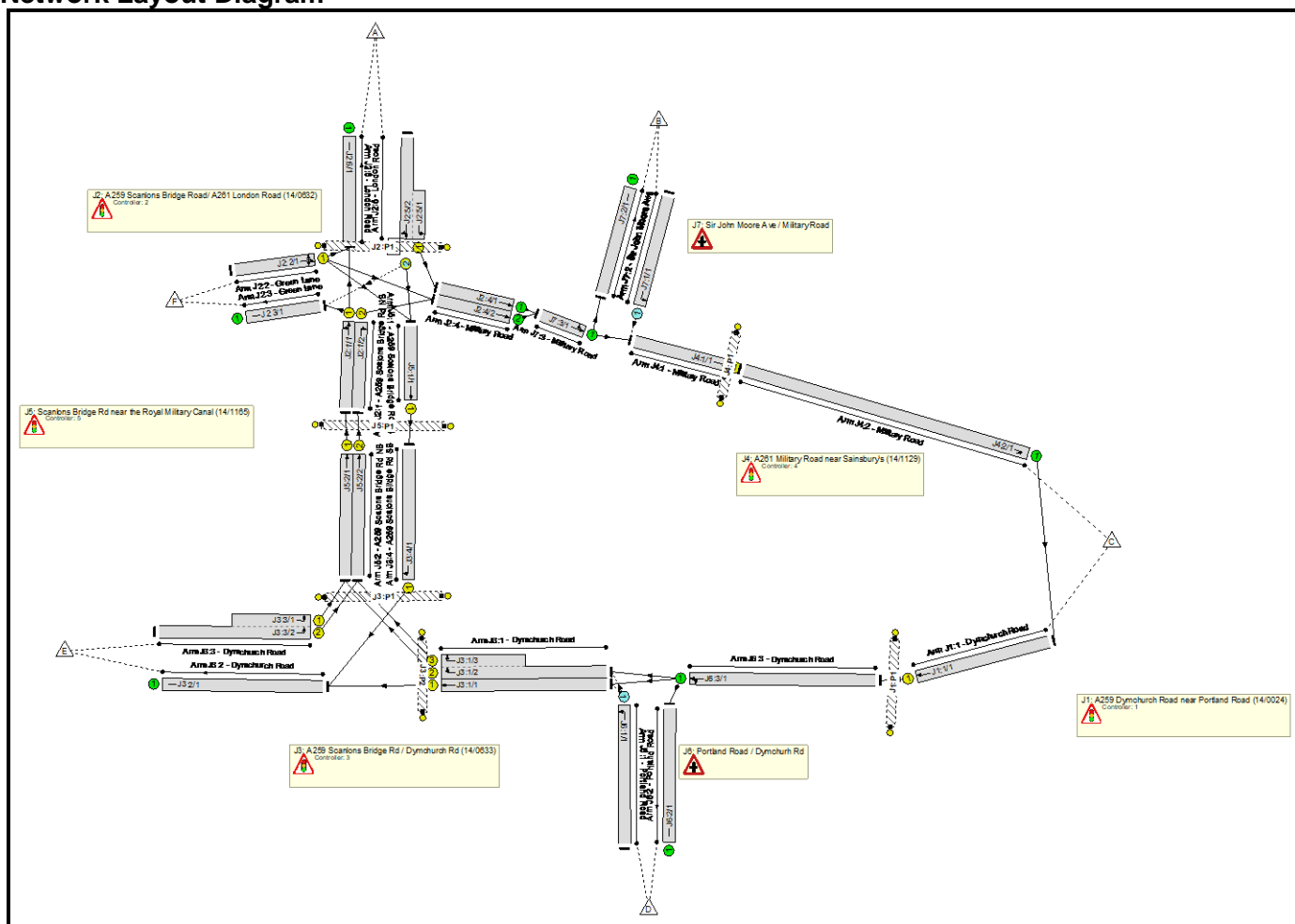

C1 - 14-0024
Phase Input Data

Phase Name	Phase Type	Assoc. Phase	Street Min	Cont Min
A	Traffic		7	7
B	Pedestrian		4	4

Full Input Data And Results

Phase Intergreens Matrix

	Starting Phase		
Terminating Phase		A	B
	A		6
	B	11	

Phases in Stage

Stage No.	Phases in Stage
1	A
2	B

Stage Diagram

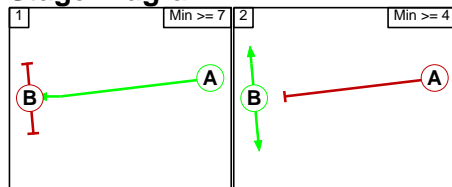

Phase Delays

Term. Stage	Start Stage	Phase	Type	Value	Cont value
There are no Phase Delays defined					

C2 - 14-0632

Phase Input Data

Phase Name	Phase Type	Assoc. Phase	Street Min	Cont Min
A	Traffic		7	7
B	Traffic		7	7
C	Traffic		7	7
D	Traffic		7	7
E	Traffic		7	7
F	Dummy		4	4
G	Dummy		12	12

Full Input Data And Results

Phase Intergreens Matrix

		Starting Phase						
		A	B	C	D	E	F	G
Terminating Phase	A		6	-	5	-	3	-
	B	5		5	5	-	3	-
	C	-	6		-	-	3	-
	D	5	5	-		-	3	-
	E	-	-	-	-		-	-
	F	2	2	2	2	-		-
	G	-	-	-	-	-	-	

Phases in Stage

Stage No.	Phases in Stage
1	A C E
2	C D E G
3	B E
4	E F

Stage Diagram

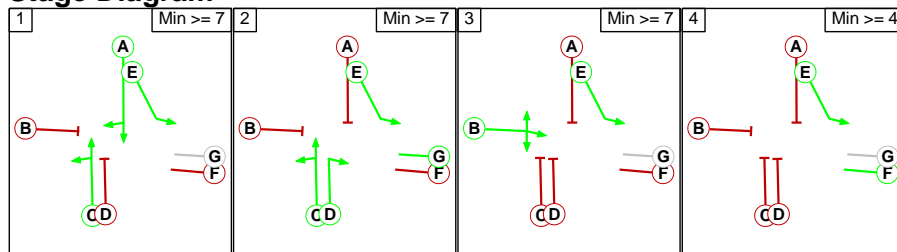

Phase Delays

Term. Stage	Start Stage	Phase	Type	Value	Cont value
There are no Phase Delays defined					

C3 - 14-0633

Phase Input Data

Phase Name	Phase Type	Assoc. Phase	Street Min	Cont Min
A	Traffic		7	7
B	Traffic		7	7
C	Traffic		7	7
D	Traffic		7	7
E	Dummy		7	7
F	Dummy		1	1

Full Input Data And Results

Phase Intergreens Matrix

		Starting Phase					
		A	B	C	D	E	F
Terminating Phase	A	-	-	6	-	-	3
	B	-	-	6	7	-	3
	C	5	5	-	-	5	3
	D	-	5	-	-	-	3
	E	-	-	6	-	-	3
	F	2	2	2	2	2	-

Phases in Stage

Stage No.	Phases in Stage
1	A B E
2	A D E
3	C D

Stage Diagram

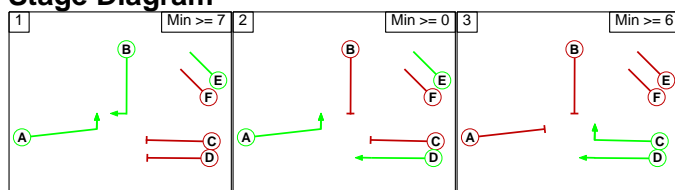

Phase Delays

Term. Stage	Start Stage	Phase	Type	Value	Cont value
There are no Phase Delays defined					

C4 - 14-1129

Phase Input Data

Phase Name	Phase Type	Assoc. Phase	Street Min	Cont Min
A	Traffic		7	7
B	Pedestrian		5	5

Phase Intergreens Matrix

		Starting Phase	
		A	B
Terminating Phase	A	-	6
	B	7	-

Phases in Stage

Stage No.	Phases in Stage
1	A
2	B

Full Input Data And Results

Stage Diagram

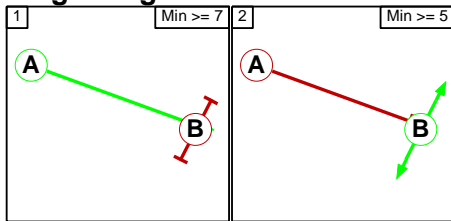

Phase Delays

Term. Stage	Start Stage	Phase	Type	Value	Cont value
There are no Phase Delays defined					

C5 - 14-1165

Phase Input Data

Phase Name	Phase Type	Assoc. Phase	Street Min	Cont Min
A	Traffic		7	7
B	Traffic		7	7
C	Pedestrian		7	7

Phase Intergreens Matrix

		Starting Phase		
		A	B	C
Terminating Phase	A			
	B			
	C	7	7	
		6	6	

Phases in Stage

Stage No.	Phases in Stage
1	A B
2	C

Stage Diagram

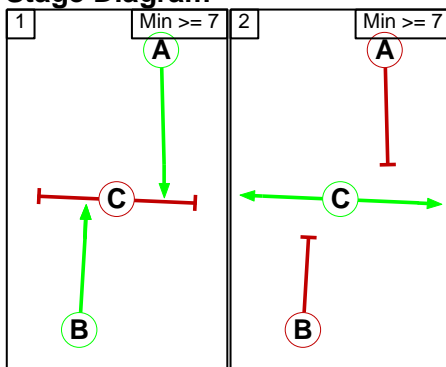

Phase Delays

Term. Stage	Start Stage	Phase	Type	Value	Cont value
There are no Phase Delays defined					

Full Input Data And Results

Traffic Flows, Desired

Scenario 1: 'Base AM' (FG1: 'AM PEAK', Plan 1: 'Network Control Plan 1')

Desired Flow :

		Destination						
		A	B	C	D	E	F	Tot.
Origin	A	1	48	243	56	192	4	544
	B	24	10	74	18	29	3	158
	C	149	20	91	17	249	9	535
	D	143	16	14	7	84	2	266
	E	284	38	526	49	1	1	899
	F	7	1	20	0	4	0	32
	Tot.	608	133	968	147	559	19	2434

Scenario 2: 'Base PM' (FG2: 'PM PEAK', Plan 1: 'Network Control Plan 1')

Desired Flow :

		Destination						
		A	B	C	D	E	F	Tot.
Origin	A	0	87	288	27	225	10	637
	B	40	8	146	22	70	1	287
	C	165	46	89	17	429	3	749
	D	72	27	20	11	110	4	244
	E	179	62	413	13	2	3	672
	F	13	1	18	0	4	0	36
	Tot.	469	231	974	90	840	21	2625

Scenario 1: 'Base AM' (FG1: 'AM PEAK', Plan 1: 'Network Control Plan 1')

C1 - 14-0024

Stage Sequence Diagram

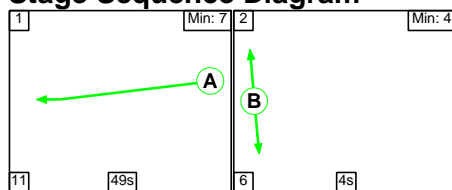

Stage Timings

Stage	1	2
Duration	49	4
Change Point	0	60

Signal Timings Diagram

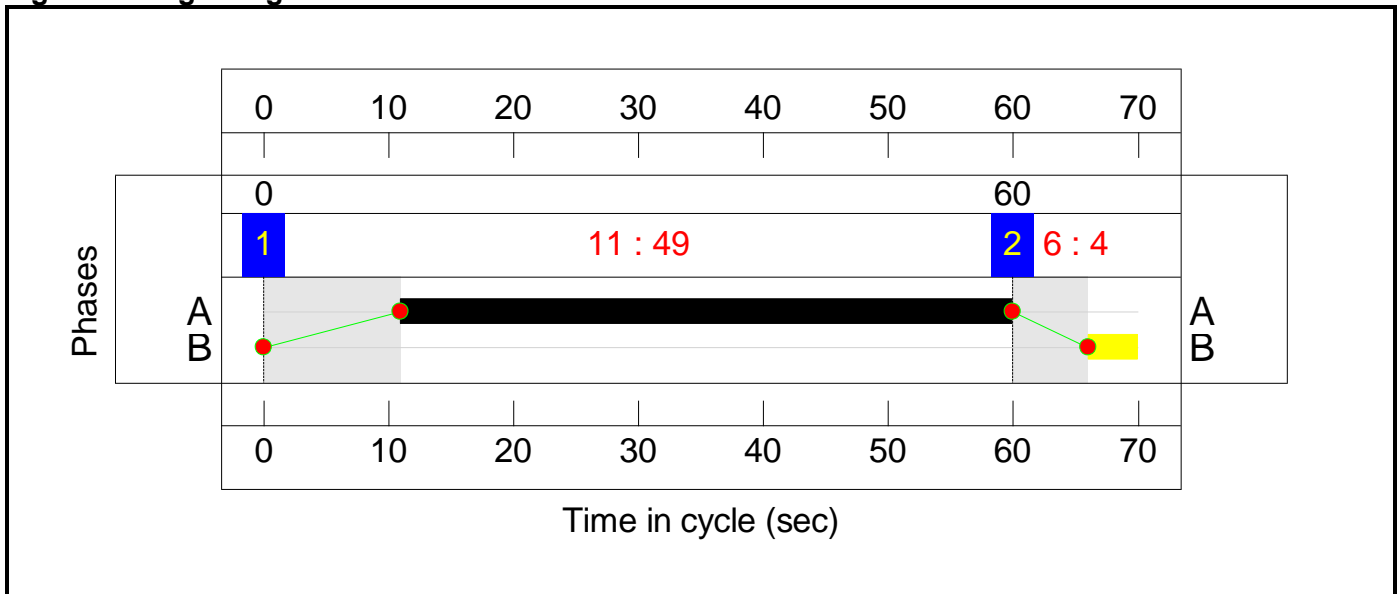

C2 - 14-0632

Stage Sequence Diagram

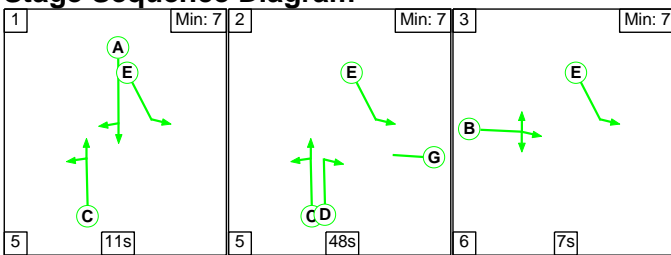

Stage Timings

Stage	1	2	3
Duration	11	48	7
Change Point	0	16	69

Signal Timings Diagram

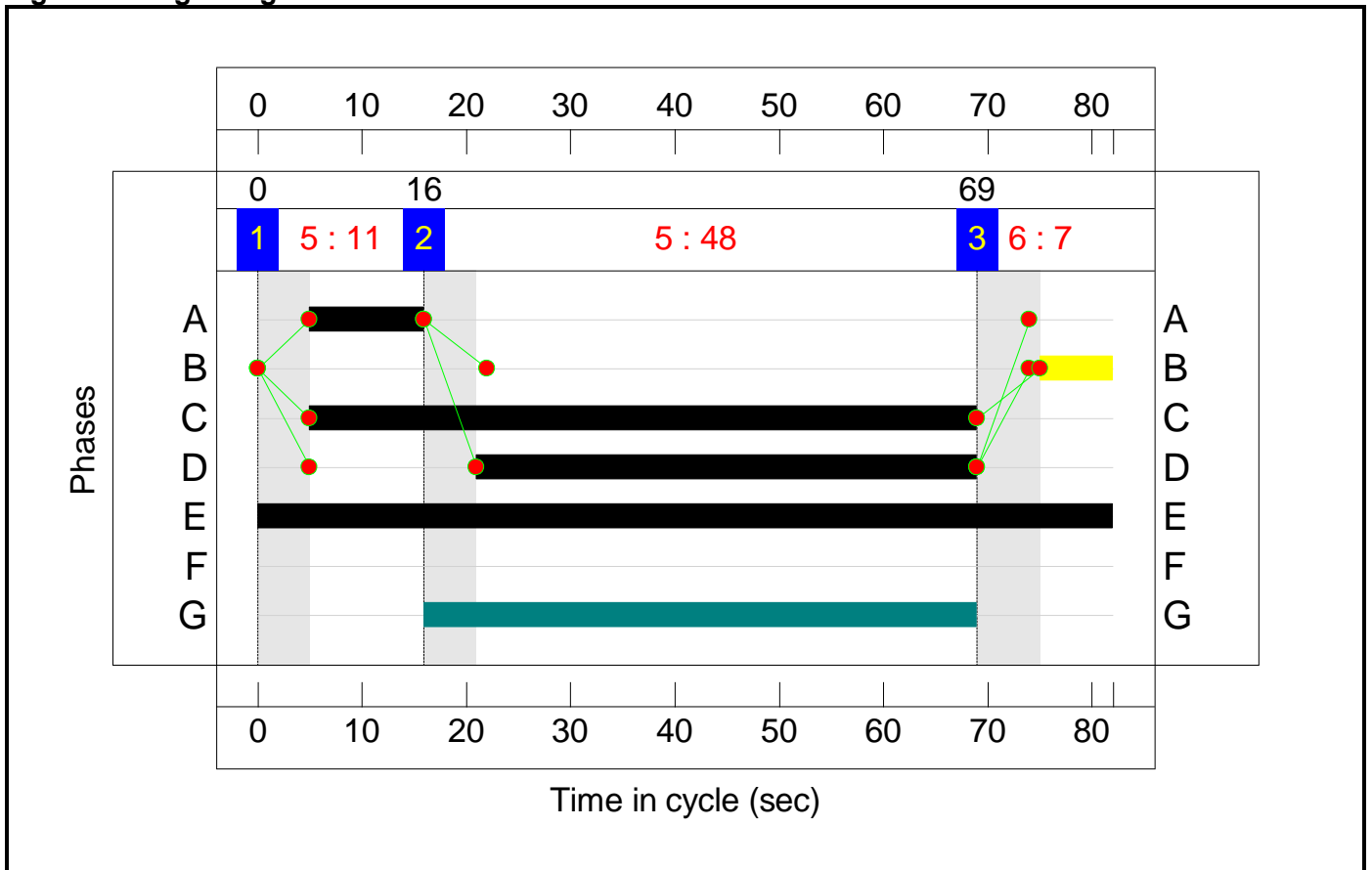

C3 - 14-0633

Stage Sequence Diagram

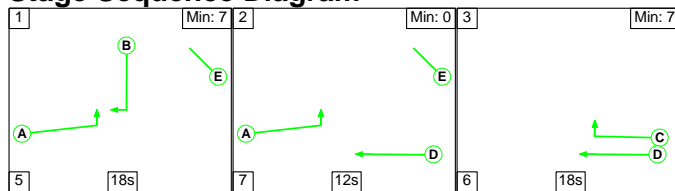

Stage Timings

Stage	1	2	3
Duration	18	12	18
Change Point	0	23	42

Signal Timings Diagram

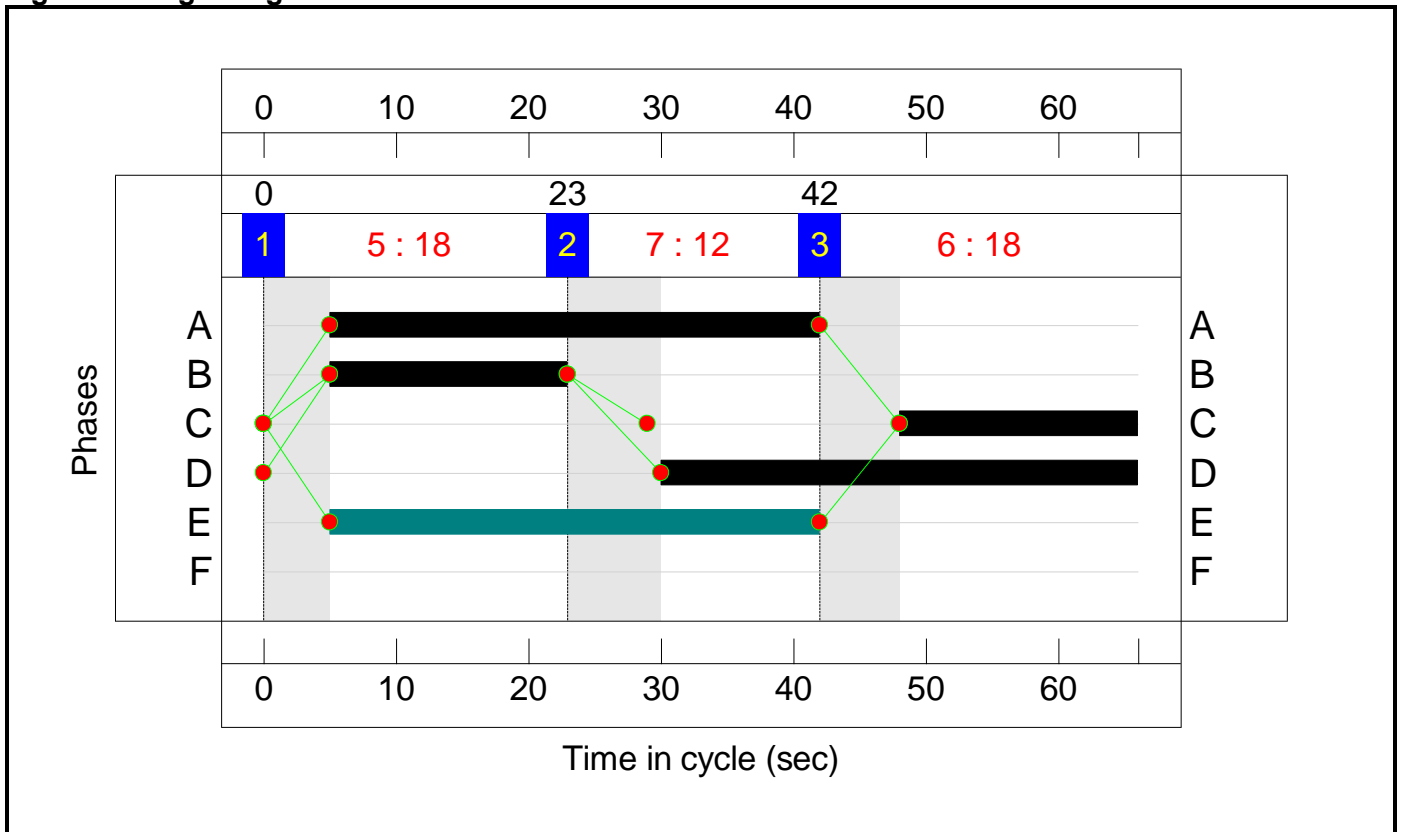

C4 - 14-1129

Stage Sequence Diagram

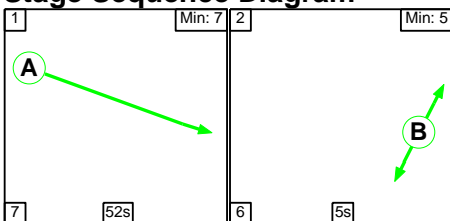

Stage Timings

Stage	1	2
Duration	52	5
Change Point	34	23

Signal Timings Diagram

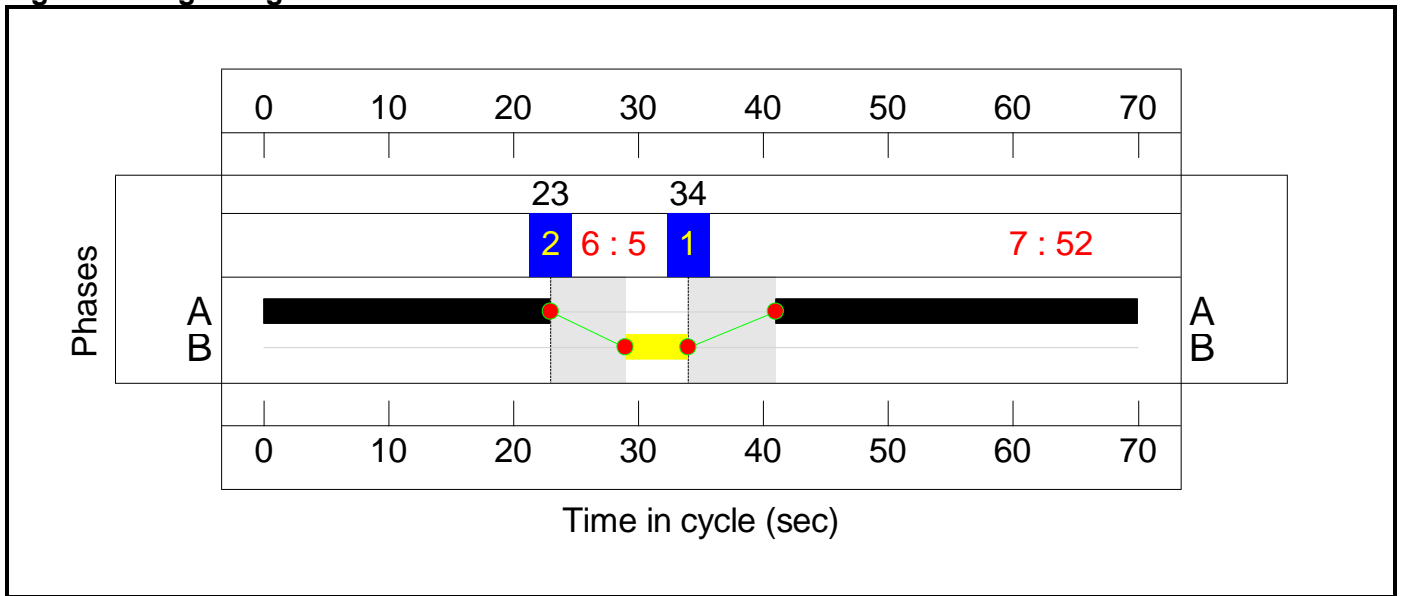

C5 - 14-1165

Stage Sequence Diagram

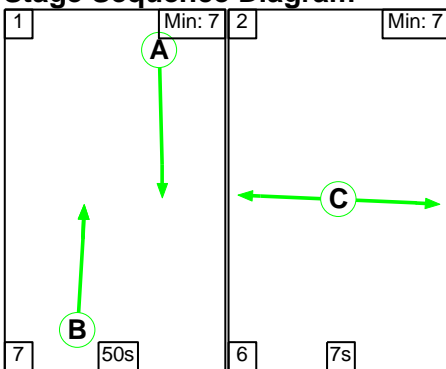

Stage Timings

Stage	1	2
Duration	50	7
Change Point	0	57

Signal Timings Diagram

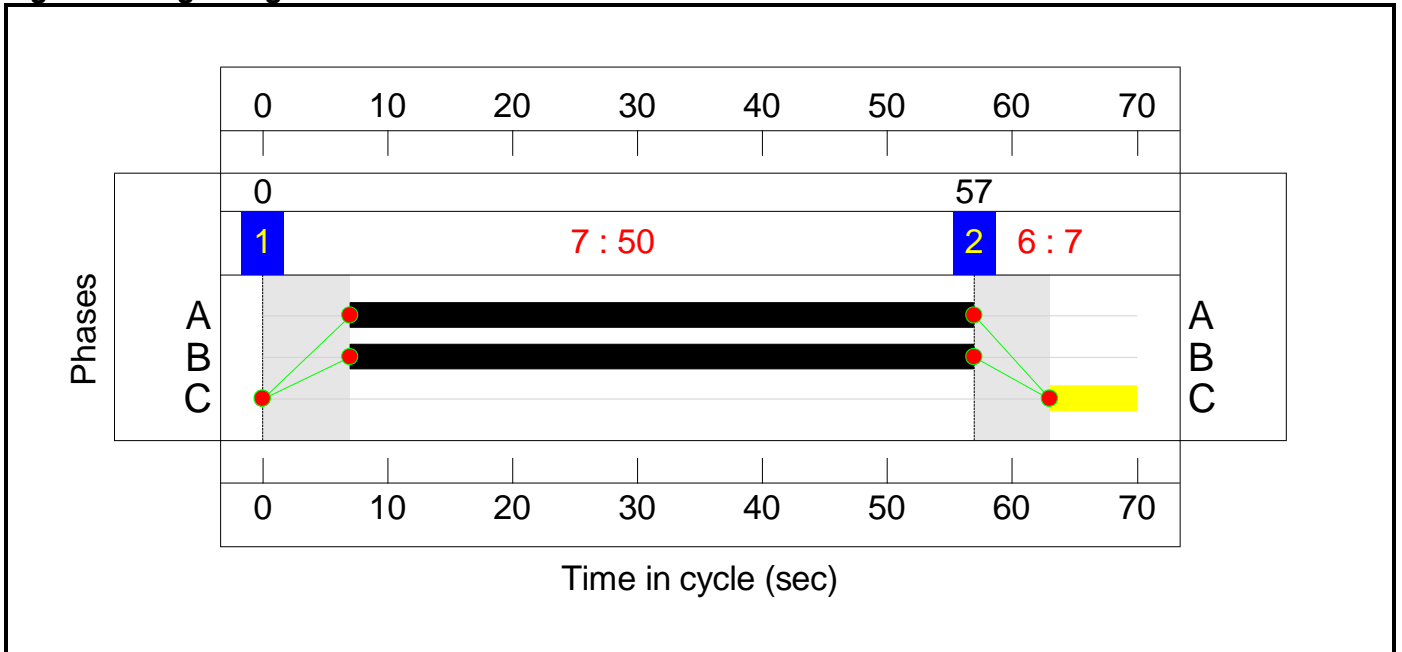

Full Input Data And Results
Network Layout Diagram

Full Input Data And Results

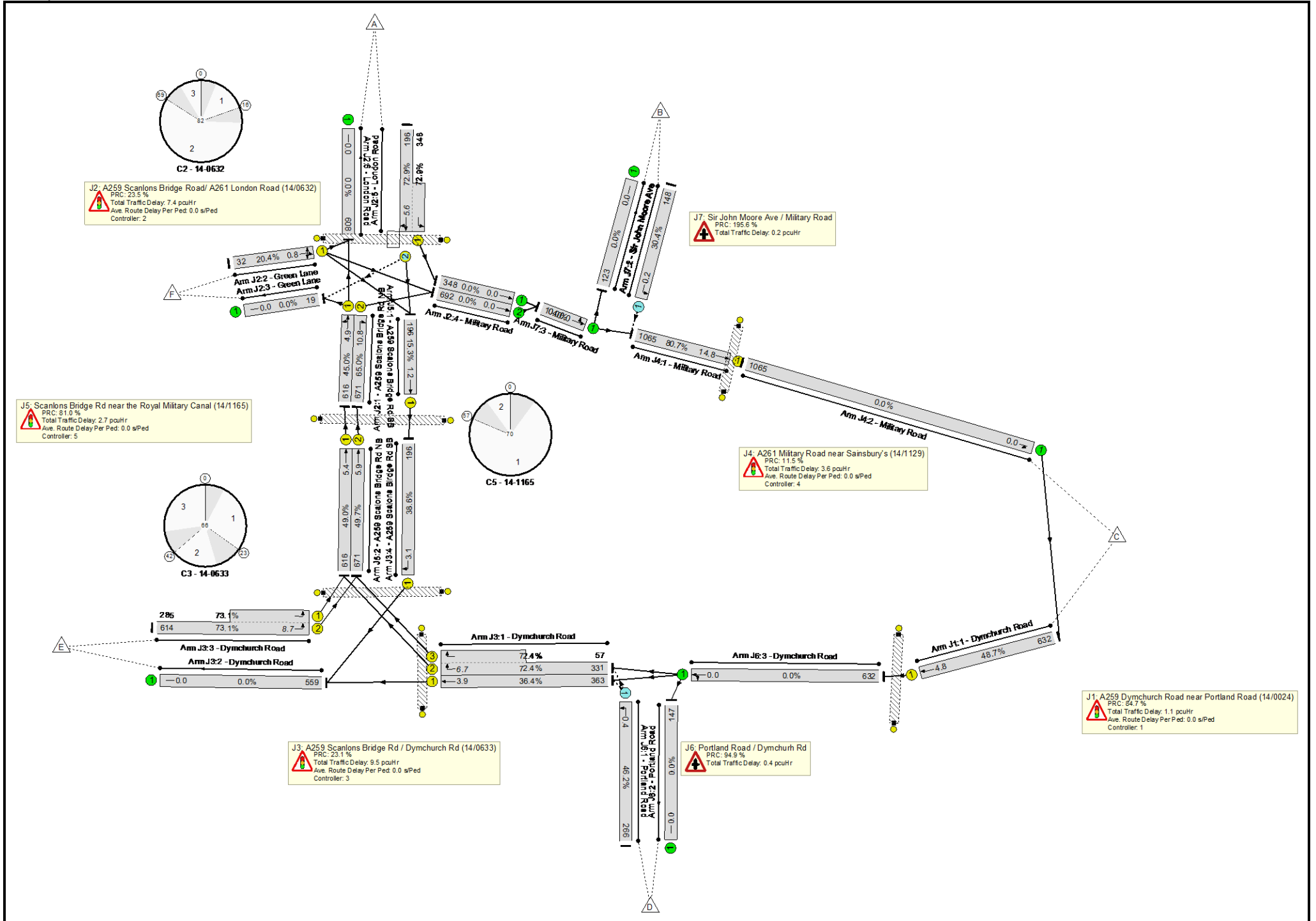

Full Input Data And Results

Full Input Data And Results

Network Results

Scenario 1: 'Base AM' (FG1: 'AM PEAK', Plan 1: 'Network Control Plan 1')

Item	Lane Description	Lane Type	Total Green (s)	Arrow Green (s)	Demand Flow (pcu)	Sat Flow (pcu/Hr)	Capacity (pcu)	Deg Sat (%)	Arriving (pcu)
Network: J15 A259/ Dymchurch Rd/ Military Rd gyratory	-	-	-	-	-	-	-	80.7%	-
J1: A259 Dymchurch Road near Portland Road (14/0024)	-	-	-	-	-	-	-	48.7%	-
1/1	Dymchurch Road Ahead	U	49	-	632	1816	1297	48.7%	632
Ped Link: P1	Unnamed Ped Link	-	0	-	0	-	0	0.0%	0
J2: A259 Scanlons Bridge Road/ A261 London Road (14/0632)	-	-	-	-	-	-	-	72.9%	-
1/1	A259 Scanlons Bridge Rd NB Left Ahead	U	64	-	616	1725	1367	45.0%	616
1/2	A259 Scanlons Bridge Rd NB Right	U	48	-	671	1727	1032	65.0%	671
2/1	Green Lane Right Ahead Left	U	7	-	32	1609	157	20.4%	32
3/1	Green Lane	U	-	-	19	Inf	Inf	0.0%	19
4/1	Military Road Ahead	U	-	-	348	Inf	Inf	0.0%	348
4/2	Military Road Ahead	U	-	-	692	Inf	Inf	0.0%	692
5/2+5/1	London Road Ahead Right Left	O+U	11:82	-	544	1871:1807	269+478	72.9 : 72.9%	544
6/1	London Road	U	-	-	608	Inf	Inf	0.0%	608
Ped Link: P1	Unnamed Ped Link	-	0	-	0	-	0	0.0%	0
J3: A259 Scanlons Bridge Rd / Dymchurch Rd (14/0633)	-	-	-	-	-	-	-	73.1%	-
1/1	Dymchurch Road Ahead	U	36	-	363	1780	998	36.4%	363
1/2+1/3	Dymchurch Road Right	U	18	-	388	1589:1707	457+79	72.4 : 72.4%	388
2/1	Dymchurch Road	U	-	-	559	Inf	Inf	0.0%	559
3/2+3/1	Dymchurch Road Left	U	37	-	899	1690:1573	840+390	73.1 : 73.1%	899
4/1	A259 Scanlons Birdge Rd SB Right	U	18	-	196	1762	507	38.6%	196

Full Input Data And Results

Ped Link: P1	Unnamed Ped Link	-	0	-	0	-	0	0.0%	0
Ped Link: P2	Unnamed Ped Link	-	0	-	0	-	0	0.0%	0
J4: A261 Military Road near Sainsbury's (14/1129)	-	-	-	-	-	-	-	80.7%	-
1/1	Military Road Ahead	U	52	-	1065	1743	1320	80.7%	1065
2/1	Military Road U-Turn	U	-	-	1065	Inf	Inf	0.0%	1065
Ped Link: P1	Unnamed Ped Link	-	0	-	0	-	0	0.0%	0
J5: Scanlons Bridge Rd near the Royal Military Canal (14/1165)	-	-	-	-	-	-	-	49.7%	-
1/1	A259 Scalons Bridge Rd SB Ahead	U	50	-	196	1762	1284	15.3%	196
2/1	A259 Scalons Bridge Rd NB Ahead	U	50	-	616	1725	1257	49.0%	616
2/2	A259 Scalons Bridge Rd NB Ahead	U	50	-	671	1852	1349	49.7%	671
Ped Link: P1	Unnamed Ped Link	-	0	-	0	-	0	0.0%	0
J6: Portland Road / Dymchurch Rd	-	-	-	-	-	-	-	46.2%	-
1/1	Portland Road Left	O	-	-	266	1598	576	46.2%	266
2/1	Portland Road	U	-	-	147	Inf	Inf	0.0%	147
3/1	Dymchurch Road Ahead Left	U	-	-	632	Inf	Inf	0.0%	632
J7: Sir John Moore Ave / Military Road	-	-	-	-	-	-	-	30.4%	-
1/1	Sir John Moore Ave Left	O	-	-	148	1634	486	30.4%	148
2/1	Sir John Moore Ave	U	-	-	123	Inf	Inf	0.0%	123
3/1	Military Road Ahead Left	U	-	-	1040	Inf	Inf	0.0%	1040

Full Input Data And Results

Ped Link: P1	0	-	-	-	Inf	Inf	-	-	Inf
J5: Scanlons Bridge Rd near the Royal Military Canal (14/1165)	-	0	1.6	1.1	2.7	-	-	-	-
1/1	196	-	0.2	0.1	0.2	4.6	1.1	0.1	1.2
2/1	616	-	0.7	0.5	1.2	6.8	5.0	0.5	5.4
2/2	671	-	0.8	0.5	1.2	6.7	5.4	0.5	5.9
Ped Link: P1	0	-	-	-	Inf	Inf	-	-	Inf
J6: Portland Road / Dymchurch Rd	-	0	0.0	0.4	0.4	-	-	-	-
1/1	266	0	0.0	0.4	0.4	5.8	0.0	0.4	0.4
2/1	147	-	0.0	0.0	0.0	0.0	0.0	0.0	0.0
3/1	632	-	0.0	0.0	0.0	0.0	0.0	0.0	0.0
J7: Sir John Moore Ave / Military Road	-	0	0.0	0.2	0.2	-	-	-	-
1/1	148	0	0.0	0.2	0.2	5.3	0.0	0.2	0.2
2/1	123	-	0.0	0.0	0.0	0.0	0.0	0.0	0.0
3/1	1040	-	0.0	0.0	0.0	0.0	0.0	0.0	0.0
C1 - 14-0024	PRC for Signalled Lanes (%)	84.7	Total Delay for Signalled Lanes (pcuHr)	1.10	Cycle Time (s)	70			
C2 - 14-0632	PRC for Signalled Lanes (%)	23.5	Total Delay for Signalled Lanes (pcuHr)	7.41	Cycle Time (s)	82			
C3 - 14-0633	PRC for Signalled Lanes (%)	23.1	Total Delay for Signalled Lanes (pcuHr)	9.45	Cycle Time (s)	66			
C4 - 14-1129	PRC for Signalled Lanes (%)	11.5	Total Delay for Signalled Lanes (pcuHr)	3.63	Cycle Time (s)	70			
C5 - 14-1165	PRC for Signalled Lanes (%)	81.0	Total Delay for Signalled Lanes (pcuHr)	2.66	Cycle Time (s)	70			
	PRC Over All Lanes (%)	11.5	Total Delay Over All Lanes(pcuHr)	24.90					

Full Input Data And Results

Scenario 2: 'Base PM' (FG2: 'PM PEAK ', Plan 1: 'Network Control Plan 1')

Item	Lane Description	Lane Type	Total Green (s)	Arrow Green (s)	Demand Flow (pcu)	Sat Flow (pcu/Hr)	Capacity (pcu)	Deg Sat (%)	Arriving (pcu)
Network: J15 A259/ Dymchurch Rd/ Military Rd gyratory	-	-	-	-	-	-	-	84.7%	-
J1: A259 Dymchurch Road near Portland Road (14/0024)	-	-	-	-	-	-	-	68.8%	-
1/1	Dymchurch Road Ahead	U	41	-	846	1816	1230	68.8%	846
Ped Link: P1	Unnamed Ped Link	-	0	-	0	-	0	0.0%	0
J2: A259 Scamlons Bridge Road/ A261 London Road (14/0632)	-	-	-	-	-	-	-	70.3%	-
1/1	A259 Scamlons Bridge Rd NB Left Ahead	U	48	-	467	1725	1281	36.5%	467
1/2	A259 Scamlons Bridge Rd NB Right	U	32	-	594	1727	863	68.8%	594
2/1	Green Lane Right Ahead Left	U	7	-	36	1609	195	18.5%	36
3/1	Green Lane	U	-	-	21	Inf	Inf	0.0%	21
4/1	Military Road Ahead	U	-	-	402	Inf	Inf	0.0%	402
4/2	Military Road Ahead	U	-	-	613	Inf	Inf	0.0%	613
5/2+5/1	London Road Ahead Right Left	O+U	11:66	-	637	1871:1807	334+572	70.3 : 70.3%	637
6/1	London Road	U	-	-	469	Inf	Inf	0.0%	469
Ped Link: P1	Unnamed Ped Link	-	0	-	0	-	0	0.0%	0
J3: A259 Scamlons Bridge Rd / Dymchurch Rd (14/0633)	-	-	-	-	-	-	-	58.5%	-
1/1	Dymchurch Road Ahead	U	39	-	611	1780	1095	55.8%	611
1/2+1/3	Dymchurch Road Right	U	19	-	389	1589:1707	489+178	58.3 : 58.3%	389
2/1	Dymchurch Road	U	-	-	840	Inf	Inf	0.0%	840
3/2+3/1	Dymchurch Road Left	U	35	-	672	1690:1573	838+311	58.5 : 58.5%	672
4/1	A259 Scamlons Birdge Rd SB Right	U	14	-	229	1762	407	56.3%	229
Ped Link: P1	Unnamed Ped Link	-	0	-	0	-	0	0.0%	0

Full Input Data And Results

Ped Link: P2	Unnamed Ped Link	-	0	-	0	-	0	0.0%	0
J4: A261 Military Road near Sainsbury's (14/1129)	-	-	-	-	-	-	-	84.7%	-
1/1	Military Road Ahead	U	44	-	1071	1743	1265	84.7%	1071
2/1	Military Road U-Turn	U	-	-	1071	Inf	Inf	0.0%	1071
Ped Link: P1	Unnamed Ped Link	-	0	-	0	-	0	0.0%	0
J5: Scanlons Bridge Rd near the Royal Military Canal (14/1165)	-	-	-	-	-	-	-	46.2%	-
1/1	A259 Scalons Bridge Rd SB Ahead	U	42	-	229	1762	1222	18.7%	229
2/1	A259 Scalons Bridge Rd NB Ahead	U	42	-	467	1725	1196	39.0%	467
2/2	A259 Scalons Bridge Rd NB Ahead	U	42	-	594	1852	1284	46.2%	594
Ped Link: P1	Unnamed Ped Link	-	0	-	0	-	0	0.0%	0
J6: Portland Road / Dymchurch Rd	-	-	-	-	-	-	-	46.1%	-
1/1	Portland Road Left	O	-	-	244	1598	529	46.1%	244
2/1	Portland Road	U	-	-	90	Inf	Inf	0.0%	90
3/1	Dymchurch Road Ahead Left	U	-	-	846	Inf	Inf	0.0%	846
J7: Sir John Moore Ave / Military Road	-	-	-	-	-	-	-	56.7%	-
1/1	Sir John Moore Ave Left	O	-	-	279	1634	492	56.7%	279
2/1	Sir John Moore Ave	U	-	-	223	Inf	Inf	0.0%	223
3/1	Military Road Ahead Left	U	-	-	1015	Inf	Inf	0.0%	1015

Full Input Data And Results

Ped Link: P1	0	-	-	-	Inf	Inf	-	-	Inf																																										
J5: Scanlons Bridge Rd near the Royal Military Canal (14/1165)	-	0	1.4	0.9	2.3	-	-	-	-																																										
1/1	229	-	0.2	0.1	0.3	5.2	1.3	0.1	1.5																																										
2/1	467	-	0.5	0.3	0.8	6.5	3.4	0.3	3.7																																										
2/2	594	-	0.7	0.4	1.1	6.9	4.5	0.4	4.9																																										
Ped Link: P1	0	-	-	-	Inf	Inf	-	-	Inf																																										
J6: Portland Road / Dymchurch Rd	-	0	0.0	0.4	0.4	-	-	-	-																																										
1/1	244	0	0.0	0.4	0.4	6.3	0.0	0.4	0.4																																										
2/1	90	-	0.0	0.0	0.0	0.0	0.0	0.0	0.0																																										
3/1	846	-	0.0	0.0	0.0	0.0	0.0	0.0	0.0																																										
J7: Sir John Moore Ave / Military Road	-	0	0.0	0.7	0.7	-	-	-	-																																										
1/1	279	0	0.0	0.7	0.7	8.5	0.9	0.7	1.6																																										
2/1	223	-	0.0	0.0	0.0	0.0	0.0	0.0	0.0																																										
3/1	1015	-	0.0	0.0	0.0	0.0	0.0	0.0	0.0																																										
<table> <tbody> <tr> <td>C1 - 14-0024</td> <td>PRC for Signalled Lanes (%)</td> <td>30.9</td> <td>Total Delay for Signalled Lanes (pcuHr)</td> <td>2.31</td> <td>Cycle Time (s)</td> <td>62</td> </tr> <tr> <td>C2 - 14-0632</td> <td>PRC for Signalled Lanes (%)</td> <td>28.1</td> <td>Total Delay for Signalled Lanes (pcuHr)</td> <td>7.05</td> <td>Cycle Time (s)</td> <td>66</td> </tr> <tr> <td>C3 - 14-0633</td> <td>PRC for Signalled Lanes (%)</td> <td>53.9</td> <td>Total Delay for Signalled Lanes (pcuHr)</td> <td>8.91</td> <td>Cycle Time (s)</td> <td>65</td> </tr> <tr> <td>C4 - 14-1129</td> <td>PRC for Signalled Lanes (%)</td> <td>6.3</td> <td>Total Delay for Signalled Lanes (pcuHr)</td> <td>4.48</td> <td>Cycle Time (s)</td> <td>62</td> </tr> <tr> <td>C5 - 14-1165</td> <td>PRC for Signalled Lanes (%)</td> <td>94.6</td> <td>Total Delay for Signalled Lanes (pcuHr)</td> <td>2.30</td> <td>Cycle Time (s)</td> <td>62</td> </tr> <tr> <td></td> <td>PRC Over All Lanes (%)</td> <td>6.3</td> <td>Total Delay Over All Lanes(pcuHr)</td> <td>26.14</td> <td></td> <td></td> </tr> </tbody> </table>										C1 - 14-0024	PRC for Signalled Lanes (%)	30.9	Total Delay for Signalled Lanes (pcuHr)	2.31	Cycle Time (s)	62	C2 - 14-0632	PRC for Signalled Lanes (%)	28.1	Total Delay for Signalled Lanes (pcuHr)	7.05	Cycle Time (s)	66	C3 - 14-0633	PRC for Signalled Lanes (%)	53.9	Total Delay for Signalled Lanes (pcuHr)	8.91	Cycle Time (s)	65	C4 - 14-1129	PRC for Signalled Lanes (%)	6.3	Total Delay for Signalled Lanes (pcuHr)	4.48	Cycle Time (s)	62	C5 - 14-1165	PRC for Signalled Lanes (%)	94.6	Total Delay for Signalled Lanes (pcuHr)	2.30	Cycle Time (s)	62		PRC Over All Lanes (%)	6.3	Total Delay Over All Lanes(pcuHr)	26.14		
C1 - 14-0024	PRC for Signalled Lanes (%)	30.9	Total Delay for Signalled Lanes (pcuHr)	2.31	Cycle Time (s)	62																																													
C2 - 14-0632	PRC for Signalled Lanes (%)	28.1	Total Delay for Signalled Lanes (pcuHr)	7.05	Cycle Time (s)	66																																													
C3 - 14-0633	PRC for Signalled Lanes (%)	53.9	Total Delay for Signalled Lanes (pcuHr)	8.91	Cycle Time (s)	65																																													
C4 - 14-1129	PRC for Signalled Lanes (%)	6.3	Total Delay for Signalled Lanes (pcuHr)	4.48	Cycle Time (s)	62																																													
C5 - 14-1165	PRC for Signalled Lanes (%)	94.6	Total Delay for Signalled Lanes (pcuHr)	2.30	Cycle Time (s)	62																																													
	PRC Over All Lanes (%)	6.3	Total Delay Over All Lanes(pcuHr)	26.14																																															

F.18 J16_A259 Prospect Rd Station Rd

<h1>Junctions 9</h1>
<h2>ARCADY 9 - Roundabout Module</h2>
Version: 9.0.2.5947 © Copyright TRL Limited, 2017
For sales and distribution information, program advice and maintenance, contact TRL: +44 (0)1344 770558 software@trl.co.uk www.trlsoftware.co.uk
The users of this computer program for the solution of an engineering problem are in no way relieved of their responsibility for the correctness of the solution

Filename: J16_A259 Prospect Rd Station Rd_Base Model.j9
Path: K:\UA008926 Otterpool\D-Calcs\Modelling\DM_it5\Appendix\Appendix Base Models\Arcady\J16 Prospect Rd - Seabrook Rd - Station Rd - High Street
Report generation date: 20/11/2018 15:28:54

- »Base, AM
- »Base, PM

Summary of junction performance

	AM				PM			
	Queue (Veh)	Delay (s)	RFC	LOS	Queue (Veh)	Delay (s)	RFC	LOS
	Base							
Arm A	0.6	5.15	0.36	A	0.6	5.44	0.38	A
Arm B	0.7	4.10	0.40	A	1.0	4.82	0.50	A
Arm C	2.2	8.59	0.69	A	2.5	9.47	0.72	A

Values shown are the highest values encountered over all time segments. Delay is the maximum value of average delay per arriving vehicle.

File summary

File Description

Title	J16 Otterpool Park_Base Model AM PEAK
Location	A259 - High St - Station Rd - Prospect Rd
Site number	
Date	08/08/2017
Version	
Status	Base
Identifier	
Client	
Jobnumber	
Enumerator	dma78191 [C8Z9W0G2]
Description	

Units

Distance units	Speed units	Traffic units input	Traffic units results	Flow units	Average delay units	Total delay units	Rate of delay units
m	kph	Veh	Veh	perHour	s	-Hour	perHour

Analysis Options

Vehicle length (m)	Calculate Queue Percentiles	Calculate detailed queueing delay	Calculate residual capacity	RFC Threshold	Average Delay threshold (s)	Queue threshold (PCU)
5.75				0.85	36.00	20.00

Demand Set Summary

ID	Scenario name	Time Period name	Traffic profile type	Start time (HH:mm)	Finish time (HH:mm)	Time segment length (min)	Run automatically
D1	Base	AM	ONE HOUR	07:45	09:15	15	9
D2	Base	PM	ONE HOUR	16:30	18:00	15	9

Analysis Set Details

ID	Include in report	Network flow scaling factor (%)	Network capacity scaling factor (%)
A1	9	100.000	100.000

Base, AM

Data Errors and Warnings

No errors or warnings

Junction Network

Junctions

Junction	Name	Junction Type	Arm order	Junction Delay (s)	Junction LOS
1	untitled	Standard Roundabout	A, B, C, D	6.48	A

Junction Network Options

Driving side	Lighting
Left	Normal/unknown

Arms

Arms

Arm	Name	Description
A	Station Road	
B	A259 Seabrook Rd	
C	Prospect Road	
D	High Street	

Roundabout Geometry

Arm	V - Approach road half - width (m)	E - Entry width (m)	I' - Effective flare length (m)	R - Entry radius (m)	D - Inscribed circle diameter (m)	PHI - Conflict (entry) angle (deg)	Exit only
A	3.02	5.90	18.6	23.0	29.1	34.0	
B	2.85	6.90	26.2	49.2	29.1	31.0	
C	2.91	5.20	26.4	46.0	29.1	20.0	
D							9

Slope / Intercept / Capacity

Roundabout Slope and Intercept used in model

Arm	Final slope	Final intercept (PCU/hr)
A	0.613	1487
B	0.672	1728
C	0.640	1514
D		

The slope and intercept shown above include any corrections and adjustments.

Traffic Demand

Demand Set Details

ID	Scenario name	Time Period name	Traffic profile type	Start time (HH:mm)	Finish time (HH:mm)	Time segment length (min)	Run automatically
D1	Base	AM	ONE HOUR	07:45	09:15	15	9

Vehicle mix varies over turn	Vehicle mix varies over entry	Vehicle mix source	PCU Factor for a HV (PCU)
9	9	HV Percentages	2.00

Demand overview (Traffic)

Arm	Linked arm	Profile type	Use O-D data	Average Demand (Veh/hr)	Scaling Factor (%)
A		ONE HOUR	9	361	100.000
B		ONE HOUR	9	539	100.000
C		ONE HOUR	9	841	100.000
D					

Origin -Destination Data

Demand (Veh/hr)

From	To			
	\$	%	&	'
\$	2	117	215	27
%	145	14	350	30
&	244	493	56	48
'	Exit-only	Exit-only	Exit-only	Exit-only

Vehicle Mix

Heavy Vehicle Percentages

From	To			
	\$	%	&	'
\$	0	0	1	0
%	1	0	3	0
&	0	1	2	6
'	Exit-only	Exit-only	Exit-only	Exit-only

Results

Results Summary for whole modelled period

Arm	Max RFC	Max delay (s)	Max Queue (Veh)	Max LOS	Average Demand (Veh/hr)	Total Junction Arrivals (Veh)
A	0.36	5.15	0.6	A	331	497
B	0.40	4.10	0.7	A	495	742
C	0.69	8.59	2.2	A	772	1158
D						

Main Results for each time segment

07:45 - 08:00

Arm	Total Demand (Veh/hr)	Junction Arrivals (Veh)	Circulating flow (Veh/hr)	Capacity (Veh/hr)	RFC	Throughput (Veh/hr)	Throughput (exit side) (Veh/hr)	Start queue (Veh)	End queue (Veh)	Delay (s)	LOS
A	272	68	422	1219	0.223	271	293	0.0	0.3	3.791	A
B	406	101	225	1541	0.263	404	467	0.0	0.4	3.164	A
C	633	158	164	1394	0.454	630	466	0.0	0.8	4.695	A
D			715				79				

08:00 - 08:15

Arm	Total Demand (Veh/hr)	Junction Arrivals (Veh)	Circulating flow (Veh/hr)	Capacity (Veh/hr)	RFC	Throughput (Veh/hr)	Throughput (exit side) (Veh/hr)	Start queue (Veh)	End queue (Veh)	Delay (s)	LOS
A	325	81	505	1167	0.278	324	351	0.3	0.4	4.266	A
B	485	121	269	1511	0.321	484	560	0.4	0.5	3.503	A
C	756	189	196	1373	0.551	755	558	0.8	1.2	5.807	A
D			856				94				

08:15 - 08:30

Arm	Total Demand (Veh/hr)	Junction Arrivals (Veh)	Circulating flow (Veh/hr)	Capacity (Veh/hr)	RFC	Throughput (Veh/hr)	Throughput (exit side) (Veh/hr)	Start queue (Veh)	End queue (Veh)	Delay (s)	LOS
A	397	99	617	1098	0.362	397	429	0.4	0.6	5.125	A
B	593	148	330	1471	0.403	593	685	0.5	0.7	4.095	A
C	926	231	240	1345	0.688	922	683	1.2	2.1	8.439	A
D			1047				115				

08:30 - 08:45

Arm	Total Demand (Veh/hr)	Junction Arrivals (Veh)	Circulating flow (Veh/hr)	Capacity (Veh/hr)	RFC	Throughput (Veh/hr)	Throughput (exit side) (Veh/hr)	Start queue (Veh)	End queue (Veh)	Delay (s)	LOS
A	397	99	620	1097	0.362	397	430	0.6	0.6	5.146	A
B	593	148	330	1471	0.404	593	687	0.7	0.7	4.104	A
C	926	231	240	1345	0.689	926	684	2.1	2.2	8.587	A
D			1050				116				

08:45 - 09:00

Arm	Total Demand (Veh/hr)	Junction Arrivals (Veh)	Circulating flow (Veh/hr)	Capacity (Veh/hr)	RFC	Throughput (Veh/hr)	Throughput (exit side) (Veh/hr)	Start queue (Veh)	End queue (Veh)	Delay (s)	LOS
A	325	81	509	1165	0.278	325	353	0.6	0.4	4.288	A
B	485	121	270	1510	0.321	485	563	0.7	0.5	3.514	A
C	756	189	196	1373	0.551	760	559	2.2	1.2	5.911	A
D			861				95				

09:00 - 09:15

Arm	Total Demand (Veh/hr)	Junction Arrivals (Veh)	Circulating flow (Veh/hr)	Capacity (Veh/hr)	RFC	Throughput (Veh/hr)	Throughput (exit side) (Veh/hr)	Start queue (Veh)	End queue (Veh)	Delay (s)	LOS
A	272	68	425	1217	0.223	272	295	0.4	0.3	3.811	A
B	406	101	226	1540	0.264	406	471	0.5	0.4	3.179	A
C	633	158	164	1393	0.455	635	468	1.2	0.8	4.757	A
D			720				79				

Base, PM

Data Errors and Warnings

No errors or warnings

Junction Network

Junctions

Junction	Name	Junction Type	Arm order	Junction Delay (s)	Junction LOS
1	untitled	Standard Roundabout	A, B, C, D	7.05	A

Junction Network Options

Driving side	Lighting
Left	Normal/unknown

Traffic Demand

Demand Set Details

ID	Scenario name	Time Period name	Traffic profile type	Start time (HH:mm)	Finish time (HH:mm)	Time segment length (min)	Run automatically
D2	Base	PM	ONE HOUR	16:30	18:00	15	9

Vehicle mix varies over turn	Vehicle mix varies over entry	Vehicle mix source	PCU Factor for a HV (PCU)
9	9	HV Percentages	2.00

Demand overview (Traffic)

Arm	Linked arm	Profile type	Use O-D data	Average Demand (Veh/hr)	Scaling Factor (%)
A		ONE HOUR	9	369	100.000
B		ONE HOUR	9	683	100.000
C		ONE HOUR	9	876	100.000
D					

Origin -Destination Data

Demand (Veh/hr)

		To			
		\$	%	&	'
From	\$	4	126	224	15
	%	134	26	476	48
	&	229	539	50	58
	'	Exit-only	Exit-only	Exit-only	Exit-only

Vehicle Mix

Heavy Vehicle Percentages

		To			
		\$	%	&	'
From	\$	0	0	0	0
	%	0	0	1	0
	&	0	1	2	0
	'	Exit-only	Exit-only	Exit-only	Exit-only

Results

Results Summary for whole modelled period

Arm	Max RFC	Max delay (s)	Max Queue (Veh)	Max LOS	Average Demand (Veh/hr)	Total Junction Arrivals (Veh)
A	0.38	5.44	0.6	A	339	508
B	0.50	4.82	1.0	A	627	941
C	0.72	9.47	2.5	A	804	1206
D						

Main Results for each time segment

16:30 - 16:45

Arm	Total Demand (Veh/hr)	Junction Arrivals (Veh)	Circulating flow (Veh/hr)	Capacity (Veh/hr)	RFC	Throughput (Veh/hr)	Throughput (exit side) (Veh/hr)	Start queue (Veh)	End queue (Veh)	Delay (s)	LOS
A	278	69	460	1202	0.231	277	275	0.0	0.3	3.884	A
B	515	129	219	1569	0.328	513	517	0.0	0.5	3.403	A
C	659	165	170	1395	0.473	656	562	0.0	0.9	4.850	A
D			735				91				

16:45 - 17:00

Arm	Total Demand (Veh/hr)	Junction Arrivals (Veh)	Circulating flow (Veh/hr)	Capacity (Veh/hr)	RFC	Throughput (Veh/hr)	Throughput (exit side) (Veh/hr)	Start queue (Veh)	End queue (Veh)	Delay (s)	LOS
A	332	83	551	1146	0.289	331	330	0.3	0.4	4.416	A
B	614	154	263	1540	0.399	614	620	0.5	0.7	3.886	A
C	788	197	204	1373	0.573	786	673	0.9	1.3	6.108	A
D			881				109				

17:00 - 17:15

Arm	Total Demand (Veh/hr)	Junction Arrivals (Veh)	Circulating flow (Veh/hr)	Capacity (Veh/hr)	RFC	Throughput (Veh/hr)	Throughput (exit side) (Veh/hr)	Start queue (Veh)	End queue (Veh)	Delay (s)	LOS
A	406	102	673	1070	0.380	405	403	0.4	0.6	5.407	A
B	752	188	322	1500	0.502	751	757	0.7	1.0	4.796	A
C	964	241	249	1344	0.717	960	823	1.3	2.5	9.256	A
D			1076				133				

17:15 - 17:30

Arm	Total Demand (Veh/hr)	Junction Arrivals (Veh)	Circulating flow (Veh/hr)	Capacity (Veh/hr)	RFC	Throughput (Veh/hr)	Throughput (exit side) (Veh/hr)	Start queue (Veh)	End queue (Veh)	Delay (s)	LOS
A	406	102	676	1069	0.380	406	404	0.6	0.6	5.435	A
B	752	188	322	1500	0.502	752	760	1.0	1.0	4.817	A
C	964	241	250	1344	0.718	964	825	2.5	2.5	9.468	A
D			1081				133				

17:30 - 17:45

Arm	Total Demand (Veh/hr)	Junction Arrivals (Veh)	Circulating flow (Veh/hr)	Capacity (Veh/hr)	RFC	Throughput (Veh/hr)	Throughput (exit side) (Veh/hr)	Start queue (Veh)	End queue (Veh)	Delay (s)	LOS
A	332	83	555	1143	0.290	333	332	0.6	0.4	4.445	A
B	614	154	264	1539	0.399	616	624	1.0	0.7	3.906	A
C	788	197	204	1373	0.574	792	675	2.5	1.4	6.246	A
D			887				109				

17:45 - 18:00

Am	Total Demand (Veh/hr)	Junction Arrivals (Veh)	Circulating flow (Veh/hr)	Capacity (Veh/hr)	RFC	Throughput (Veh/hr)	Throughput (exit side) (Veh/hr)	Start queue (Veh)	End queue (Veh)	Delay (s)	LOS
A	278	69	464	1200	0.231	278	277	0.4	0.3	3.908	A
B	515	129	221	1568	0.328	515	521	0.7	0.5	3.421	A
C	659	165	171	1394	0.473	661	565	1.4	0.9	4.926	A
D			741				91				

F.19J17_A20 Ashford Rd

Junctions 9
PICADY 9 - Priority Intersection Module
Version: 9.0.2.5947 © Copyright TRL Limited, 2017
For sales and distribution information, program advice and maintenance, contact TRL: +44 (0)1344 770558 software@trl.co.uk www.trlsoftware.co.uk
The users of this computer program for the solution of an engineering problem are in no way relieved of their responsibility for the correctness of the solution

Filename: J17_A20 Ashford Rd_Base Model.j9
Path: K:\UA008926 Otterpool\D-Calcs\Modelling\DM_it5\Appendix\Appendix Base Models\Picady\J17 A20-Ashford Rd A20 M20-J11
Report generation date: 20/11/2018 15:54:15

- »Base, AM
- »Base, PM

Summary of junction performance

	AM				PM			
	Queue (Veh)	Delay (s)	RFC	LOS	Queue (Veh)	Delay (s)	RFC	LOS
	Base							
Stream B-AC	1.2	13.94	0.56	B	0.5	9.58	0.34	A
Stream C-B	0.0	0.00	0.00	A	0.0	0.00	0.00	A

Values shown are the highest values encountered over all time segments. Delay is the maximum value of average delay per arriving vehicle.

File summary

File Description

Title	J17 Otterpool Park_Base Model
Location	A20 Ashford Road - A20 - M20Junction 11
Site number	
Date	19/06/2017
Version	
Status	Base
Identifier	
Client	
Jobnumber	
Enumerator	dma78191 [C8Z9W0G2]
Description	

Units

Distance units	Speed units	Traffic units input	Traffic units results	Flow units	Average delay units	Total delay units	Rate of delay units
m	kph	Veh	Veh	perHour	s	-Hour	perHour

Analysis Options

Vehicle length (m)	Calculate Queue Percentiles	Calculate detailed queueing delay	Calculate residual capacity	RFC Threshold	Average Delay threshold (s)	Queue threshold (PCU)
5.75				0.85	36.00	20.00

Demand Set Summary

ID	Scenario name	Time Period name	Description	Traffic profile type	Start time (HH:mm)	Finish time (HH:mm)	Time segment length (min)	Run automatically
D1	Base	AM	J17 Otterpool Park AM PEAK	ONE HOUR	07:45	09:15	15	9
D2	Base	PM	J17 Otterpool Park PM PEAK	ONE HOUR	16:45	18:15	15	9

Analysis Set Details

ID	Include in report	Network flow scaling factor (%)	Network capacity scaling factor (%)
A1	9	100.000	100.000

Base, AM

Data Errors and Warnings

No errors or warnings

Junction Network

Junctions

Junction	Name	Junction Type	Major road direction	Junction Delay (s)	Junction LOS
1	untitled	T-Junction	Two-way	1.86	A

Junction Network Options

Driving side	Lighting
Left	Normal/unknown

Arms

Arms

Arm	Name	Description	Arm type
A	A20 Southbound		Major
B	A20 Ashford Road		Minor
C	A20 Northbound		Major

Major Arm Geometry

Arm	Width of carriageway (m)	Has kerbed central reserve	Width of kerbed central reserve (m)	Has right turn bay	Visibility for right turn (m)	Blocks?	Blocking queue (PCU)
C	14.18	9	3.44		180.0		-

Geometries for Arm C are measured opposite Arm B. Geometries for Arm A (if relevant) are measured opposite Arm D.

Minor Arm Geometry

Arm	Minor arm type	Lane width (m)	Visibility to left (m)	Visibility to right (m)
B	One lane	4.00	100	88

Slope / Intercept / Capacity

Priority Intersection Slopes and Intercepts

Junction	Stream	Intercept (Veh/hr)	Slope for A-B	Slope for A-C	Slope for C-A	Slope for C-B
1	B-A	657	0.072	0.181	0.114	0.258
1	B-C	747	0.074	0.187	-	-
1	C-B	678	0.169	0.169	-	-

The slopes and intercepts shown above do NOT include any corrections or adjustments.

Streams may be combined, in which case capacity will be adjusted.

Values are shown for the first time segment only; they may differ for subsequent time segments.

Traffic Demand

Demand Set Details

ID	Scenario name	Time Period name	Description	Traffic profile type	Start time (HH:mm)	Finish time (HH:mm)	Time segment length (min)	Run automatically
D1	Base	AM	J17 Otterpool Park AM PEAK	ONE HOUR	07:45	09:15	15	9

Vehicle mix varies over turn	Vehicle mix varies over entry	Vehicle mix source	PCU Factor for a HV (PCU)
9	9	HV Percentages	2.00

Demand overview (Traffic)

Arm	Linked arm	Profile type	Use O-D data	Average Demand (Veh/hr)	Scaling Factor (%)
A		ONE HOUR	9	869	100.000
B		ONE HOUR	9	295	100.000
C		ONE HOUR	9	975	100.000

Origin -Destination Data

Demand (Veh/hr)

		To				
From		\$	%	&		
		\$	0	244	625	
		%	0	0	295	
		&	975	0	0	

Vehicle Mix

Heavy Vehicle Percentages

		To				
From		\$	%	&		
		\$	0	1	8	
		%	0	0	1	
		&	4	0	0	

Results

Results Summary for whole modelled period

Stream	Max RFC	Max delay (s)	Max Queue (Veh)	Max LOS	Average Demand (Veh/hr)	Total Junction Arrivals (Veh)
B-AC	0.56	13.94	1.2	B	271	406
C-A					895	1342
C-B	0.00	0.00	0.0	A	0	0
A-B					224	336
A-C					574	860

Main Results for each time segment

07:45 - 08:00

Stream	Total Demand (Veh/hr)	Junction Arrivals (Veh)	Capacity (Veh/hr)	RFC	Throughput (Veh/hr)	Start queue (Veh)	End queue (Veh)	Delay (s)	LOS
B-AC	222	56	633	0.351	220	0.0	0.5	8.682	A
C-A	734	184			734				
C-B	0	0	561	0.000	0	0.0	0.0	0.000	A
A-B	184	46			184				
A-C	471	118			471				

08:00 - 08:15

Stream	Total Demand (Veh/hr)	Junction Arrivals (Veh)	Capacity (Veh/hr)	RFC	Throughput (Veh/hr)	Start queue (Veh)	End queue (Veh)	Delay (s)	LOS
B-AC	265	66	612	0.434	264	0.5	0.8	10.336	B
C-A	877	219			877				
C-B	0	0	538	0.000	0	0.0	0.0	0.000	A
A-B	219	55			219				
A-C	562	140			562				

08:15 - 08:30

Stream	Total Demand (Veh/hr)	Junction Arrivals (Veh)	Capacity (Veh/hr)	RFC	Throughput (Veh/hr)	Start queue (Veh)	End queue (Veh)	Delay (s)	LOS
B-AC	325	81	583	0.557	323	0.8	1.2	13.746	B
C-A	1073	268			1073				
C-B	0	0	506	0.000	0	0.0	0.0	0.000	A
A-B	269	67			269				
A-C	688	172			688				

08:30 - 08:45

Stream	Total Demand (Veh/hr)	Junction Arrivals (Veh)	Capacity (Veh/hr)	RFC	Throughput (Veh/hr)	Start queue (Veh)	End queue (Veh)	Delay (s)	LOS
B-AC	325	81	583	0.557	325	1.2	1.2	13.935	B
C-A	1073	268			1073				
C-B	0	0	506	0.000	0	0.0	0.0	0.000	A
A-B	269	67			269				
A-C	688	172			688				

08:45 - 09:00

Stream	Total Demand (Veh/hr)	Junction Arrivals (Veh)	Capacity (Veh/hr)	RFC	Throughput (Veh/hr)	Start queue (Veh)	End queue (Veh)	Delay (s)	LOS
B-AC	265	66	612	0.434	267	1.2	0.8	10.498	B
C-A	877	219			877				
C-B	0	0	538	0.000	0	0.0	0.0	0.000	A
A-B	219	55			219				
A-C	562	140			562				

09:00 - 09:15

Stream	Total Demand (Veh/hr)	Junction Arrivals (Veh)	Capacity (Veh/hr)	RFC	Throughput (Veh/hr)	Start queue (Veh)	End queue (Veh)	Delay (s)	LOS
B-AC	222	56	633	0.351	223	0.8	0.5	8.811	A
C-A	734	184			734				
C-B	0	0	561	0.000	0	0.0	0.0	0.000	A
A-B	184	46			184				
A-C	471	118			471				

Base, PM

Data Errors and Warnings

No errors or warnings

Junction Network

Junctions

Junction	Name	Junction Type	Major road direction	Junction Delay (s)	Junction LOS
1	untitled	T-Junction	Two-way	0.82	A

Junction Network Options

Driving side	Lighting
Left	Normal/unknown

Traffic Demand

Demand Set Details

ID	Scenario name	Time Period name	Description	Traffic profile type	Start time (HH:mm)	Finish time (HH:mm)	Time segment length (min)	Run automatically
D2	Base	PM	J17 Otterpool Park PM PEAK	ONE HOUR	16:45	18:15	15	9

Vehicle mix varies over turn	Vehicle mix varies over entry	Vehicle mix source	PCU Factor for a HV (PCU)
9	9	HV Percentages	2.00

Demand overview (Traffic)

Arm	Linked arm	Profile type	Use O-D data	Average Demand (Veh/hr)	Scaling Factor (%)
A		ONE HOUR	9	1020	100.000
B		ONE HOUR	9	179	100.000
C		ONE HOUR	9	846	100.000

Origin -Destination Data

Demand (Veh/hr)

		To			
		\$	%	&	
From	\$	0	328	692	
	%	0	0	179	
	&	846	0	0	

Vehicle Mix

Heavy Vehicle Percentages

		To			
		\$	%	&	
From	\$	0	0	4	
	%	0	0	0	
	&	2	0	0	

Results

Results Summary for whole modelled period

Stream	Max RFC	Max delay (s)	Max Queue (Veh)	Max LOS	Average Demand (Veh/hr)	Total Junction Arrivals (Veh)
B-AC	0.34	9.58	0.5	A	164	246
C-A					776	1164
C-B	0.00	0.00	0.0	A	0	0
A-B					301	451
A-C					635	952

Main Results for each time segment

16:45 - 17:00

Stream	Total Demand (Veh/hr)	Junction Arrivals (Veh)	Capacity (Veh/hr)	RFC	Throughput (Veh/hr)	Start queue (Veh)	End queue (Veh)	Delay (s)	LOS
B-AC	135	34	628	0.215	134	0.0	0.3	7.265	A
C-A	637	159			637				
C-B	0	0	545	0.000	0	0.0	0.0	0.000	A
A-B	247	62			247				
A-C	521	130			521				

17:00 - 17:15

Stream	Total Demand (Veh/hr)	Junction Arrivals (Veh)	Capacity (Veh/hr)	RFC	Throughput (Veh/hr)	Start queue (Veh)	End queue (Veh)	Delay (s)	LOS
B-AC	161	40	605	0.266	161	0.3	0.4	8.095	A
C-A	761	190			761				
C-B	0	0	519	0.000	0	0.0	0.0	0.000	A
A-B	295	74			295				
A-C	622	156			622				

17:15 - 17:30

Stream	Total Demand (Veh/hr)	Junction Arrivals (Veh)	Capacity (Veh/hr)	RFC	Throughput (Veh/hr)	Start queue (Veh)	End queue (Veh)	Delay (s)	LOS
B-AC	197	49	573	0.344	196	0.4	0.5	9.546	A
C-A	931	233			931				
C-B	0	0	483	0.000	0	0.0	0.0	0.000	A
A-B	361	90			361				
A-C	762	190			762				

17:30 - 17:45

Stream	Total Demand (Veh/hr)	Junction Arrivals (Veh)	Capacity (Veh/hr)	RFC	Throughput (Veh/hr)	Start queue (Veh)	End queue (Veh)	Delay (s)	LOS
B-AC	197	49	573	0.344	197	0.5	0.5	9.578	A
C-A	931	233			931				
C-B	0	0	483	0.000	0	0.0	0.0	0.000	A
A-B	361	90			361				
A-C	762	190			762				

17:45 - 18:00

Stream	Total Demand (Veh/hr)	Junction Arrivals (Veh)	Capacity (Veh/hr)	RFC	Throughput (Veh/hr)	Start queue (Veh)	End queue (Veh)	Delay (s)	LOS
B-AC	161	40	605	0.266	162	0.5	0.4	8.131	A
C-A	761	190			761				
C-B	0	0	519	0.000	0	0.0	0.0	0.000	A
A-B	295	74			295				
A-C	622	156			622				

18:00 - 18:15

Stream	Total Demand (Veh/hr)	Junction Arrivals (Veh)	Capacity (Veh/hr)	RFC	Throughput (Veh/hr)	Start queue (Veh)	End queue (Veh)	Delay (s)	LOS
B-AC	135	34	628	0.215	135	0.4	0.3	7.307	A
C-A	637	159			637				
C-B	0	0	545	0.000	0	0.0	0.0	0.000	A
A-B	247	62			247				
A-C	521	130			521				

F.20 J18_A20 Sandling Rd

Junctions 9
PICADY 9 - Priority Intersection Module
Version: 9.0.2.5947 © Copyright TRL Limited, 2017
For sales and distribution information, program advice and maintenance, contact TRL: +44 (0)1344 770558 software@trl.co.uk www.trlsoftware.co.uk
The users of this computer program for the solution of an engineering problem are in no way relieved of their responsibility for the correctness of the solution

Filename: J18_A20 Sandling Rd_Base Model.j9
Path: K:\UA008926 Otterpool\D-Calcs\Modelling\DM_it5\Appendix\Appendix Base Models\Picady\J18 A20 Ashford Rd - Sandling Rd
Report generation date: 20/11/2018 15:55:00

- »Base, AM
- »Base, PM

Summary of junction performance

	AM				PM			
	Queue (Veh)	Delay (s)	RFC	LOS	Queue (Veh)	Delay (s)	RFC	LOS
Base								
Stream B-AC	0.9	12.90	0.49	B	0.5	8.47	0.32	A
Stream C-AB	0.4	6.77	0.23	A	0.7	7.87	0.36	A

There are warnings associated with one or more model runs - see the 'Data Errors and Warnings' tables for each Analysis or Demand Set.

Values shown are the highest values encountered over all time segments. Delay is the maximum value of average delay per arriving vehicle.

File summary

File Description

Title	J18 Otterpool Park_Base Model
Location	A20 Ashford Road - Sandling Road
Site number	
Date	19/06/2017
Version	
Status	Base
Identifier	
Client	
Jobnumber	
Enumerator	dma78191 [C8Z9W0G2]
Description	

Units

Distance units	Speed units	Traffic units input	Traffic units results	Flow units	Average delay units	Total delay units	Rate of delay units
m	kph	Veh	Veh	perHour	s	-Hour	perHour

Analysis Options

Vehicle length (m)	Calculate Queue Percentiles	Calculate detailed queueing delay	Calculate residual capacity	RFC Threshold	Average Delay threshold (s)	Queue threshold (PCU)
5.75				0.85	36.00	20.00

Demand Set Summary

ID	Scenario name	Time Period name	Description	Traffic profile type	Start time (HH:mm)	Finish time (HH:mm)	Time segment length (min)	Run automatically
D1	Base	AM	J18 Otterpool Park AM PEAK	ONE HOUR	07:45	09:15	15	9
D2	Base	PM	J18 Otterpool Park PM PEAK	ONE HOUR	16:45	18:15	15	9

Analysis Set Details

ID	Include in report	Network flow scaling factor (%)	Network capacity scaling factor (%)
A1	9	100.000	100.000

Base, AM

Data Errors and Warnings

No errors or warnings

Junction Network

Junctions

Junction	Name	Junction Type	Major road direction	Junction Delay (s)	Junction LOS
1	untitled	T-Junction	Two-way	6.21	A

Junction Network Options

Driving side	Lighting
Left	Normal/unknown

Arms

Arms

Arm	Name	Description	Arm type
A	Sandling Road		Major
B	A20 Ashford Rd NB		Minor
C	A20 Ashford Rd SB		Major

Major Arm Geometry

Arm	Width of carriageway (m)	Has kerbed central reserve	Has right turn bay	Visibility for right turn (m)	Blocks?	Blocking queue (PCU)
C	7.20			100.0	9	0.00

Geometries for Arm C are measured opposite Arm B. Geometries for Arm A (if relevant) are measured opposite Arm D.

Minor Arm Geometry

Arm	Minor arm type	Lane width (m)	Visibility to left (m)	Visibility to right (m)
B	One lane	3.12	41	92

Slope / Intercept / Capacity

Priority Intersection Slopes and Intercepts

Junction	Stream	Intercept (Veh/hr)	Slope for A-B	Slope for A-C	Slope for C-A	Slope for C-B
1	B-A	543	0.094	0.237	0.149	0.338
1	B-C	690	0.100	0.253	-	-
1	C-B	632	0.232	0.232	-	-

The slopes and intercepts shown above do NOT include any corrections or adjustments.

Streams may be combined, in which case capacity will be adjusted.

Values are shown for the first time segment only; they may differ for subsequent time segments.

Traffic Demand

Demand Set Details

ID	Scenario name	Time Period name	Description	Traffic profile type	Start time (HH:mm)	Finish time (HH:mm)	Time segment length (min)	Run automatically
D1	Base	AM	J18 Otterpool Park AM PEAK	ONE HOUR	07:45	09:15	15	9

Vehicle mix varies over turn	Vehicle mix varies over entry	Vehicle mix source	PCU Factor for a HV (PCU)
9	9	HV Percentages	2.00

Demand overview (Traffic)

Arm	Linked arm	Profile type	Use O-D data	Average Demand (Veh/hr)	Scaling Factor (%)
A		ONE HOUR	9	174	100.000
B		ONE HOUR	9	242	100.000
C		ONE HOUR	9	244	100.000

Origin -Destination Data

Demand (Veh/hr)

From	To			
	\$	%	&	
\$	0	52	122	
%	69	0	173	
&	134	110	0	

Vehicle Mix

Heavy Vehicle Percentages

From	To			
	\$	%	&	
\$	0	0	1	
%	12	0	1	
&	0	0	0	

Results

Results Summary for whole modelled period

Stream	Max RFC	Max delay (s)	Max Queue (Veh)	Max LOS	Average Demand (Veh/hr)	Total Junction Arrivals (Veh)
B-AC	0.49	12.90	0.9	B	222	333
C-AB	0.23	6.77	0.4	A	124	186
C-A					100	150
A-B					48	72
A-C					112	168

Main Results for each time segment

07:45 - 08:00

Stream	Total Demand (Veh/hr)	Junction Arrivals (Veh)	Capacity (Veh/hr)	RFC	Throughput (Veh/hr)	Start queue (Veh)	End queue (Veh)	Delay (s)	LOS
B-AC	182	46	567	0.321	180	0.0	0.5	9.263	A
C-AB	98	24	668	0.146	97	0.0	0.2	6.288	A
C-A	86	22			86				
A-B	39	10			39				
A-C	92	23			92				

08:00 - 08:15

Stream	Total Demand (Veh/hr)	Junction Arrivals (Veh)	Capacity (Veh/hr)	RFC	Throughput (Veh/hr)	Start queue (Veh)	End queue (Veh)	Delay (s)	LOS
B-AC	218	54	558	0.390	217	0.5	0.6	10.536	B
C-AB	120	30	676	0.178	120	0.2	0.3	6.479	A
C-A	99	25			99				
A-B	47	12			47				
A-C	110	27			110				

08:15 - 08:30

Stream	Total Demand (Veh/hr)	Junction Arrivals (Veh)	Capacity (Veh/hr)	RFC	Throughput (Veh/hr)	Start queue (Veh)	End queue (Veh)	Delay (s)	LOS
B-AC	266	67	545	0.489	265	0.6	0.9	12.789	B
C-AB	154	39	687	0.225	154	0.3	0.4	6.761	A
C-A	114	29			114				
A-B	57	14			57				
A-C	134	34			134				

08:30 - 08:45

Stream	Total Demand (Veh/hr)	Junction Arrivals (Veh)	Capacity (Veh/hr)	RFC	Throughput (Veh/hr)	Start queue (Veh)	End queue (Veh)	Delay (s)	LOS
B-AC	266	67	545	0.489	266	0.9	0.9	12.897	B
C-AB	155	39	687	0.225	155	0.4	0.4	6.772	A
C-A	114	29			114				
A-B	57	14			57				
A-C	134	34			134				

08:45 - 09:00

Stream	Total Demand (Veh/hr)	Junction Arrivals (Veh)	Capacity (Veh/hr)	RFC	Throughput (Veh/hr)	Start queue (Veh)	End queue (Veh)	Delay (s)	LOS
B-AC	218	54	558	0.390	219	0.9	0.7	10.647	B
C-AB	121	30	676	0.178	121	0.4	0.3	6.494	A
C-A	99	25			99				
A-B	47	12			47				
A-C	110	27			110				

09:00 - 09:15

Stream	Total Demand (Veh/hr)	Junction Arrivals (Veh)	Capacity (Veh/hr)	RFC	Throughput (Veh/hr)	Start queue (Veh)	End queue (Veh)	Delay (s)	LOS
B-AC	182	46	567	0.321	183	0.7	0.5	9.390	A
C-AB	98	24	669	0.146	98	0.3	0.2	6.315	A
C-A	86	22			86				
A-B	39	10			39				
A-C	92	23			92				

Base, PM

Data Errors and Warnings

Severity	Area	Item	Description
Warning	Vehicle Mix		HV% is zero for all movements / time segments. Vehicle Mix matrix should be completed whether working in PCUs or Vehs.

Junction Network

Junctions

Junction	Name	Junction Type	Major road direction	Junction Delay (s)	Junction LOS
1	untitled	T-Junction	Two-way	5.44	A

Junction Network Options

Driving side	Lighting
Left	Normal/unknown

Traffic Demand

Demand Set Details

ID	Scenario name	Time Period name	Description	Traffic profile type	Start time (HH:mm)	Finish time (HH:mm)	Time segment length (min)	Run automatically
D2	Base	PM	J18 Otterpool Park PM PEAK	ONE HOUR	16:45	18:15	15	9

Vehicle mix varies over turn	Vehicle mix varies over entry	Vehicle mix source	PCU Factor for a HV (PCU)
9	9	HV Percentages	2.00

Demand overview (Traffic)

Arm	Linked arm	Profile type	Use O-D data	Average Demand (Veh/hr)	Scaling Factor (%)
A		ONE HOUR	9	97	100.000
B		ONE HOUR	9	178	100.000
C		ONE HOUR	9	328	100.000

Origin -Destination Data

Demand (Veh/hr)

		To			
		\$	%	&	
From	\$	0	68	29	
	%	28	0	150	
	&	148	180	0	

Vehicle Mix

Heavy Vehicle Percentages

		To			
		\$	%	&	
From	\$	0	0	0	
	%	0	0	0	
	&	0	0	0	

Results

Results Summary for whole modelled period

Stream	Max RFC	Max delay (s)	Max Queue (Veh)	Max LOS	Average Demand (Veh/hr)	Total Junction Arrivals (Veh)
B-AC	0.32	8.47	0.5	A	163	245
C-AB	0.36	7.87	0.7	A	206	310
C-A					95	142
A-B					62	94
A-C					27	40

Main Results for each time segment

16:45 - 17:00

Stream	Total Demand (Veh/hr)	Junction Arrivals (Veh)	Capacity (Veh/hr)	RFC	Throughput (Veh/hr)	Start queue (Veh)	End queue (Veh)	Delay (s)	LOS
B-AC	134	34	635	0.211	133	0.0	0.3	7.156	A
C-AB	162	40	688	0.235	160	0.0	0.4	6.806	A
C-A	85	21			85				
A-B	51	13			51				
A-C	22	5			22				

17:00 - 17:15

Stream	Total Demand (Veh/hr)	Junction Arrivals (Veh)	Capacity (Veh/hr)	RFC	Throughput (Veh/hr)	Start queue (Veh)	End queue (Veh)	Delay (s)	LOS
B-AC	160	40	629	0.254	160	0.3	0.3	7.662	A
C-AB	200	50	700	0.286	200	0.4	0.5	7.198	A
C-A	95	24			95				
A-B	61	15			61				
A-C	26	7			26				

17:15 - 17:30

Stream	Total Demand (Veh/hr)	Junction Arrivals (Veh)	Capacity (Veh/hr)	RFC	Throughput (Veh/hr)	Start queue (Veh)	End queue (Veh)	Delay (s)	LOS
B-AC	196	49	621	0.316	196	0.3	0.5	8.449	A
C-AB	257	64	715	0.359	256	0.5	0.7	7.844	A
C-A	104	26			104				
A-B	75	19			75				
A-C	32	8			32				

17:30 - 17:45

Stream	Total Demand (Veh/hr)	Junction Arrivals (Veh)	Capacity (Veh/hr)	RFC	Throughput (Veh/hr)	Start queue (Veh)	End queue (Veh)	Delay (s)	LOS
B-AC	196	49	621	0.316	196	0.5	0.5	8.468	A
C-AB	257	64	715	0.360	257	0.7	0.7	7.869	A
C-A	104	26			104				
A-B	75	19			75				
A-C	32	8			32				

17:45 - 18:00

Stream	Total Demand (Veh/hr)	Junction Arrivals (Veh)	Capacity (Veh/hr)	RFC	Throughput (Veh/hr)	Start queue (Veh)	End queue (Veh)	Delay (s)	LOS
B-AC	160	40	629	0.254	160	0.5	0.3	7.688	A
C-AB	200	50	700	0.286	201	0.7	0.5	7.238	A
C-A	95	24			95				
A-B	61	15			61				
A-C	26	7			26				

18:00 - 18:15

Stream	Total Demand (Veh/hr)	Junction Arrivals (Veh)	Capacity (Veh/hr)	RFC	Throughput (Veh/hr)	Start queue (Veh)	End queue (Veh)	Delay (s)	LOS
B-AC	134	34	635	0.211	134	0.3	0.3	7.198	A
C-AB	162	40	689	0.235	162	0.5	0.4	6.856	A
C-A	85	21			85				
A-B	51	13			51				
A-C	22	5			22				

F.21 J19_A20 Ashford Rd Bargrove

Junctions 9
ARCADY 9 - Roundabout Module
Version: 9.0.2.5947 © Copyright TRL Limited, 2017
For sales and distribution information, program advice and maintenance, contact TRL: +44 (0)1344 770558 software@trl.co.uk www.trlsoftware.co.uk
The users of this computer program for the solution of an engineering problem are in no way relieved of their responsibility for the correctness of the solution

Filename: J19_A20 Ashford Rd Bargrove_Base Model.j9
Path: K:\UA008926 Otterpool\D-Calcs\Modelling\DM_it5\Appendix\Appendix Base Models\Arcady\J19 A20 Ashford Rd-Bargrove
Report generation date: 20/11/2018 15:30:17

- »Base, AM
- »Base, PM

Summary of junction performance

	AM				PM			
	Queue (Veh)	Delay (s)	RFC	LOS	Queue (Veh)	Delay (s)	RFC	LOS
	Base							
Arm A	0.2	2.69	0.18	A	0.2	2.47	0.13	A
Arm B	0.4	3.09	0.28	A	0.5	3.26	0.32	A
Arm C	0.3	3.10	0.22	A	0.2	3.03	0.19	A
Arm D	0.1	2.61	0.07	A	0.1	2.54	0.06	A

Values shown are the highest values encountered over all time segments. Delay is the maximum value of average delay per arriving vehicle.

File summary

File Description

Title	J19 Otterpool Park_Base Model AM PEAK
Location	A20 Ashford Road - Bargrove
Site number	
Date	19/06/2017
Version	
Status	Draft 1
Identifier	
Client	
Jobnumber	
Enumerator	dma78191 [C8Z9W0G2]
Description	

Units

Distance units	Speed units	Traffic units input	Traffic units results	Flow units	Average delay units	Total delay units	Rate of delay units
m	kph	Veh	Veh	perHour	s	-Hour	perHour

Analysis Options

Vehicle length (m)	Calculate Queue Percentiles	Calculate detailed queueing delay	Calculate residual capacity	RFC Threshold	Average Delay threshold (s)	Queue threshold (PCU)
5.75				0.85	36.00	20.00

Demand Set Summary

ID	Scenario name	Time Period name	Traffic profile type	Start time (HH:mm)	Finish time (HH:mm)	Time segment length (min)	Run automatically
D1	Base	AM	ONE HOUR	07:45	09:15	15	9
D2	Base	PM	ONE HOUR	16:30	18:00	15	9

Analysis Set Details

ID	Include in report	Network flow scaling factor (%)	Network capacity scaling factor (%)
A1	9	100.000	100.000

Base, AM

Data Errors and Warnings

No errors or warnings

Junction Network

Junctions

Junction	Name	Junction Type	Arm order	Junction Delay (s)	Junction LOS
1	untitled	Standard Roundabout	A, B, C, D	2.95	A

Junction Network Options

Driving side	Lighting
Left	Normal/unknown

Arms

Arms

Arm	Name	Description
A	Beachborough	
B	A20 Ashford Road Westbound	
C	Bargrove	
D	A20 Ashford Road Eastbound	

Roundabout Geometry

Arm	V - Approach road half - width (m)	E - Entry width (m)	I' - Effective flare length (m)	R - Entry radius (m)	D - Inscribed circle diameter (m)	PHI - Conflict (entry) angle (deg)	Exit only
A	3.46	7.03	21.6	31.6	57.0	13.0	
B	3.30	7.13	20.1	28.9	57.0	39.0	
C	3.42	6.24	22.4	30.4	57.0	23.0	
D	3.88	7.28	16.7	38.7	57.0	38.0	

Slope / Intercept / Capacity

Roundabout Slope and Intercept used in model

Arm	Final slope	Final intercept (PCU/hr)
A	0.629	1891
B	0.568	1693
C	0.587	1713
D	0.589	1792

The slope and intercept shown above include any corrections and adjustments.

Traffic Demand

Demand Set Details

ID	Scenario name	Time Period name	Traffic profile type	Start time (HH:mm)	Finish time (HH:mm)	Time segment length (min)	Run automatically
D1	Base	AM	ONE HOUR	07:45	09:15	15	9

Vehicle mix varies over turn	Vehicle mix varies over entry	Vehicle mix source	PCU Factor for a HV (PCU)
9	9	HV Percentages	2.00

Demand overview (Traffic)

Arm	Linked arm	Profile type	Use O-D data	Average Demand (Veh/hr)	Scaling Factor (%)
A		ONE HOUR	9	266	100.000
B		ONE HOUR	9	412	100.000
C		ONE HOUR	9	302	100.000
D		ONE HOUR	9	101	100.000

Origin -Destination Data

Demand (Veh/hr)

		To				
		\$	%	&	'	
From	\$	1	206	50	9	
	%	137	1	169	105	
	&	37	248	0	17	
	'	5	86	9	1	

Vehicle Mix

Heavy Vehicle Percentages

		To				
		\$	%	&	'	
From	\$	0	1	0	1	
	%	0	0	1	6	
	&	0	4	0	1	
	'	6	0	0	100	

Results

Results Summary for whole modelled period

Arm	Max RFC	Max delay (s)	Max Queue (Veh)	Max LOS	Average Demand (Veh/hr)	Total Junction Arrivals (Veh)
A	0.18	2.69	0.2	A	244	366
B	0.28	3.09	0.4	A	378	567
C	0.22	3.10	0.3	A	277	416
D	0.07	2.61	0.1	A	93	139

Main Results for each time segment

07:45 - 08:00

Arm	Total Demand (Veh/hr)	Junction Arrivals (Veh)	Circulating flow (Veh/hr)	Capacity (Veh/hr)	RFC	Throughput (Veh/hr)	Throughput (exit side) (Veh/hr)	Start queue (Veh)	End queue (Veh)	Delay (s)	LOS
A	200	50	259	1709	0.117	200	135	0.0	0.1	2.385	A
B	310	78	53	1631	0.190	309	406	0.0	0.2	2.722	A
C	227	57	191	1546	0.147	227	171	0.0	0.2	2.727	A
D	76	19	318	1580	0.048	76	99	0.0	0.1	2.393	A

08:00 - 08:15

Arm	Total Demand (Veh/hr)	Junction Arrivals (Veh)	Circulating flow (Veh/hr)	Capacity (Veh/hr)	RFC	Throughput (Veh/hr)	Throughput (exit side) (Veh/hr)	Start queue (Veh)	End queue (Veh)	Delay (s)	LOS
A	239	60	310	1676	0.143	239	162	0.1	0.2	2.504	A
B	370	93	63	1625	0.228	370	486	0.2	0.3	2.868	A
C	271	68	228	1524	0.178	271	205	0.2	0.2	2.873	A
D	91	23	381	1543	0.059	91	119	0.1	0.1	2.479	A

08:15 - 08:30

Arm	Total Demand (Veh/hr)	Junction Arrivals (Veh)	Circulating flow (Veh/hr)	Capacity (Veh/hr)	RFC	Throughput (Veh/hr)	Throughput (exit side) (Veh/hr)	Start queue (Veh)	End queue (Veh)	Delay (s)	LOS
A	293	73	380	1632	0.179	293	198	0.2	0.2	2.688	A
B	454	113	77	1617	0.281	453	595	0.3	0.4	3.093	A
C	333	83	279	1494	0.223	332	251	0.2	0.3	3.098	A
D	111	28	466	1492	0.075	111	145	0.1	0.1	2.607	A

08:30 - 08:45

Arm	Total Demand (Veh/hr)	Junction Arrivals (Veh)	Circulating flow (Veh/hr)	Capacity (Veh/hr)	RFC	Throughput (Veh/hr)	Throughput (exit side) (Veh/hr)	Start queue (Veh)	End queue (Veh)	Delay (s)	LOS
A	293	73	380	1632	0.180	293	198	0.2	0.2	2.688	A
B	454	113	77	1617	0.281	454	596	0.4	0.4	3.093	A
C	333	83	280	1494	0.223	333	251	0.3	0.3	3.098	A
D	111	28	467	1491	0.075	111	145	0.1	0.1	2.607	A

08:45 - 09:00

Arm	Total Demand (Veh/hr)	Junction Arrivals (Veh)	Circulating flow (Veh/hr)	Capacity (Veh/hr)	RFC	Throughput (Veh/hr)	Throughput (exit side) (Veh/hr)	Start queue (Veh)	End queue (Veh)	Delay (s)	LOS
A	239	60	310	1676	0.143	239	162	0.2	0.2	2.507	A
B	370	93	63	1625	0.228	371	487	0.4	0.3	2.872	A
C	271	68	229	1524	0.178	272	205	0.3	0.2	2.875	A
D	91	23	382	1542	0.059	91	119	0.1	0.1	2.482	A

09:00 - 09:15

Arm	Total Demand (Veh/hr)	Junction Arrivals (Veh)	Circulating flow (Veh/hr)	Capacity (Veh/hr)	RFC	Throughput (Veh/hr)	Throughput (exit side) (Veh/hr)	Start queue (Veh)	End queue (Veh)	Delay (s)	LOS
A	200	50	260	1709	0.117	200	136	0.2	0.1	2.386	A
B	310	78	53	1631	0.190	310	408	0.3	0.2	2.728	A
C	227	57	191	1546	0.147	228	172	0.2	0.2	2.733	A
D	76	19	319	1579	0.048	76	99	0.1	0.1	2.394	A

Base, PM

Data Errors and Warnings

No errors or warnings

Junction Network

Junctions

Junction	Name	Junction Type	Arm order	Junction Delay (s)	Junction LOS
1	untitled	Standard Roundabout	A, B, C, D	2.99	A

Junction Network Options

Driving side	Lighting
Left	Normal/unknown

Traffic Demand

Demand Set Details

ID	Scenario name	Time Period name	Traffic profile type	Start time (HH:mm)	Finish time (HH:mm)	Time segment length (min)	Run automatically
D2	Base	PM	ONE HOUR	16:30	18:00	15	9

Vehicle mix varies over turn	Vehicle mix varies over entry	Vehicle mix source	PCU Factor for a HV (PCU)
9	9	HV Percentages	2.00

Demand overview (Traffic)

Arm	Linked arm	Profile type	Use O-D data	Average Demand (Veh/hr)	Scaling Factor (%)
A		ONE HOUR	9	205	100.000
B		ONE HOUR	9	471	100.000
C		ONE HOUR	9	259	100.000
D		ONE HOUR	9	75	100.000

Origin -Destination Data

Demand (Veh/hr)

		To				
		\$	%	&	'	
From	\$	1	149	49	6	
	%	190	2	206	73	
	&	46	203	0	10	
	'	7	57	10	1	

Vehicle Mix

Heavy Vehicle Percentages

		To				
		\$	%	&	'	
From	\$	0	1	0	0	
	%	0	0	0	11	
	&	0	5	0	0	
	'	0	0	0	0	

Results

Results Summary for whole modelled period

Arm	Max RFC	Max delay (s)	Max Queue (Veh)	Max LOS	Average Demand (Veh/hr)	Total Junction Arrivals (Veh)
A	0.13	2.47	0.2	A	188	282
B	0.32	3.26	0.5	A	432	648
C	0.19	3.03	0.2	A	238	356
D	0.06	2.54	0.1	A	69	103

Main Results for each time segment

16:30 - 16:45

Arm	Total Demand (Veh/hr)	Junction Arrivals (Veh)	Circulating flow (Veh/hr)	Capacity (Veh/hr)	RFC	Throughput (Veh/hr)	Throughput (exit side) (Veh/hr)	Start queue (Veh)	End queue (Veh)	Delay (s)	LOS
A	154	39	205	1745	0.088	154	183	0.0	0.1	2.263	A
B	355	89	50	1637	0.217	353	309	0.0	0.3	2.803	A
C	195	49	205	1529	0.128	194	199	0.0	0.1	2.695	A
D	56	14	332	1592	0.035	56	68	0.0	0.0	2.343	A

16:45 - 17:00

Arm	Total Demand (Veh/hr)	Junction Arrivals (Veh)	Circulating flow (Veh/hr)	Capacity (Veh/hr)	RFC	Throughput (Veh/hr)	Throughput (exit side) (Veh/hr)	Start queue (Veh)	End queue (Veh)	Delay (s)	LOS
A	184	46	245	1719	0.107	184	219	0.1	0.1	2.345	A
B	423	106	60	1631	0.260	423	369	0.3	0.3	2.980	A
C	233	58	245	1506	0.155	233	238	0.1	0.2	2.827	A
D	67	17	397	1553	0.043	67	81	0.0	0.0	2.423	A

17:00 - 17:15

Arm	Total Demand (Veh/hr)	Junction Arrivals (Veh)	Circulating flow (Veh/hr)	Capacity (Veh/hr)	RFC	Throughput (Veh/hr)	Throughput (exit side) (Veh/hr)	Start queue (Veh)	End queue (Veh)	Delay (s)	LOS
A	226	56	300	1683	0.134	226	268	0.1	0.2	2.469	A
B	519	130	74	1623	0.319	518	452	0.3	0.5	3.255	A
C	285	71	300	1474	0.194	285	292	0.2	0.2	3.028	A
D	83	21	486	1499	0.055	83	99	0.0	0.1	2.540	A

17:15 - 17:30

Arm	Total Demand (Veh/hr)	Junction Arrivals (Veh)	Circulating flow (Veh/hr)	Capacity (Veh/hr)	RFC	Throughput (Veh/hr)	Throughput (exit side) (Veh/hr)	Start queue (Veh)	End queue (Veh)	Delay (s)	LOS
A	226	56	301	1683	0.134	226	269	0.2	0.2	2.470	A
B	519	130	74	1623	0.319	519	453	0.5	0.5	3.257	A
C	285	71	301	1473	0.194	285	292	0.2	0.2	3.028	A
D	83	21	487	1499	0.055	83	99	0.1	0.1	2.541	A

17:30 - 17:45

Arm	Total Demand (Veh/hr)	Junction Arrivals (Veh)	Circulating flow (Veh/hr)	Capacity (Veh/hr)	RFC	Throughput (Veh/hr)	Throughput (exit side) (Veh/hr)	Start queue (Veh)	End queue (Veh)	Delay (s)	LOS
A	184	46	246	1718	0.107	184	220	0.2	0.1	2.346	A
B	423	106	60	1631	0.260	424	370	0.5	0.4	2.982	A
C	233	58	246	1505	0.155	233	238	0.2	0.2	2.831	A
D	67	17	398	1552	0.043	67	81	0.1	0.0	2.425	A

17:45 - 18:00

Arm	Total Demand (Veh/hr)	Junction Arrivals (Veh)	Circulating flow (Veh/hr)	Capacity (Veh/hr)	RFC	Throughput (Veh/hr)	Throughput (exit side) (Veh/hr)	Start queue (Veh)	End queue (Veh)	Delay (s)	LOS
A	154	39	206	1744	0.088	154	184	0.1	0.1	2.265	A
B	355	89	50	1636	0.217	355	310	0.4	0.3	2.809	A
C	195	49	206	1529	0.128	195	200	0.2	0.1	2.701	A
D	56	14	333	1591	0.035	56	68	0.0	0.0	2.345	A

F.22 J20_M20 J12 Cheriton Interchange

Junctions 9
ARCADY 9 - Roundabout Module
Version: 9.0.2.5947 © Copyright TRL Limited, 2017
For sales and distribution information, program advice and maintenance, contact TRL: +44 (0)1344 770558 software@trl.co.uk www.trlsoftware.co.uk
The users of this computer program for the solution of an engineering problem are in no way relieved of their responsibility for the correctness of the solution

Filename: J20_M20 J12 Cheriton Interchange_Base Model.j9

Path: K:\UA008926 Otterpool\D-Calcs\Modelling\DM_it5\Appendix\Appendix Base Models\Arcady\J20 M20 J12 Cheriton interchange

Report generation date: 20/11/2018 15:31:55

»Base, AM

»Base, PM

Summary of junction performance

	AM				PM			
	Queue (Veh)	Delay (s)	RFC	LOS	Queue (Veh)	Delay (s)	RFC	LOS
	Base							
Arm A	0.5	4.68	0.33	A	0.9	5.34	0.47	A
Arm B	0.6	2.05	0.37	A	0.7	2.21	0.42	A
Arm C	1.2	4.57	0.55	A	0.6	3.16	0.37	A
Arm D	0.7	3.93	0.40	A	0.6	3.31	0.36	A

Values shown are the highest values encountered over all time segments. Delay is the maximum value of average delay per arriving vehicle.

File summary

File Description

Title	J20 Otterpool Park Base Model AM PEAK
Location	M20 J12-Cheriton Interchange
Site number	
Date	27/06/2017
Version	
Status	Draft 1
Identifier	
Client	
Jobnumber	
Enumerator	dma78191 [C8Z9W0G2]
Description	

Units

Distance units	Speed units	Traffic units input	Traffic units results	Flow units	Average delay units	Total delay units	Rate of delay units
m	kph	Veh	Veh	perHour	s	-Hour	perHour

Analysis Options

Vehicle length (m)	Calculate Queue Percentiles	Calculate detailed queueing delay	Calculate residual capacity	RFC Threshold	Average Delay threshold (s)	Queue threshold (PCU)
5.75				0.85	36.00	20.00

Demand Set Summary

ID	Scenario name	Time Period name	Traffic profile type	Start time (HH:mm)	Finish time (HH:mm)	Time segment length (min)	Run automatically
D1	Base	AM	ONE HOUR	07:45	09:15	15	9
D2	Base	PM	ONE HOUR	16:30	18:00	15	9

Analysis Set Details

ID	Include in report	Network flow scaling factor (%)	Network capacity scaling factor (%)
A1	9	100.000	100.000

Base, AM

Data Errors and Warnings

No errors or warnings

Junction Network

Junctions

Junction	Name	Junction Type	Arm order	Junction Delay (s)	Junction LOS
1	untitled	Large Roundabout	A, B, C, D	3.58	A

Junction Network Options

Driving side	Lighting
Left	Normal/unknown

Arms

Arms

Arm	Name	Description
A	M20 Westbound	
B	B2064 Cheriton	
C	M20 Eastbound	
D	A20 Ashford Road	

Roundabout Geometry

Arm	V - Approach road half - width (m)	E - Entry width (m)	l' - Effective flare length (m)	R - Entry radius (m)	D - Inscribed circle diameter (m)	PHI - Conflict (entry) angle (deg)	Exit only
A	5.40	6.02	19.8	58.6	179.0	22.0	
B	6.57	8.49	24.9	39.4	167.4	19.0	
C	4.57	6.76	27.6	33.4	179.0	15.0	
D	4.64	6.70	25.1	39.6	179.0	29.0	

Large Roundabout Data

Arm	Circulating flow (PCU/hr)	Entry to -exit separation (m)
A	1140	124.00
B	360	44.00
C	660	105.00
D	1020	28.00

Slope / Intercept / Capacity

Roundabout Slope and Intercept used in model

Arm	Final slope	Final intercept (PCU/hr)
A	0.831	2252
B	1.171	3303
C	0.961	2540
D	0.851	2525

The slope and intercept shown above include any corrections and adjustments.

Traffic Demand

Demand Set Details

ID	Scenario name	Time Period name	Traffic profile type	Start time (HH:mm)	Finish time (HH:mm)	Time segment length (min)	Run automatically
D1	Base	AM	ONE HOUR	07:45	09:15	15	9

Vehicle mix varies over turn	Vehicle mix varies over entry	Vehicle mix source	PCU Factor for a HV (PCU)
9	9	HV Percentages	2.00

Demand overview (Traffic)

Arm	Linked arm	Profile type	Use O-D data	Average Demand (Veh/hr)	Scaling Factor (%)
A		ONE HOUR	9	343	100.000
B		ONE HOUR	9	940	100.000
C		ONE HOUR	9	872	100.000
D		ONE HOUR	9	547	100.000

Origin -Destination Data

Demand (Veh/hr)

		To				
		\$	%	&	'	
From	\$	0	309	0	34	
	%	421	83	249	187	
	&	0	521	4	347	
	'	14	212	321	0	

Vehicle Mix

Heavy Vehicle Percentages

		To				
		\$	%	&	'	
From	\$	0	4	0	3	
	%	1	1	3	0	
	&	0	1	25	1	
	'	7	2	2	0	

Results

Results Summary for whole modelled period

Arm	Max RFC	Max delay (s)	Max Queue (Veh)	Max LOS	Average Demand (Veh/hr)	Total Junction Arrivals (Veh)
A	0.33	4.68	0.5	A	315	472
B	0.37	2.05	0.6	A	863	1294
C	0.55	4.57	1.2	A	800	1200
D	0.40	3.93	0.7	A	502	753

Main Results for each time segment

07:45 - 08:00

Arm	Total Demand (Veh/hr)	Junction Arrivals (Veh)	Circulating flow (Veh/hr)	Capacity (Veh/hr)	RFC	Throughput (Veh/hr)	Throughput (exit side) (Veh/hr)	Start queue (Veh)	End queue (Veh)	Delay (s)	LOS
A	258	65	857	1471	0.176	257	327	0.0	0.2	2.964	A
B	708	177	269	2941	0.241	706	844	0.0	0.3	1.611	A
C	656	164	545	1990	0.330	655	431	0.0	0.5	2.692	A
D	412	103	773	1821	0.226	411	427	0.0	0.3	2.550	A

08:00 - 08:15

Arm	Total Demand (Veh/hr)	Junction Arrivals (Veh)	Circulating flow (Veh/hr)	Capacity (Veh/hr)	RFC	Throughput (Veh/hr)	Throughput (exit side) (Veh/hr)	Start queue (Veh)	End queue (Veh)	Delay (s)	LOS
A	308	77	1025	1335	0.231	308	391	0.2	0.3	3.506	A
B	845	211	322	2878	0.294	845	1010	0.3	0.4	1.769	A
C	784	196	651	1888	0.415	783	516	0.5	0.7	3.253	A
D	492	123	924	1693	0.290	491	510	0.3	0.4	2.995	A

08:15 - 08:30

Arm	Total Demand (Veh/hr)	Junction Arrivals (Veh)	Circulating flow (Veh/hr)	Capacity (Veh/hr)	RFC	Throughput (Veh/hr)	Throughput (exit side) (Veh/hr)	Start queue (Veh)	End queue (Veh)	Delay (s)	LOS
A	378	94	1254	1148	0.329	377	479	0.3	0.5	4.663	A
B	1035	259	395	2793	0.371	1034	1236	0.4	0.6	2.045	A
C	960	240	798	1748	0.549	958	631	0.7	1.2	4.547	A
D	602	151	1131	1519	0.396	601	624	0.4	0.7	3.918	A

08:30 - 08:45

Arm	Total Demand (Veh/hr)	Junction Arrivals (Veh)	Circulating flow (Veh/hr)	Capacity (Veh/hr)	RFC	Throughput (Veh/hr)	Throughput (exit side) (Veh/hr)	Start queue (Veh)	End queue (Veh)	Delay (s)	LOS
A	378	94	1256	1147	0.329	378	479	0.5	0.5	4.681	A
B	1035	259	395	2792	0.371	1035	1239	0.6	0.6	2.048	A
C	960	240	798	1747	0.549	960	632	1.2	1.2	4.572	A
D	602	151	1133	1518	0.397	602	625	0.7	0.7	3.932	A

08:45 - 09:00

Arm	Total Demand (Veh/hr)	Junction Arrivals (Veh)	Circulating flow (Veh/hr)	Capacity (Veh/hr)	RFC	Throughput (Veh/hr)	Throughput (exit side) (Veh/hr)	Start queue (Veh)	End queue (Veh)	Delay (s)	LOS
A	308	77	1028	1332	0.231	309	391	0.5	0.3	3.521	A
B	845	211	323	2877	0.294	846	1014	0.6	0.4	1.774	A
C	784	196	652	1887	0.415	786	517	1.2	0.7	3.274	A
D	492	123	927	1691	0.291	493	512	0.7	0.4	3.004	A

09:00 - 09:15

Arm	Total Demand (Veh/hr)	Junction Arrivals (Veh)	Circulating flow (Veh/hr)	Capacity (Veh/hr)	RFC	Throughput (Veh/hr)	Throughput (exit side) (Veh/hr)	Start queue (Veh)	End queue (Veh)	Delay (s)	LOS
A	258	65	860	1468	0.176	259	328	0.3	0.2	2.975	A
B	708	177	271	2940	0.241	708	848	0.4	0.3	1.612	A
C	656	164	546	1989	0.330	657	433	0.7	0.5	2.706	A
D	412	103	775	1819	0.226	412	428	0.4	0.3	2.561	A

Base, PM

Data Errors and Warnings

No errors or warnings

Junction Network

Junctions

Junction	Name	Junction Type	Arm order	Junction Delay (s)	Junction LOS
1	untitled	Large Roundabout	A, B, C, D	3.24	A

Junction Network Options

Driving side	Lighting
Left	Normal/unknown

Arms

Arms

[same as above]

Roundabout Geometry

[same as above]

Large Roundabout Data

Arm	Circulating flow (PCU/hr)	Entry to -exit separation (m)
A	1140	124.00
B	360	44.00
C	660	105.00
D	1020	28.00

Slope / Intercept / Capacity

[same as above]

Traffic Demand

Demand Set Details

ID	Scenario name	Time Period name	Traffic profile type	Start time (HH:mm)	Finish time (HH:mm)	Time segment length (min)	Run automatically
D2	Base	PM	ONE HOUR	16:30	18:00	15	9

Vehicle mix varies over turn	Vehicle mix varies over entry	Vehicle mix source	PCU Factor for a HV (PCU)
9	9	HV Percentages	2.00

Demand overview (Traffic)

Arm	Linked arm	Profile type	Use O-D data	Average Demand (Veh/hr)	Scaling Factor (%)
A		ONE HOUR	9	535	100.000
B		ONE HOUR	9	1081	100.000
C		ONE HOUR	9	600	100.000
D		ONE HOUR	9	555	100.000

Origin -Destination Data

Demand (Veh/hr)

		To				
		\$	%	&	'	
From	\$	0	511	7	17	
	%	326	164	428	164	
	&	0	354	2	244	
	'	22	200	333	0	

Vehicle Mix

Heavy Vehicle Percentages

		To				
		\$	%	&	'	
From	\$	0	1	14	0	
	%	1	0	0	1	
	&	0	1	0	2	
	'	0	1	2	0	

Results

Results Summary for whole modelled period

Arm	Max RFC	Max delay (s)	Max Queue (Veh)	Max LOS	Average Demand (Veh/hr)	Total Junction Arrivals (Veh)
A	0.47	5.34	0.9	A	491	737
B	0.42	2.21	0.7	A	992	1488
C	0.37	3.16	0.6	A	551	826
D	0.36	3.31	0.6	A	509	764

Main Results for each time segment

16:30 - 16:45

Arm	Total Demand (Veh/hr)	Junction Arrivals (Veh)	Circulating flow (Veh/hr)	Capacity (Veh/hr)	RFC	Throughput (Veh/hr)	Throughput (exit side) (Veh/hr)	Start queue (Veh)	End queue (Veh)	Delay (s)	LOS
A	403	101	790	1569	0.257	402	261	0.0	0.3	3.081	A
B	814	203	269	2968	0.274	812	922	0.0	0.4	1.670	A
C	452	113	504	2024	0.223	451	578	0.0	0.3	2.286	A
D	418	104	635	1949	0.214	417	319	0.0	0.3	2.348	A

16:45 - 17:00

Arm	Total Demand (Veh/hr)	Junction Arrivals (Veh)	Circulating flow (Veh/hr)	Capacity (Veh/hr)	RFC	Throughput (Veh/hr)	Throughput (exit side) (Veh/hr)	Start queue (Veh)	End queue (Veh)	Delay (s)	LOS
A	481	120	945	1440	0.334	481	313	0.3	0.5	3.749	A
B	972	243	322	2905	0.335	971	1104	0.4	0.5	1.861	A
C	539	135	602	1930	0.279	539	692	0.3	0.4	2.587	A
D	499	125	760	1844	0.271	499	382	0.3	0.4	2.675	A

17:00 - 17:15

Am	Total Demand (Veh/hr)	Junction Arrivals (Veh)	Circulating flow (Veh/hr)	Capacity (Veh/hr)	RFC	Throughput (Veh/hr)	Throughput (exit side) (Veh/hr)	Start queue (Veh)	End queue (Veh)	Delay (s)	LOS
A	589	147	1157	1264	0.466	588	383	0.5	0.9	5.311	A
B	1190	298	395	2819	0.422	1190	1351	0.5	0.7	2.209	A
C	661	165	737	1801	0.367	660	847	0.4	0.6	3.153	A
D	611	153	930	1700	0.359	610	467	0.4	0.6	3.301	A

17:15 - 17:30

Am	Total Demand (Veh/hr)	Junction Arrivals (Veh)	Circulating flow (Veh/hr)	Capacity (Veh/hr)	RFC	Throughput (Veh/hr)	Throughput (exit side) (Veh/hr)	Start queue (Veh)	End queue (Veh)	Delay (s)	LOS
A	589	147	1159	1263	0.467	589	383	0.9	0.9	5.343	A
B	1190	298	395	2818	0.422	1190	1353	0.7	0.7	2.211	A
C	661	165	738	1801	0.367	661	848	0.6	0.6	3.157	A
D	611	153	931	1700	0.360	611	468	0.6	0.6	3.306	A

17:30 - 17:45

Am	Total Demand (Veh/hr)	Junction Arrivals (Veh)	Circulating flow (Veh/hr)	Capacity (Veh/hr)	RFC	Throughput (Veh/hr)	Throughput (exit side) (Veh/hr)	Start queue (Veh)	End queue (Veh)	Delay (s)	LOS
A	481	120	947	1439	0.334	483	313	0.9	0.5	3.773	A
B	972	243	323	2904	0.335	973	1107	0.7	0.5	1.864	A
C	539	135	603	1929	0.280	540	693	0.6	0.4	2.592	A
D	499	125	761	1843	0.271	500	382	0.6	0.4	2.682	A

17:45 - 18:00

Am	Total Demand (Veh/hr)	Junction Arrivals (Veh)	Circulating flow (Veh/hr)	Capacity (Veh/hr)	RFC	Throughput (Veh/hr)	Throughput (exit side) (Veh/hr)	Start queue (Veh)	End queue (Veh)	Delay (s)	LOS
A	403	101	793	1567	0.257	404	262	0.5	0.3	3.097	A
B	814	203	270	2966	0.274	814	926	0.5	0.4	1.672	A
C	452	113	505	2023	0.223	452	580	0.4	0.3	2.291	A
D	418	104	637	1948	0.215	418	320	0.4	0.3	2.355	A

F.23 J21A_M20 J13 Castle hill Interchange

Junctions 9
ARCADY 9 - Roundabout Module
Version: 9.0.2.5947 © Copyright TRL Limited, 2017
For sales and distribution information, program advice and maintenance, contact TRL: +44 (0)1344 770558 software@trl.co.uk www.trlsoftware.co.uk
The users of this computer program for the solution of an engineering problem are in no way relieved of their responsibility for the correctness of the solution

Filename: J21A_M20 J13 Castle hill Interchange_Base Model.j9
Path: K:\UA008926 Otterpool\D-Calcs\Modelling\DM_it5\Appendix\Appendix Base Models\Arcady\J21A M20 J13 Castle hill Interchange - Churchill Ave
Report generation date: 20/11/2018 15:33:08

- »Base, AM
- »Base, PM

Summary of junction performance

	AM				PM			
	Queue (Veh)	Delay (s)	RFC	LOS	Queue (Veh)	Delay (s)	RFC	LOS
Base								
Arm A	0.8	4.68	0.46	A	0.4	3.35	0.29	A
Arm B	2.9	8.64	0.75	A	1.7	5.21	0.64	A
Arm C	1.0	4.90	0.51	A	1.2	5.14	0.55	A
Arm E	3.7	11.40	0.79	B	2.5	8.06	0.72	A

There are warnings associated with one or more model runs - see the 'Data Errors and Warnings' tables for each Analysis or Demand Set.

Values shown are the highest values encountered over all time segments. Delay is the maximum value of average delay per arriving vehicle.

File summary

File Description

Title	J21A Otterpool Park_Base Model AM PEAK
Location	J21A M20 J13-Castle hill Interchange
Site number	
Date	27/06/2017
Version	
Status	Draft 1
Identifier	
Client	
Jobnumber	
Enumerator	dma78191 [C8Z9W0G2]
Description	

Units

Distance units	Speed units	Traffic units input	Traffic units results	Flow units	Average delay units	Total delay units	Rate of delay units
m	kph	Veh	Veh	perHour	s	-Hour	perHour

Analysis Options

Vehicle length (m)	Calculate Queue Percentiles	Calculate detailed queueing delay	Calculate residual capacity	RFC Threshold	Average Delay threshold (s)	Queue threshold (PCU)
5.75				0.85	36.00	20.00

Demand Set Summary

ID	Scenario name	Time Period name	Traffic profile type	Start time (HH:mm)	Finish time (HH:mm)	Time segment length (min)	Run automatically
D1	Base	AM	ONE HOUR	07:45	09:15	15	9
D2	Base	PM	ONE HOUR	16:30	18:00	15	9

Analysis Set Details

ID	Include in report	Network flow scaling factor (%)	Network capacity scaling factor (%)
A1	9	100.000	100.000

Base, AM

Data Errors and Warnings

Severity	Area	Item	Description
Warning	Geometry	Arm A - Roundabout Geometry	Effective flare length is over 30m, which is outside the normal range. Treat capacities with increasing caution.
Warning	Geometry	Arm B - Roundabout Geometry	Effective flare length is over 30m, which is outside the normal range. Treat capacities with increasing caution.

Junction Network

Junctions

Junction	Name	Junction Type	Arm order	Junction Delay (s)	Junction LOS
J21A	M20 J13 Castle Hill Interchange	Standard Roundabout	A, B, C, D, E	8.11	A

Junction Network Options

Driving side	Lighting
Left	Normal/unknown

Arms

Arms

Arm	Name	Description
A	M20 Westbound Entry Only	
B	Churchill Avenue	
C	Cherry Garden Avenue	
D	M20 Westbound Exit Only	
E	A20 Castle Hill Bridge	

Roundabout Geometry

Arm	V - Approach road half - width (m)	E - Entry width (m)	I' - Effective flare length (m)	R - Entry radius (m)	D - Inscribed circle diameter (m)	PHI - Conflict (entry) angle (deg)	Exit only
A	5.84	10.80	36.1	15.4	60.0	40.0	
B	3.60	9.60	64.0	24.4	60.0	31.0	
C	3.65	8.18	29.6	18.4	60.0	29.0	
D							9
E	6.40	6.40	0.0	29.6	60.0	48.0	

Slope / Intercept / Capacity

Roundabout Slope and Intercept used in model

Arm	Final slope	Final intercept (PCU/hr)
A	0.713	2675
B	0.698	2503
C	0.613	2026
D		
E	0.571	1849

The slope and intercept shown above include any corrections and adjustments.

Traffic Demand

Demand Set Details

ID	Scenario name	Time Period name	Traffic profile type	Start time (HH:mm)	Finish time (HH:mm)	Time segment length (min)	Run automatically
D1	Base	AM	ONE HOUR	07:45	09:15	15	9

Vehicle mix varies over turn	Vehicle mix varies over entry	Vehicle mix source	PCU Factor for a HV (PCU)
9	9	HV Percentages	2.00

Demand overview (Traffic)

Arm	Linked arm	Profile type	Use O-D data	Average Demand (Veh/hr)	Scaling Factor (%)
A		ONE HOUR	9	592	100.000
B		ONE HOUR	9	1109	100.000
C		ONE HOUR	9	681	100.000
D					
E		ONE HOUR	9	1093	100.000

Origin -Destination Data

Demand (Veh/hr)

		To				
		\$	%	&	'	(
From	\$	0	127	462	2	1
	%	0	0	424	628	57
	&	0	387	40	0	254
	'	Exit-only	Exit-only	Exit-only	Exit-only	Exit-only
	(0	579	513	1	0

Vehicle Mix

Heavy Vehicle Percentages

		To				
		\$	%	&	'	(
From	\$	0	2	1	0	0
	%	0	0	3	4	6
	&	0	3	3	3	5
	'	Exit-only	Exit-only	Exit-only	Exit-only	Exit-only
	(0	4	4	0	0

Results

Results Summary for whole modelled period

Arm	Max RFC	Max delay (s)	Max Queue (Veh)	Max LOS	Average Demand (Veh/hr)	Total Junction Arrivals (Veh)
A	0.46	4.68	0.8	A	543	815
B	0.75	8.64	2.9	A	1018	1526
C	0.51	4.90	1.0	A	625	937
D						
E	0.79	11.40	3.7	B	1003	1504

Main Results for each time segment

07:45 - 08:00

Arm	Total Demand (Veh/hr)	Junction Arrivals (Veh)	Circulating flow (Veh/hr)	Capacity (Veh/hr)	RFC	Throughput (Veh/hr)	Throughput (exit side) (Veh/hr)	Start queue (Veh)	End queue (Veh)	Delay (s)	LOS
A	446	111	1139	1810	0.246	444	0	0.0	0.3	2.634	A
B	835	209	764	1883	0.443	832	819	0.0	0.8	3.416	A
C	513	128	517	1633	0.314	511	1079	0.0	0.5	3.201	A
D			554				473				
E	823	206	320	1603	0.513	819	234	0.0	1.0	4.570	A

08:00 - 08:15

Arm	Total Demand (Veh/hr)	Junction Arrivals (Veh)	Circulating flow (Veh/hr)	Capacity (Veh/hr)	RFC	Throughput (Veh/hr)	Throughput (exit side) (Veh/hr)	Start queue (Veh)	End queue (Veh)	Delay (s)	LOS
A	532	133	1364	1647	0.323	532	0	0.3	0.5	3.227	A
B	997	249	914	1779	0.560	995	981	0.8	1.3	4.580	A
C	612	153	618	1571	0.390	611	1291	0.5	0.6	3.752	A
D			664				566				
E	983	246	383	1567	0.627	980	280	1.0	1.7	6.111	A

08:15 - 08:30

Arm	Total Demand (Veh/hr)	Junction Arrivals (Veh)	Circulating flow (Veh/hr)	Capacity (Veh/hr)	RFC	Throughput (Veh/hr)	Throughput (exit side) (Veh/hr)	Start queue (Veh)	End queue (Veh)	Delay (s)	LOS
A	652	163	1665	1428	0.457	650	0	0.5	0.8	4.624	A
B	1221	305	1117	1640	0.745	1215	1198	1.3	2.8	8.351	A
C	750	187	755	1486	0.504	748	1577	0.6	1.0	4.867	A
D			812				691				
E	1203	301	469	1518	0.793	1196	343	1.7	3.6	10.900	B

08:30 - 08:45

Arm	Total Demand (Veh/hr)	Junction Arrivals (Veh)	Circulating flow (Veh/hr)	Capacity (Veh/hr)	RFC	Throughput (Veh/hr)	Throughput (exit side) (Veh/hr)	Start queue (Veh)	End queue (Veh)	Delay (s)	LOS
A	652	163	1673	1421	0.459	652	0	0.8	0.8	4.677	A
B	1221	305	1122	1637	0.746	1221	1203	2.8	2.9	8.645	A
C	750	187	758	1484	0.505	750	1584	1.0	1.0	4.901	A
D			814				695				
E	1203	301	470	1518	0.793	1203	343	3.6	3.7	11.401	B

08:45 - 09:00

Arm	Total Demand (Veh/hr)	Junction Arrivals (Veh)	Circulating flow (Veh/hr)	Capacity (Veh/hr)	RFC	Throughput (Veh/hr)	Throughput (exit side) (Veh/hr)	Start queue (Veh)	End queue (Veh)	Delay (s)	LOS
A	532	133	1375	1638	0.325	534	0	0.8	0.5	3.265	A
B	997	249	921	1775	0.562	1003	988	2.9	1.3	4.706	A
C	612	153	623	1567	0.391	614	1301	1.0	0.6	3.782	A
D			666				571				
E	983	246	385	1566	0.627	991	281	3.7	1.7	6.342	A

09:00 - 09:15

Arm	Total Demand (Veh/hr)	Junction Arrivals (Veh)	Circulating flow (Veh/hr)	Capacity (Veh/hr)	RFC	Throughput (Veh/hr)	Throughput (exit side) (Veh/hr)	Start queue (Veh)	End queue (Veh)	Delay (s)	LOS
A	446	111	1147	1804	0.247	446	0	0.5	0.3	2.652	A
B	835	209	769	1879	0.444	837	825	1.3	0.8	3.461	A
C	513	128	520	1631	0.314	513	1086	0.6	0.5	3.221	A
D			557				476				
E	823	206	322	1602	0.514	825	235	1.7	1.1	4.653	A

Base, PM

Data Errors and Warnings

Severity	Area	Item	Description
Warning	Geometry	Arm A - Roundabout Geometry	Effective flare length is over 30m, which is outside the normal range. Treat capacities with increasing caution.
Warning	Geometry	Arm B - Roundabout Geometry	Effective flare length is over 30m, which is outside the normal range. Treat capacities with increasing caution.

Junction Network

Junctions

Junction	Name	Junction Type	Arm order	Junction Delay (s)	Junction LOS
J21A	M20 J13 Castle Hill Interchange	Standard Roundabout	A, B, C, D, E	5.85	A

Junction Network Options

Driving side	Lighting
Left	Normal/unknown

Traffic Demand

Demand Set Details

ID	Scenario name	Time Period name	Traffic profile type	Start time (HH:mm)	Finish time (HH:mm)	Time segment length (min)	Run automatically
D2	Base	PM	ONE HOUR	16:30	18:00	15	9

Vehicle mix varies over turn	Vehicle mix varies over entry	Vehicle mix source	PCU Factor for a HV (PCU)
9	9	HV Percentages	2.00

Demand overview (Traffic)

Arm	Linked arm	Profile type	Use O-D data	Average Demand (Veh/hr)	Scaling Factor (%)
A		ONE HOUR	9	399	100.000
B		ONE HOUR	9	1103	100.000
C		ONE HOUR	9	778	100.000
D					
E		ONE HOUR	9	1019	100.000

Origin -Destination Data

Demand (Veh/hr)

From	To					
	\$	%	&	'	(
\$	0	65	331	2	1	
%	0	0	443	549	111	
&	0	393	34	0	351	
'	Exit-only	Exit-only	Exit-only	Exit-only	Exit-only	
(0	639	378	2	0	

Vehicle Mix

Heavy Vehicle Percentages

From	To				
	\$	%	&	'	(
	0	2	1	0	0
	0	0	1	1	2
	0	1	0	0	1
	Exit-only	Exit-only	Exit-only	Exit-only	Exit-only
	0	1	0	0	0

Results

Results Summary for whole modelled period

Arm	Max RFC	Max delay (s)	Max Queue (Veh)	Max LOS	Average Demand (Veh/hr)	Total Junction Arrivals (Veh)
A	0.29	3.35	0.4	A	366	549
B	0.64	5.21	1.7	A	1012	1518
C	0.55	5.14	1.2	A	714	1071
D						
E	0.72	8.06	2.5	A	935	1403

Main Results for each time segment

16:30 - 16:45

Arm	Total Demand (Veh/hr)	Junction Arrivals (Veh)	Circulating flow (Veh/hr)	Capacity (Veh/hr)	RFC	Throughput (Veh/hr)	Throughput (exit side) (Veh/hr)	Start queue (Veh)	End queue (Veh)	Delay (s)	LOS
A	300	75	1084	1875	0.160	300	0	0.0	0.2	2.284	A
B	830	208	561	2086	0.398	828	823	0.0	0.7	2.854	A
C	586	146	499	1700	0.345	584	890	0.0	0.5	3.220	A
D			668				415				
E	767	192	320	1654	0.464	764	347	0.0	0.9	4.028	A

16:45 - 17:00

Arm	Total Demand (Veh/hr)	Junction Arrivals (Veh)	Circulating flow (Veh/hr)	Capacity (Veh/hr)	RFC	Throughput (Veh/hr)	Throughput (exit side) (Veh/hr)	Start queue (Veh)	End queue (Veh)	Delay (s)	LOS
A	359	90	1298	1723	0.208	358	0	0.2	0.3	2.638	A
B	992	248	672	2010	0.493	990	985	0.7	1.0	3.525	A
C	699	175	597	1640	0.427	699	1065	0.5	0.7	3.821	A
D			799				497				
E	916	229	383	1618	0.566	914	416	0.9	1.3	5.104	A

17:00 - 17:15

Arm	Total Demand (Veh/hr)	Junction Arrivals (Veh)	Circulating flow (Veh/hr)	Capacity (Veh/hr)	RFC	Throughput (Veh/hr)	Throughput (exit side) (Veh/hr)	Start queue (Veh)	End queue (Veh)	Delay (s)	LOS
A	439	110	1586	1518	0.289	439	0	0.3	0.4	3.334	A
B	1214	304	821	1906	0.637	1211	1204	1.0	1.7	5.158	A
C	857	214	730	1558	0.550	855	1302	0.7	1.2	5.107	A
D			978				607				
E	1122	280	469	1569	0.715	1117	509	1.3	2.4	7.892	A

17:15 - 17:30

Arm	Total Demand (Veh/hr)	Junction Arrivals (Veh)	Circulating flow (Veh/hr)	Capacity (Veh/hr)	RFC	Throughput (Veh/hr)	Throughput (exit side) (Veh/hr)	Start queue (Veh)	End queue (Veh)	Delay (s)	LOS
A	439	110	1592	1514	0.290	439	0	0.4	0.4	3.348	A
B	1214	304	823	1905	0.638	1214	1208	1.7	1.7	5.215	A
C	857	214	732	1557	0.550	857	1306	1.2	1.2	5.142	A
D			980				609				
E	1122	280	470	1568	0.715	1122	510	2.4	2.5	8.055	A

17:30 - 17:45

Arm	Total Demand (Veh/hr)	Junction Arrivals (Veh)	Circulating flow (Veh/hr)	Capacity (Veh/hr)	RFC	Throughput (Veh/hr)	Throughput (exit side) (Veh/hr)	Start queue (Veh)	End queue (Veh)	Delay (s)	LOS
A	359	90	1306	1717	0.209	359	0	0.4	0.3	2.651	A
B	992	248	675	2008	0.494	995	990	1.7	1.0	3.565	A
C	699	175	600	1638	0.427	701	1070	1.2	0.8	3.850	A
D			802				499				
E	916	229	385	1617	0.567	921	417	2.5	1.3	5.204	A

17:45 - 18:00

Arm	Total Demand (Veh/hr)	Junction Arrivals (Veh)	Circulating flow (Veh/hr)	Capacity (Veh/hr)	RFC	Throughput (Veh/hr)	Throughput (exit side) (Veh/hr)	Start queue (Veh)	End queue (Veh)	Delay (s)	LOS
A	300	75	1091	1870	0.161	301	0	0.3	0.2	2.296	A
B	830	208	564	2084	0.398	832	828	1.0	0.7	2.875	A
C	586	146	501	1698	0.345	587	894	0.8	0.5	3.242	A
D			671				417				
E	767	192	322	1653	0.464	769	349	1.3	0.9	4.081	A

F.24 J21B_M20 J13 Castle hill Interchange

Junctions 9
ARCADY 9 - Roundabout Module
Version: 9.0.2.5947 © Copyright TRL Limited, 2017
For sales and distribution information, program advice and maintenance, contact TRL: +44 (0)1344 770558 software@trl.co.uk www.trlsoftware.co.uk
The users of this computer program for the solution of an engineering problem are in no way relieved of their responsibility for the correctness of the solution

Filename: J21B_M20 J13 Castle hill Interchange_Base Model.j9
Path: K:\UA008926 Otterpool\D-Calcs\Modelling\DM_it5\Appendix\Appendix Base Models\Arcady\J21B M20 J13 Castle hill Interchange
Report generation date: 20/11/2018 15:34:11

- »Base, AM
- »Base, PM

Summary of junction performance

	AM				PM			
	Queue (Veh)	Delay (s)	RFC	LOS	Queue (Veh)	Delay (s)	RFC	LOS
Base								
Arm A	0.0	0.00	0.00	A	0.0	0.00	0.00	A
Arm B	0.3	3.47	0.23	A	0.6	3.95	0.36	A
Arm C	0.9	3.00	0.48	A	1.0	3.33	0.51	A
Arm D	0.0	5.20	0.01	A	0.0	5.23	0.02	A

There are warnings associated with one or more model runs - see the 'Data Errors and Warnings' tables for each Analysis or Demand Set.

Values shown are the highest values encountered over all time segments. Delay is the maximum value of average delay per arriving vehicle.

File summary

File Description

Title	J21B Otterpool Park_Base Model AM PEAK
Location	M20 J13-Castle hill Interchange
Site number	
Date	27/06/2017
Version	
Status	Draft 1
Identifier	
Client	
Jobnumber	
Enumerator	dma78191 [C8Z9W0G2]
Description	

Units

Distance units	Speed units	Traffic units input	Traffic units results	Flow units	Average delay units	Total delay units	Rate of delay units
m	kph	Veh	Veh	perHour	s	-Hour	perHour

Analysis Options

Vehicle length (m)	Calculate Queue Percentiles	Calculate detailed queueing delay	Calculate residual capacity	RFC Threshold	Average Delay threshold (s)	Queue threshold (PCU)
5.75				0.85	36.00	20.00

Demand Set Summary

ID	Scenario name	Time Period name	Traffic profile type	Start time (HH:mm)	Finish time (HH:mm)	Time segment length (min)	Run automatically
D1	Base	AM	ONE HOUR	07:45	09:15	15	9
D2	Base	PM	ONE HOUR	16:30	18:00	15	9

Analysis Set Details

ID	Include in report	Network flow scaling factor (%)	Network capacity scaling factor (%)
A1	9	100.000	100.000

Base, AM

Data Errors and Warnings

Severity	Area	Item	Description
Warning	Geometry	Arm C - Roundabout Geometry	Effective flare length is over 30m, which is outside the normal range. Treat capacities with increasing caution.

Junction Network

Junctions

Junction	Name	Junction Type	Arm order	Junction Delay (s)	Junction LOS
1	untitled	Standard Roundabout	A, B, C, D	3.12	A

Junction Network Options

Driving side	Lighting
Left	Normal/unknown

Arms

Arms

Arm	Name	Description
A	M20 Eastbound Exit Only	
B	Castle Hill Bridge	
C	M20 Eastbound	
D	Castle Hill	

Roundabout Geometry

Arm	V - Approach road half - width (m)	E - Entry width (m)	I' - Effective flare length (m)	R - Entry radius (m)	D - Inscribed circle diameter (m)	PHI - Conflict (entry) angle (deg)	Exit only
A	5.25	7.52	10.0	72.0	37.5	44.0	
B	3.25	6.03	11.0	23.3	37.5	35.0	
C	5.27	10.71	39.2	24.8	37.5	42.0	
D	3.47	7.77	21.2	21.4	37.5	44.0	

Slope / Intercept / Capacity

Roundabout Slope and Intercept used in model

Arm	Final slope	Final intercept (PCU/hr)
A	0.696	1963
B	0.591	1435
C	0.829	2650
D	0.645	1758

The slope and intercept shown above include any corrections and adjustments.

Traffic Demand

Demand Set Details

ID	Scenario name	Time Period name	Traffic profile type	Start time (HH:mm)	Finish time (HH:mm)	Time segment length (min)	Run automatically
D1	Base	AM	ONE HOUR	07:45	09:15	15	9

Vehicle mix varies over turn	Vehicle mix varies over entry	Vehicle mix source	PCU Factor for a HV (PCU)
9	9	HV Percentages	2.00

Demand overview (Traffic)

Arm	Linked arm	Profile type	Use O-D data	Average Demand (Veh/hr)	Scaling Factor (%)
A		ONE HOUR	9	0	100.000
B		ONE HOUR	9	284	100.000
C		ONE HOUR	9	1002	100.000
D		ONE HOUR	9	6	100.000

Origin -Destination Data

Demand (Veh/hr)

		To				
		\$	%	&	'	
From	\$	0	0	0	0	0
	%	282	0	0	2	
	&	1	998	0	3	
	'	2	4	0	0	

Vehicle Mix

Heavy Vehicle Percentages

		To				
		\$	%	&	'	
From	\$	0	0	0	0	0
	%	6	0	0	50	
	&	0	3	0	33	
	'	0	25	0	0	

Results

Results Summary for whole modelled period

Arm	Max RFC	Max delay (s)	Max Queue (Veh)	Max LOS	Average Demand (Veh/hr)	Total Junction Arrivals (Veh)
A	0.00	0.00	0.0	A	0	0
B	0.23	3.47	0.3	A	261	391
C	0.48	3.00	0.9	A	919	1379
D	0.01	5.20	0.0	A	6	8

Main Results for each time segment

07:45 - 08:00

Arm	Total Demand (Veh/hr)	Junction Arrivals (Veh)	Circulating flow (Veh/hr)	Capacity (Veh/hr)	RFC	Throughput (Veh/hr)	Throughput (exit side) (Veh/hr)	Start queue (Veh)	End queue (Veh)	Delay (s)	LOS
A	0	0	753	1423	0.000	0	214	0.0	0.0	0.000	A
B	214	53	0	1350	0.158	213	753	0.0	0.2	3.164	A
C	754	189	213	2389	0.316	753	0	0.0	0.5	2.198	A
D	5	1	962	956	0.005	4	4	0.0	0.0	3.784	A

08:00 - 08:15

Arm	Total Demand (Veh/hr)	Junction Arrivals (Veh)	Circulating flow (Veh/hr)	Capacity (Veh/hr)	RFC	Throughput (Veh/hr)	Throughput (exit side) (Veh/hr)	Start queue (Veh)	End queue (Veh)	Delay (s)	LOS
A	0	0	900	1317	0.000	0	256	0.0	0.0	0.000	A
B	255	64	0	1350	0.189	255	900	0.2	0.2	3.287	A
C	901	225	255	2353	0.383	900	0	0.5	0.6	2.476	A
D	5	1	1151	847	0.006	5	4	0.0	0.0	4.275	A

08:15 - 08:30

Arm	Total Demand (Veh/hr)	Junction Arrivals (Veh)	Circulating flow (Veh/hr)	Capacity (Veh/hr)	RFC	Throughput (Veh/hr)	Throughput (exit side) (Veh/hr)	Start queue (Veh)	End queue (Veh)	Delay (s)	LOS
A	0	0	1102	1172	0.000	0	314	0.0	0.0	0.000	A
B	313	78	0	1350	0.232	312	1102	0.2	0.3	3.469	A
C	1103	276	312	2304	0.479	1102	0	0.6	0.9	2.993	A
D	7	2	1409	699	0.009	7	5	0.0	0.0	5.196	A

08:30 - 08:45

Arm	Total Demand (Veh/hr)	Junction Arrivals (Veh)	Circulating flow (Veh/hr)	Capacity (Veh/hr)	RFC	Throughput (Veh/hr)	Throughput (exit side) (Veh/hr)	Start queue (Veh)	End queue (Veh)	Delay (s)	LOS
A	0	0	1103	1171	0.000	0	314	0.0	0.0	0.000	A
B	313	78	0	1350	0.232	313	1103	0.3	0.3	3.469	A
C	1103	276	313	2304	0.479	1103	0	0.9	0.9	2.998	A
D	7	2	1410	698	0.009	7	6	0.0	0.0	5.202	A

08:45 - 09:00

Arm	Total Demand (Veh/hr)	Junction Arrivals (Veh)	Circulating flow (Veh/hr)	Capacity (Veh/hr)	RFC	Throughput (Veh/hr)	Throughput (exit side) (Veh/hr)	Start queue (Veh)	End queue (Veh)	Delay (s)	LOS
A	0	0	902	1316	0.000	0	256	0.0	0.0	0.000	A
B	255	64	0	1350	0.189	256	902	0.3	0.2	3.291	A
C	901	225	256	2352	0.383	902	0	0.9	0.6	2.483	A
D	5	1	1153	846	0.006	5	5	0.0	0.0	4.284	A

09:00 - 09:15

Arm	Total Demand (Veh/hr)	Junction Arrivals (Veh)	Circulating flow (Veh/hr)	Capacity (Veh/hr)	RFC	Throughput (Veh/hr)	Throughput (exit side) (Veh/hr)	Start queue (Veh)	End queue (Veh)	Delay (s)	LOS
A	0	0	755	1421	0.000	0	215	0.0	0.0	0.000	A
B	214	53	0	1350	0.158	214	755	0.2	0.2	3.170	A
C	754	189	214	2388	0.316	755	0	0.6	0.5	2.206	A
D	5	1	965	954	0.005	5	4	0.0	0.0	3.792	A

Base, PM

Data Errors and Warnings

Severity	Area	Item	Description
Warning	Geometry	Arm C - Roundabout Geometry	Effective flare length is over 30m, which is outside the normal range. Treat capacities with increasing caution.

Junction Network

Junctions

Junction	Name	Junction Type	Arm order	Junction Delay (s)	Junction LOS
1	untitled	Standard Roundabout	A, B, C, D	3.54	A

Junction Network Options

Driving side	Lighting
Left	Normal/unknown

Traffic Demand

Demand Set Details

ID	Scenario name	Time Period name	Traffic profile type	Start time (HH:mm)	Finish time (HH:mm)	Time segment length (min)	Run automatically
D2	Base	PM	ONE HOUR	16:30	18:00	15	9

Vehicle mix varies over turn	Vehicle mix varies over entry	Vehicle mix source	PCU Factor for a HV (PCU)
9	9	HV Percentages	2.00

Demand overview (Traffic)

Arm	Linked arm	Profile type	Use O-D data	Average Demand (Veh/hr)	Scaling Factor (%)
A		ONE HOUR	9	0	100.000
B		ONE HOUR	9	463	100.000
C		ONE HOUR	9	1019	100.000
D		ONE HOUR	9	12	100.000

Origin -Destination Data

Demand (Veh/hr)

From	To				
	\$	%	&	'	
	0	0	0	0	0
	460	0	0	3	
	3	1010	0	6	
	3	9	0	0	

Vehicle Mix

Heavy Vehicle Percentages

	To				
	A	B	C	D	
From	A	0	0	0	0
	B	1	0	0	0
	C	0	1	0	0
	D	0	0	0	0

Results

Results Summary for whole modelled period

Arm	Max RFC	Max delay (s)	Max Queue (Veh)	Max LOS	Average Demand (Veh/hr)	Total Junction Arrivals (Veh)
A	0.00	0.00	0.0	A	0	0
B	0.36	3.95	0.6	A	425	637
C	0.51	3.33	1.0	A	935	1403
D	0.02	5.23	0.0	A	11	17

Main Results for each time segment

16:30 - 16:45

Arm	Total Demand (Veh/hr)	Junction Arrivals (Veh)	Circulating flow (Veh/hr)	Capacity (Veh/hr)	RFC	Throughput (Veh/hr)	Throughput (exit side) (Veh/hr)	Start queue (Veh)	End queue (Veh)	Delay (s)	LOS
A	0	0	765	1425	0.000	0	350	0.0	0.0	0.000	A
B	349	87	0	1421	0.245	347	765	0.0	0.3	3.347	A
C	767	192	347	2336	0.328	765	0	0.0	0.5	2.288	A
D	9	2	1106	1038	0.009	9	7	0.0	0.0	3.499	A

16:45 - 17:00

Arm	Total Demand (Veh/hr)	Junction Arrivals (Veh)	Circulating flow (Veh/hr)	Capacity (Veh/hr)	RFC	Throughput (Veh/hr)	Throughput (exit side) (Veh/hr)	Start queue (Veh)	End queue (Veh)	Delay (s)	LOS
A	0	0	915	1319	0.000	0	419	0.0	0.0	0.000	A
B	416	104	0	1421	0.293	416	915	0.3	0.4	3.581	A
C	916	229	416	2279	0.402	915	0	0.5	0.7	2.637	A
D	11	3	1323	896	0.012	11	8	0.0	0.0	4.066	A

17:00 - 17:15

Arm	Total Demand (Veh/hr)	Junction Arrivals (Veh)	Circulating flow (Veh/hr)	Capacity (Veh/hr)	RFC	Throughput (Veh/hr)	Throughput (exit side) (Veh/hr)	Start queue (Veh)	End queue (Veh)	Delay (s)	LOS
A	0	0	1120	1175	0.000	0	512	0.0	0.0	0.000	A
B	510	127	0	1421	0.359	509	1120	0.4	0.6	3.944	A
C	1122	280	509	2202	0.509	1120	0	0.7	1.0	3.324	A
D	13	3	1620	703	0.019	13	10	0.0	0.0	5.220	A

17:15 - 17:30

Arm	Total Demand (Veh/hr)	Junction Arrivals (Veh)	Circulating flow (Veh/hr)	Capacity (Veh/hr)	RFC	Throughput (Veh/hr)	Throughput (exit side) (Veh/hr)	Start queue (Veh)	End queue (Veh)	Delay (s)	LOS
A	0	0	1122	1174	0.000	0	513	0.0	0.0	0.000	A
B	510	127	0	1421	0.359	510	1122	0.6	0.6	3.949	A
C	1122	280	510	2202	0.510	1122	0	1.0	1.0	3.333	A
D	13	3	1622	701	0.019	13	10	0.0	0.0	5.230	A

17:30 - 17:45

Arm	Total Demand (Veh/hr)	Junction Arrivals (Veh)	Circulating flow (Veh/hr)	Capacity (Veh/hr)	RFC	Throughput (Veh/hr)	Throughput (exit side) (Veh/hr)	Start queue (Veh)	End queue (Veh)	Delay (s)	LOS
A	0	0	918	1318	0.000	0	419	0.0	0.0	0.000	A
B	416	104	0	1421	0.293	417	918	0.6	0.4	3.585	A
C	916	229	417	2279	0.402	917	0	1.0	0.7	2.646	A
D	11	3	1326	894	0.012	11	8	0.0	0.0	4.076	A

17:45 - 18:00

Arm	Total Demand (Veh/hr)	Junction Arrivals (Veh)	Circulating flow (Veh/hr)	Capacity (Veh/hr)	RFC	Throughput (Veh/hr)	Throughput (exit side) (Veh/hr)	Start queue (Veh)	End queue (Veh)	Delay (s)	LOS
A	0	0	768	1423	0.000	0	351	0.0	0.0	0.000	A
B	349	87	0	1421	0.245	349	768	0.4	0.3	3.360	A
C	767	192	349	2335	0.329	768	0	0.7	0.5	2.297	A
D	9	2	1110	1035	0.009	9	7	0.0	0.0	3.508	A

F.25 J22_A20 Ashford Rd Stone St

Junctions 9
PICADY 9 - Priority Intersection Module
Version: 9.0.2.5947 © Copyright TRL Limited, 2017
For sales and distribution information, program advice and maintenance, contact TRL: +44 (0)1344 770558 software@trl.co.uk www.trlsoftware.co.uk
The users of this computer program for the solution of an engineering problem are in no way relieved of their responsibility for the correctness of the solution

Filename: J22_A20 Ashford Rd Stone St_Base Model.j9
Path: K:\UA008926 Otterpool\D-Calcs\Modelling\DM_it5\Appendix\Appendix Base Models\Picady\J22 A20 Ashford Rd - Stone St
Report generation date: 20/11/2018 15:55:51

- »Base, AM
- »Base, PM

Summary of junction performance

	AM				PM			
	Queue (Veh)	Delay (s)	RFC	LOS	Queue (Veh)	Delay (s)	RFC	LOS
	Base							
Stream B-AC	0.1	12.53	0.11	B	0.4	16.17	0.28	C
Stream C-AB	0.0	7.29	0.04	A	0.1	7.59	0.05	A

Values shown are the highest values encountered over all time segments. Delay is the maximum value of average delay per arriving vehicle.

File summary

File Description

Title	J22 Otterpool Park_Base Model
Location	A20 Ashford Rd - Stone St
Site number	
Date	08/08/2017
Version	
Status	Base
Identifier	
Client	
Jobnumber	
Enumerator	dma78191 [C8Z9W0G2]
Description	

Units

Distance units	Speed units	Traffic units input	Traffic units results	Flow units	Average delay units	Total delay units	Rate of delay units
m	kph	Veh	Veh	perHour	s	-Hour	perHour

Analysis Options

Vehicle length (m)	Calculate Queue Percentiles	Calculate detailed queueing delay	Calculate residual capacity	RFC Threshold	Average Delay threshold (s)	Queue threshold (PCU)
5.75				0.85	36.00	20.00

Demand Set Summary

ID	Scenario name	Time Period name	Description	Traffic profile type	Start time (HH:mm)	Finish time (HH:mm)	Time segment length (min)	Run automatically
D1	Base	AM	J22 Otterpool Park AM PEAK	ONE HOUR	07:45	09:15	15	9
D2	Base	PM	J22 Otterpool Park PM PEAK	ONE HOUR	16:45	18:15	15	9

Analysis Set Details

ID	Include in report	Network flow scaling factor (%)	Network capacity scaling factor (%)
A1	9	100.000	100.000

Base, AM

Data Errors and Warnings

No errors or warnings

Junction Network

Junctions

Junction	Name	Junction Type	Major road direction	Junction Delay (s)	Junction LOS
1	untitled	T-Junction	Two-way	0.34	A

Junction Network Options

Driving side	Lighting
Left	Normal/unknown

Arms

Arms

Arm	Name	Description	Arm type
A	A20 Ashford Road Westbound		Major
B	Stone Street		Minor
C	A20 Ashford Road Eastbound		Major

Major Arm Geometry

Arm	Width of carriageway (m)	Has kerbed central reserve	Width of kerbed central reserve (m)	Has right turn bay	Width for right turn (m)	Visibility for right turn (m)	Blocks?	Blocking queue (PCU)
C	8.38	9	2.71	9	2.70	97.0	9	1.00

Geometries for Arm C are measured opposite Arm B. Geometries for Arm A (if relevant) are measured opposite Arm D.

Minor Arm Geometry

Arm	Minor arm type	Lane width (m)	Visibility to left (m)	Visibility to right (m)
B	One lane	2.40	78	108

Slope / Intercept / Capacity

Priority Intersection Slopes and Intercepts

Junction	Stream	Intercept (Veh/hr)	Slope for A-B	Slope for A-C	Slope for C-A	Slope for C-B
1	B-A	555	0.086	0.216	0.136	0.309
1	B-C	650	0.089	0.226	-	-
1	C-B	664	0.231	0.231	-	-

The slopes and intercepts shown above do NOT include any corrections or adjustments.

Streams may be combined, in which case capacity will be adjusted.

Values are shown for the first time segment only; they may differ for subsequent time segments.

Traffic Demand

Demand Set Details

ID	Scenario name	Time Period name	Description	Traffic profile type	Start time (HH:mm)	Finish time (HH:mm)	Time segment length (min)	Run automatically
D1	Base	AM	J22 Otterpool Park AM PEAK	ONE HOUR	07:45	09:15	15	9

Vehicle mix varies over turn	Vehicle mix varies over entry	Vehicle mix source	PCU Factor for a HV (PCU)
9	9	HV Percentages	2.00

Demand overview (Traffic)

Arm	Linked arm	Profile type	Use O-D data	Average Demand (Veh/hr)	Scaling Factor (%)
A		ONE HOUR	9	662	100.000
B		ONE HOUR	9	31	100.000
C		ONE HOUR	9	724	100.000

Origin -Destination Data

Demand (Veh/hr)

	To			
		\$	%	&
From	\$	0	26	636
	%	20	0	11
	&	707	17	0

Vehicle Mix

Heavy Vehicle Percentages

	To			
		\$	%	&
From	\$	0	0	8
	%	0	0	0
	&	5	0	0

Results

Results Summary for whole modelled period

Stream	Max RFC	Max delay (s)	Max Queue (Veh)	Max LOS	Average Demand (Veh/hr)	Total Junction Arrivals (Veh)
B-AC	0.11	12.53	0.1	B	28	43
C-AB	0.04	7.29	0.0	A	16	24
C-A					648	972
A-B					24	36
A-C					584	875

Main Results for each time segment

07:45 - 08:00

Stream	Total Demand (Veh/hr)	Junction Arrivals (Veh)	Capacity (Veh/hr)	RFC	Throughput (Veh/hr)	Start queue (Veh)	End queue (Veh)	Delay (s)	LOS
B-AC	23	6	408	0.057	23	0.0	0.1	9.341	A
C-AB	13	3	553	0.024	13	0.0	0.0	6.664	A
C-A	532	133			532				
A-B	20	5			20				
A-C	479	120			479				

08:00 - 08:15

Stream	Total Demand (Veh/hr)	Junction Arrivals (Veh)	Capacity (Veh/hr)	RFC	Throughput (Veh/hr)	Start queue (Veh)	End queue (Veh)	Delay (s)	LOS
B-AC	28	7	372	0.075	28	0.1	0.1	10.447	B
C-AB	16	4	535	0.030	16	0.0	0.0	6.928	A
C-A	635	159			635				
A-B	23	6			23				
A-C	572	143			572				

08:15 - 08:30

Stream	Total Demand (Veh/hr)	Junction Arrivals (Veh)	Capacity (Veh/hr)	RFC	Throughput (Veh/hr)	Start queue (Veh)	End queue (Veh)	Delay (s)	LOS
B-AC	34	9	321	0.106	34	0.1	0.1	12.517	B
C-AB	20	5	513	0.039	20	0.0	0.0	7.293	A
C-A	777	194			777				
A-B	29	7			29				
A-C	700	175			700				

08:30 - 08:45

Stream	Total Demand (Veh/hr)	Junction Arrivals (Veh)	Capacity (Veh/hr)	RFC	Throughput (Veh/hr)	Start queue (Veh)	End queue (Veh)	Delay (s)	LOS
B-AC	34	9	321	0.106	34	0.1	0.1	12.530	B
C-AB	20	5	513	0.039	20	0.0	0.0	7.293	A
C-A	777	194			777				
A-B	29	7			29				
A-C	700	175			700				

08:45 - 09:00

Stream	Total Demand (Veh/hr)	Junction Arrivals (Veh)	Capacity (Veh/hr)	RFC	Throughput (Veh/hr)	Start queue (Veh)	End queue (Veh)	Delay (s)	LOS
B-AC	28	7	372	0.075	28	0.1	0.1	10.462	B
C-AB	16	4	536	0.030	16	0.0	0.0	6.930	A
C-A	635	159			635				
A-B	23	6			23				
A-C	572	143			572				

09:00 - 09:15

Stream	Total Demand (Veh/hr)	Junction Arrivals (Veh)	Capacity (Veh/hr)	RFC	Throughput (Veh/hr)	Start queue (Veh)	End queue (Veh)	Delay (s)	LOS
B-AC	23	6	408	0.057	23	0.1	0.1	9.358	A
C-AB	13	3	553	0.024	13	0.0	0.0	6.668	A
C-A	532	133			532				
A-B	20	5			20				
A-C	479	120			479				

Base, PM

Data Errors and Warnings

No errors or warnings

Junction Network

Junctions

Junction	Name	Junction Type	Major road direction	Junction Delay (s)	Junction LOS
1	untitled	T-Junction	Two-way	0.90	A

Junction Network Options

Driving side	Lighting
Left	Normal/unknown

Traffic Demand

Demand Set Details

ID	Scenario name	Time Period name	Description	Traffic profile type	Start time (HH:mm)	Finish time (HH:mm)	Time segment length (min)	Run automatically
D2	Base	PM	J22 Otterpool Park PM PEAK	ONE HOUR	16:45	18:15	15	9

Vehicle mix varies over turn	Vehicle mix varies over entry	Vehicle mix source	PCU Factor for a HV (PCU)
9	9	HV Percentages	2.00

Demand overview (Traffic)

Arm	Linked arm	Profile type	Use O-D data	Average Demand (Veh/hr)	Scaling Factor (%)
A		ONE HOUR	9	767	100.000
B		ONE HOUR	9	77	100.000
C		ONE HOUR	9	693	100.000

Origin -Destination Data

Demand (Veh/hr)

	To			
		\$	%	&
From	\$	0	29	738
	%	49	0	28
	&	671	22	0

Vehicle Mix

Heavy Vehicle Percentages

	To			
		\$	%	&
From	\$	0	0	4
	%	0	0	0
	&	3	0	0

Results

Results Summary for whole modelled period

Stream	Max RFC	Max delay (s)	Max Queue (Veh)	Max LOS	Average Demand (Veh/hr)	Total Junction Arrivals (Veh)
B-AC	0.28	16.17	0.4	C	71	106
C-AB	0.05	7.59	0.1	A	21	32
C-A					615	922
A-B					27	40
A-C					677	1016

Main Results for each time segment

16:45 - 17:00

Stream	Total Demand (Veh/hr)	Junction Arrivals (Veh)	Capacity (Veh/hr)	RFC	Throughput (Veh/hr)	Start queue (Veh)	End queue (Veh)	Delay (s)	LOS
B-AC	58	14	399	0.145	57	0.0	0.2	10.515	B
C-AB	17	4	542	0.031	17	0.0	0.0	6.855	A
C-A	505	126			505				
A-B	22	5			22				
A-C	556	139			556				

17:00 - 17:15

Stream	Total Demand (Veh/hr)	Junction Arrivals (Veh)	Capacity (Veh/hr)	RFC	Throughput (Veh/hr)	Start queue (Veh)	End queue (Veh)	Delay (s)	LOS
B-AC	69	17	361	0.192	69	0.2	0.2	12.311	B
C-AB	21	5	523	0.040	21	0.0	0.0	7.165	A
C-A	602	151			602				
A-B	26	7			26				
A-C	663	166			663				

17:15 - 17:30

Stream	Total Demand (Veh/hr)	Junction Arrivals (Veh)	Capacity (Veh/hr)	RFC	Throughput (Veh/hr)	Start queue (Veh)	End queue (Veh)	Delay (s)	LOS
B-AC	85	21	307	0.276	84	0.2	0.4	16.090	C
C-AB	26	7	501	0.052	26	0.0	0.1	7.585	A
C-A	737	184			737				
A-B	32	8			32				
A-C	813	203			813				

17:30 - 17:45

Stream	Total Demand (Veh/hr)	Junction Arrivals (Veh)	Capacity (Veh/hr)	RFC	Throughput (Veh/hr)	Start queue (Veh)	End queue (Veh)	Delay (s)	LOS
B-AC	85	21	307	0.276	85	0.4	0.4	16.167	C
C-AB	26	7	501	0.052	26	0.1	0.1	7.589	A
C-A	737	184			737				
A-B	32	8			32				
A-C	813	203			813				

17:45 - 18:00

Stream	Total Demand (Veh/hr)	Junction Arrivals (Veh)	Capacity (Veh/hr)	RFC	Throughput (Veh/hr)	Start queue (Veh)	End queue (Veh)	Delay (s)	LOS
B-AC	69	17	361	0.192	70	0.4	0.2	12.379	B
C-AB	21	5	523	0.040	21	0.1	0.0	7.170	A
C-A	602	151			602				
A-B	26	7			26				
A-C	663	166			663				

18:00 - 18:15

Stream	Total Demand (Veh/hr)	Junction Arrivals (Veh)	Capacity (Veh/hr)	RFC	Throughput (Veh/hr)	Start queue (Veh)	End queue (Veh)	Delay (s)	LOS
B-AC	58	14	399	0.145	58	0.2	0.2	10.575	B
C-AB	17	4	542	0.031	17	0.0	0.0	6.861	A
C-A	505	126			505				
A-B	22	5			22				
A-C	556	139			556				

F.26 J23_M20 Junction 9

Full Input Data And Results
Full Input Data And Results

User and Project Details

Project:	Otterpool Park
Title:	J23 M20 Junction 9
Location:	M20 - Junction 9
Additional detail:	
File name:	J23_M20_Junction 9_Base Model.lsg3x
Author:	Diego Moreno-Sosa
Company:	ARCADIS UK
Address:	

Network Layout Diagram

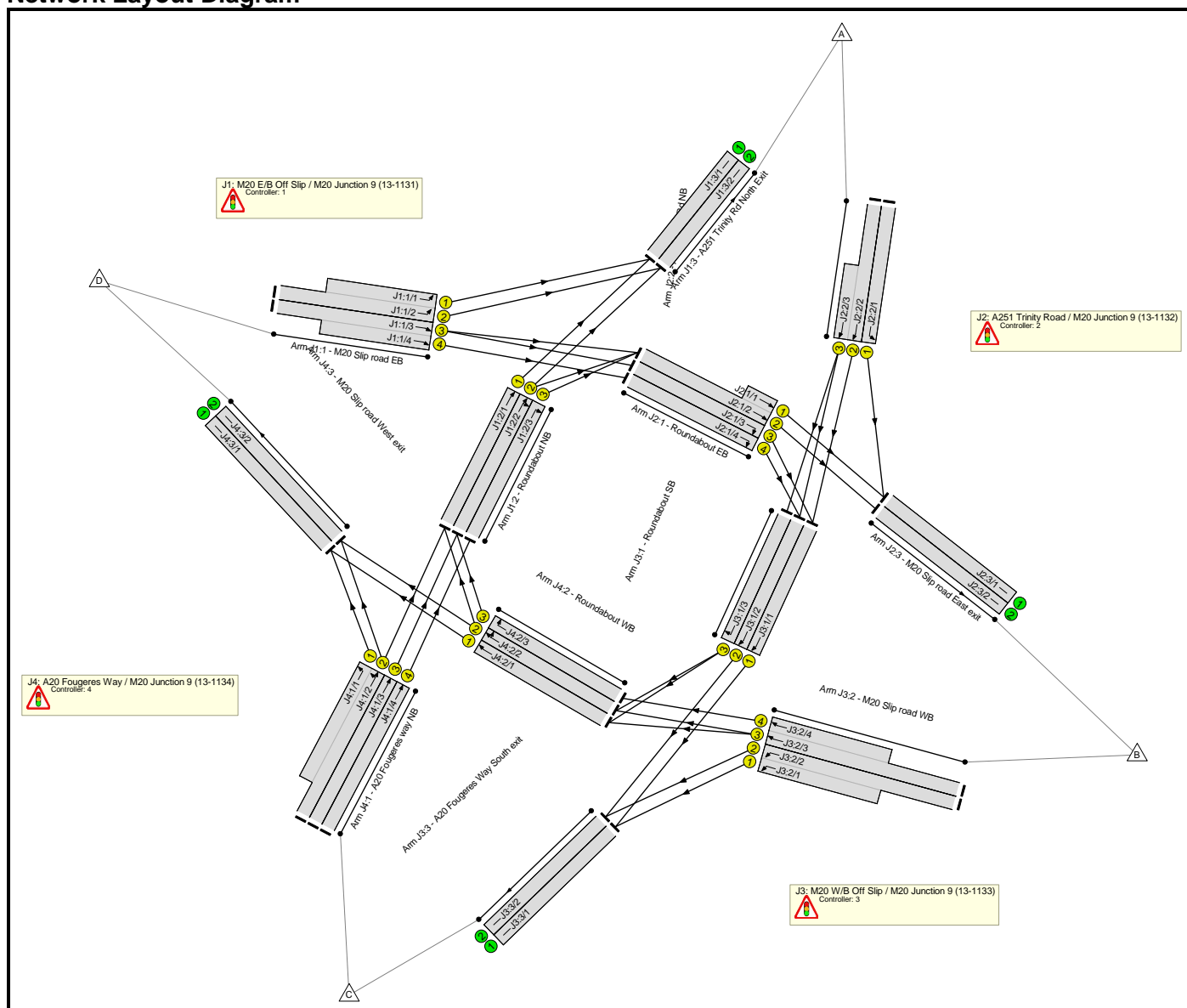

Full Input Data And Results

C1 - 13/1131

Phase Input Data

Phase Name	Phase Type	Assoc. Phase	Street Min	Cont Min
A	Traffic		7	7
B	Traffic		7	7

Phase Intergreens Matrix

	Starting Phase	
Terminating Phase	A	B
	A	7
	B	7

Phases in Stage

Stage No.	Phases in Stage
1	A
2	B

Stage Diagram

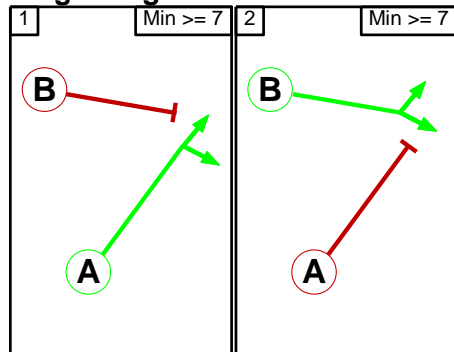

Phase Delays

Term. Stage	Start Stage	Phase	Type	Value	Cont value
There are no Phase Delays defined					

C2 - 13/1132

Phase Input Data

Phase Name	Phase Type	Assoc. Phase	Street Min	Cont Min
A	Traffic		7	7
B	Traffic		7	7

Full Input Data And Results

Phase Intergreens Matrix

	Starting Phase		
		A	B
Terminating Phase	A		5
	B	7	

Phases in Stage

Stage No.	Phases in Stage
1	A
2	B

Stage Diagram

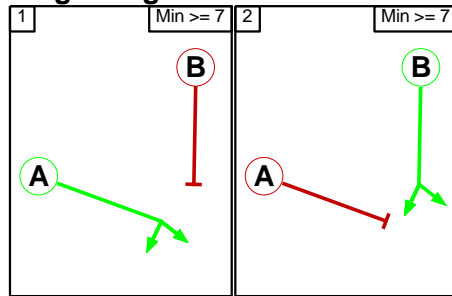

Phase Delays

Term. Stage	Start Stage	Phase	Type	Value	Cont value
There are no Phase Delays defined					

C3 - 13/1133

Phase Input Data

Phase Name	Phase Type	Assoc. Phase	Street Min	Cont Min
A	Traffic		7	7
B	Traffic		7	7

Phase Intergreens Matrix

	Starting Phase		
		A	B
Terminating Phase	A		7
	B	7	

Phases in Stage

Stage No.	Phases in Stage
1	A
2	B

Full Input Data And Results

Stage Diagram

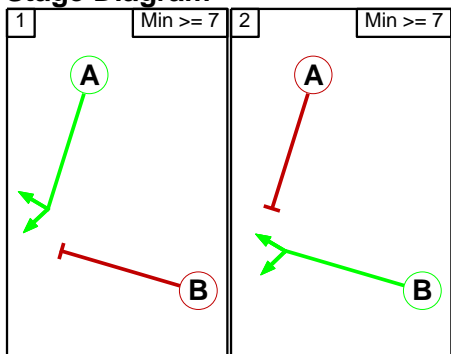

Phase Delays

Term. Stage	Start Stage	Phase	Type	Value	Cont value
There are no Phase Delays defined					

C4 - 13/1134

Phase Input Data

Phase Name	Phase Type	Assoc. Phase	Street Min	Cont Min
A	Traffic		7	7
B	Traffic		7	7

Phase Intergreens Matrix

Terminating Phase	Starting Phase	
	A	B
	A	5
B	7	

Phases in Stage

Stage No.	Phases in Stage
1	A
2	B

Stage Diagram

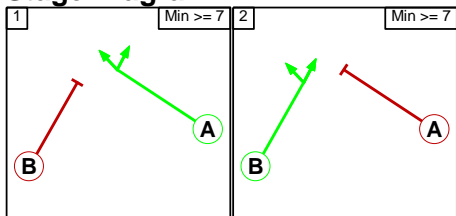

Phase Delays

Term. Stage	Start Stage	Phase	Type	Value	Cont value
There are no Phase Delays defined					

Full Input Data And Results

Traffic Flows, Desired

Scenario 1: 'AM PEAK' (FG1: 'AM PEAK', Plan 1: 'Network Control Plan 1')

Desired Flow :

		Destination				
		A	B	C	D	Tot.
Origin	A	0	369	488	147	1004
	B	633	0	766	0	1399
	C	621	603	0	601	1825
	D	223	2	605	0	830
	Tot.	1477	974	1859	748	5058

Scenario 2: 'PM PEAK' (FG2: 'PM PEAK', Plan 1: 'Network Control Plan 1')

Desired Flow :

		Destination				
		A	B	C	D	Tot.
Origin	A	0	653	783	151	1587
	B	492	0	554	0	1046
	C	493	669	0	507	1669
	D	171	0	793	0	964
	Tot.	1156	1322	2130	658	5266

Scenario 1: 'AM PEAK' (FG1: 'AM PEAK', Plan 1: 'Network Control Plan 1')

C1 - 13/1131

Stage Sequence Diagram

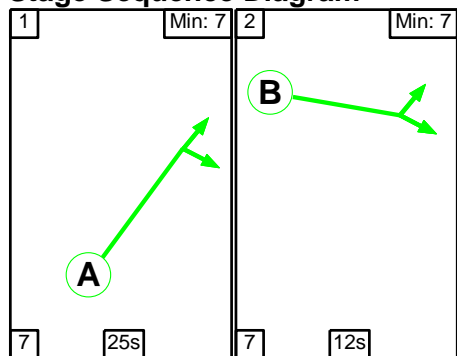

Stage Timings

Stage	1	2
Duration	25	12
Change Point	0	32

Signal Timings Diagram

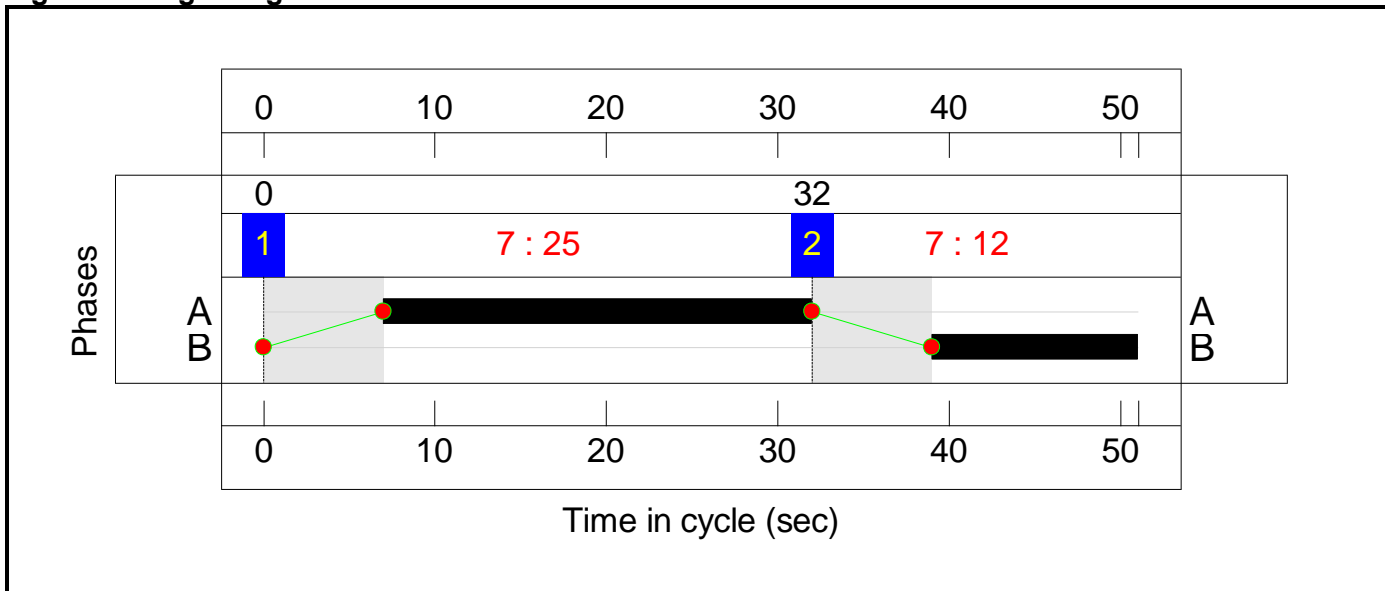

C2 - 13/1132

Stage Sequence Diagram

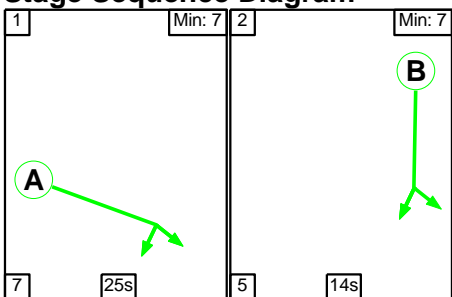

Stage Timings

Stage	1	2
Duration	25	14
Change Point	0	32

Signal Timings Diagram

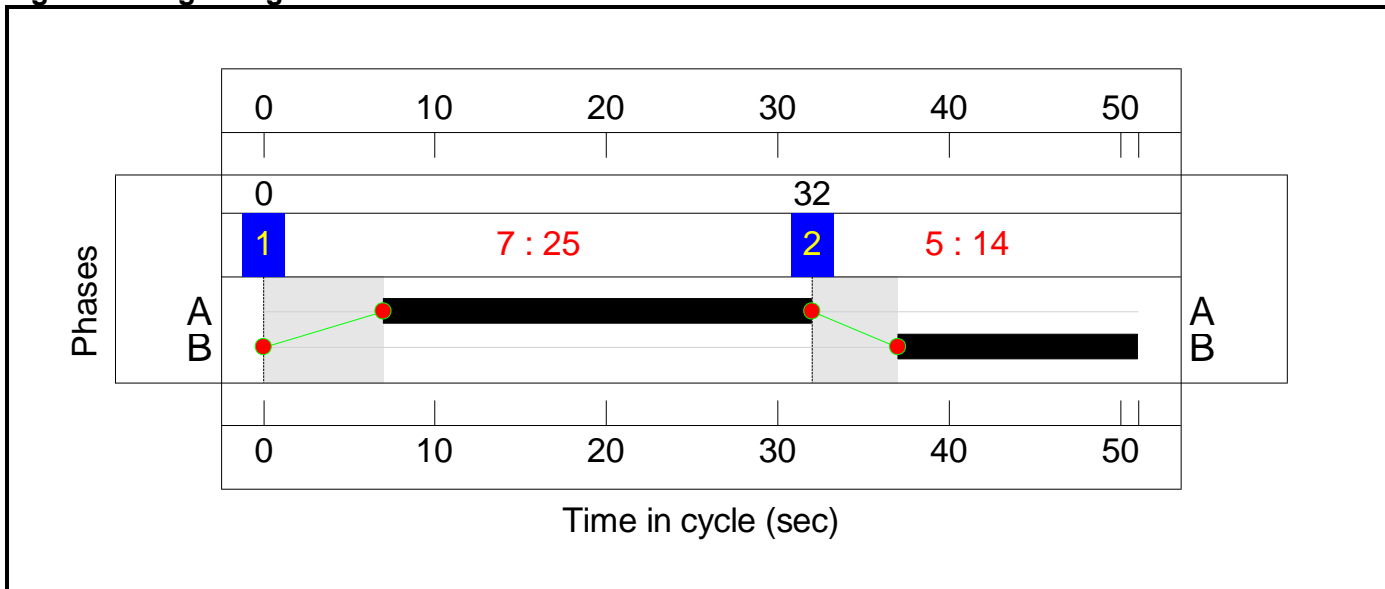

C3 - 13/1133

Stage Sequence Diagram

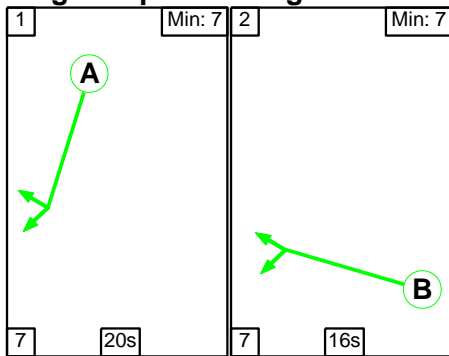

Stage Timings

Stage	1	2
Duration	20	16
Change Point	0	27

Signal Timings Diagram

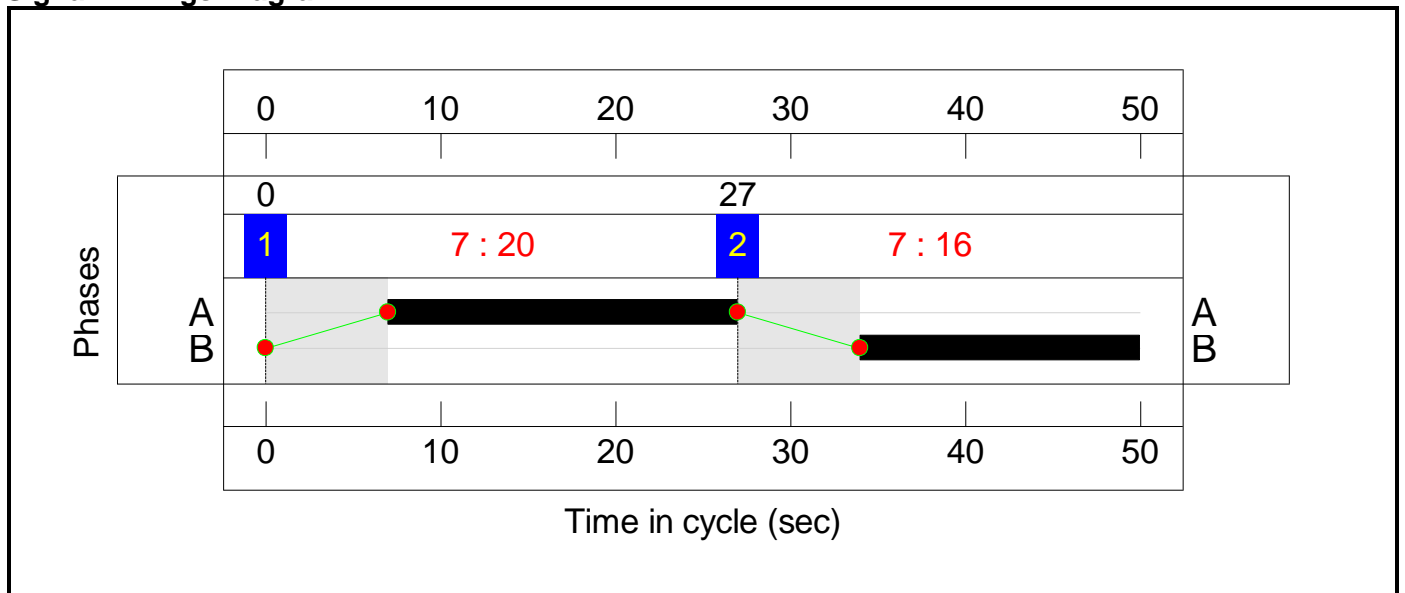

C4 - 13/1134

Stage Sequence Diagram

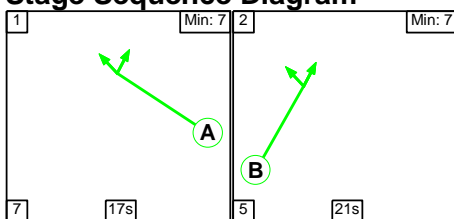

Stage Timings

Stage	1	2
Duration	17	21
Change Point	0	24

Signal Timings Diagram

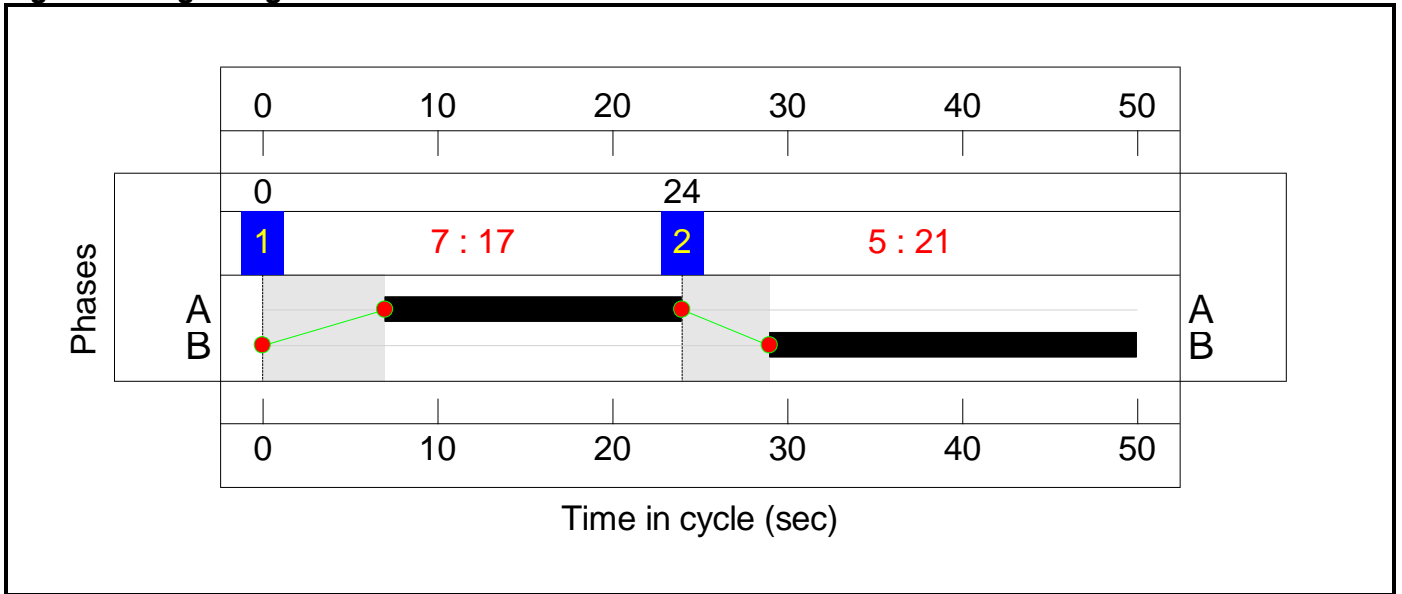

Full Input Data And Results
Network Layout Diagram

Full Input Data And Results

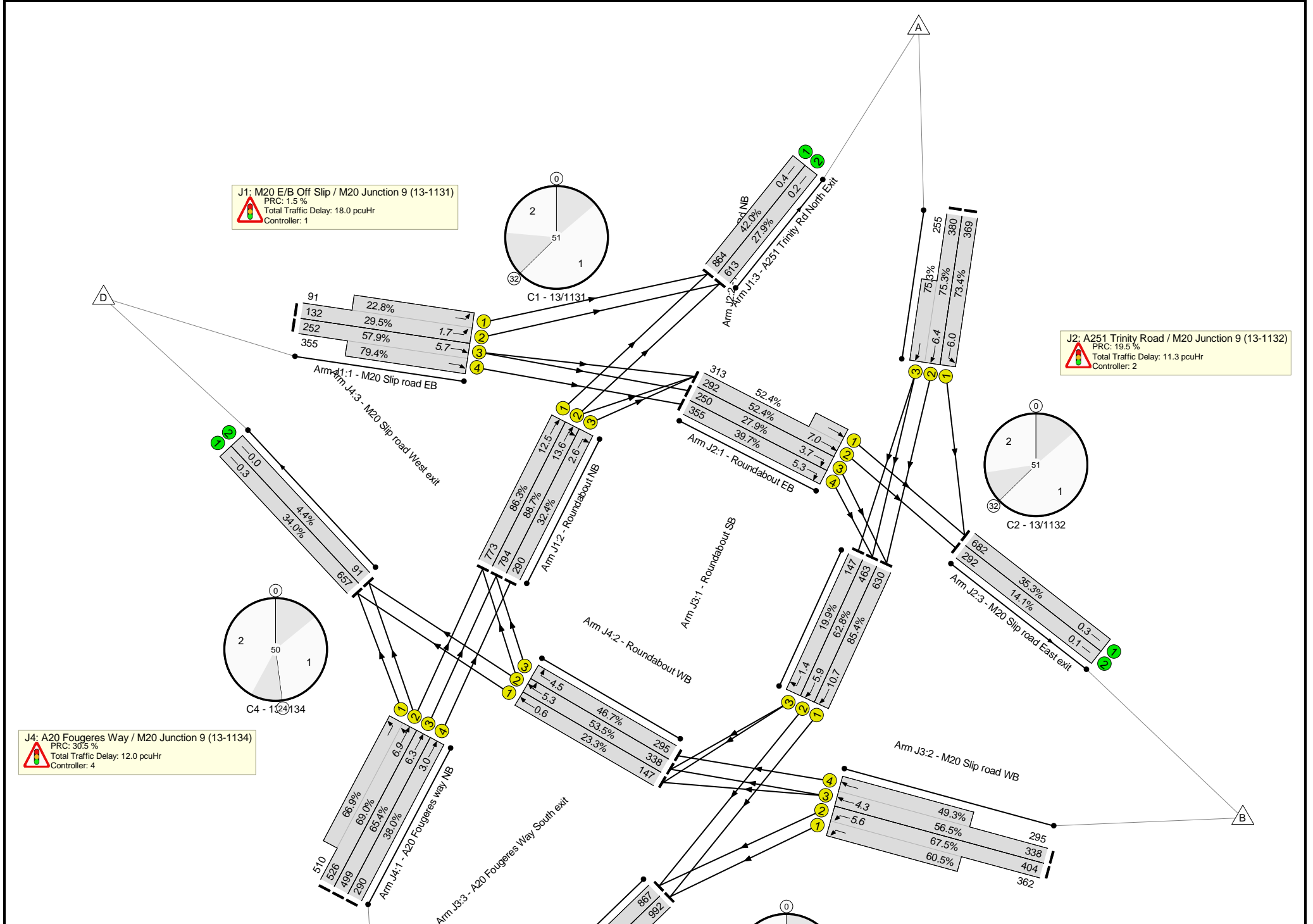

Full Input Data And Results

Full Input Data And Results

Network Results

Scenario 1: 'AM PEAK' (FG1: 'AM PEAK', Plan 1: 'Network Control Plan 1')

Item	Lane Description	Lane Type	Total Green (s)	Arrow Green (s)	Demand Flow (pcu)	Sat Flow (pcu/Hr)	Capacity (pcu)	Deg Sat (%)	Arriving (pcu)
Network: J23 M20 Junction 9	-	-	-	-	-	-	-	88.7%	-
J1: M20 E/B Off Slip / M20 Junction 9 (13-1131)	-	-	-	-	-	-	-	88.7%	-
1/2+1/1	M20 Slip road EB Left	U	12	-	223	1754:1754	447+400	29.5 : 22.8%	223
1/3+1/4	M20 Slip road EB Ahead	U	12	-	607	1754:1754	435+447	57.9 : 79.4%	607
2/1	Roundabout NB Ahead	U	25	-	773	1756	895	86.3%	773
2/2	Roundabout NB Right Ahead	U	25	-	794	1756	895	88.7%	794
2/3	Roundabout NB Right	U	25	-	290	1756	895	32.4%	290
3/1	A251 Trinity Rd North Exit	U	-	-	864	2055	2055	42.0%	864
3/2	A251 Trinity Rd North Exit	U	-	-	613	2195	2195	27.9%	613
J2: A251 Trinity Road / M20 Junction 9 (13-1132)	-	-	-	-	-	-	-	75.3%	-
1/2+1/1	Roundabout EB Ahead	U	25	-	605	1756:1756	557+597	52.4 : 52.4%	605
1/3	Roundabout EB Right	U	25	-	250	1756	895	27.9%	250
1/4	Roundabout EB Right	U	25	-	355	1756	895	39.7%	355
2/1	A251 Trinity Rd NB Left	U	14	-	369	1709	503	73.4%	369
2/2+2/3	A251 Trinity Rd NB Ahead	U	14	-	635	1715:1715	504+338	75.3 : 75.3%	635
3/1	M20 Slip road East exit	U	-	-	682	1932	1932	35.3%	682
3/2	M20 Slip road East exit	U	-	-	292	2072	2072	14.1%	292
J3: M20 W/B Off Slip / M20 Junction 9 (13-1133)	-	-	-	-	-	-	-	85.4%	-

Full Input Data And Results

1/1	Roundabout SB Ahead	U	20	-	630	1756	738	85.4%	630
1/2	Roundabout SB Ahead	U	20	-	463	1756	738	62.8%	463
1/3	Roundabout SB Right	U	20	-	147	1756	738	19.9%	147
2/2+2/1	M20 Slip road WB Left	U	16	-	766	1760:1760	598+598	67.5 : 60.5%	766
2/3+2/4	M20 Slip road WB Ahead	U	16	-	633	1760:1760	598+598	56.5 : 49.3%	633
3/1	A20 Fougères Way South exit	U	-	-	992	1937	1937	51.2%	992
3/2	A20 Fougères Way South exit	U	-	-	867	2077	2077	41.7%	867
J4: A20 Fougères Way / M20 Junction 9 (13-1134)	-	-	-	-	-	-	-	69.0%	-
1/2+1/1	A20 Fougères way NB Ahead Left	U	21	-	1036	1733:1733	763+763	69.0 : 66.9%	1036
1/3	A20 Fougères way NB Ahead	U	21	-	499	1733	763	65.4%	499
1/4	A20 Fougères way NB Ahead	U	21	-	290	1733	763	38.0%	290
2/1	Roundabout WB Ahead	U	17	-	147	1756	632	23.3%	147
2/2	Roundabout WB Right Ahead	U	17	-	338	1756	632	53.5%	338
2/3	Roundabout WB Right	U	17	-	295	1756	632	46.7%	295
3/1	M20 Slip road West exit	U	-	-	657	1932	1932	34.0%	657
3/2	M20 Slip road West exit	U	-	-	91	2072	2072	4.4%	91

Full Input Data And Results

Item	Leaving (pcu)	Turners In Intergreen (pcu)	Uniform Delay (pcuHr)	Rand + Oversat Delay (pcuHr)	Total Delay (pcuHr)	Av. Delay Per PCU (s/pcu)	Max. Back of Uniform Queue (pcu)	Rand + Oversat Queue (pcu)	Mean Max Queue (pcu)
Network: J23 M20 Junction 9	-	0	34.0	22.8	56.8	-	-	-	-
J1: M20 E/B Off Slip / M20 Junction 9 (13-1131)	-	0	9.3	8.7	18.0	-	-	-	-
1/2+1/1	223	-	0.9	0.2	1.1	18.1	1.5	0.2	1.7
1/3+1/4	607	-	2.9	1.1	4.0	23.7	4.6	1.1	5.7
2/1	773	-	2.4	3.0	5.4	25.0	9.4	3.0	12.5
2/2	794	-	2.5	3.7	6.1	27.8	9.9	3.7	13.6
2/3	290	-	0.6	0.2	0.8	10.3	2.3	0.2	2.6
3/1	864	-	0.0	0.4	0.4	1.5	0.0	0.4	0.4
3/2	613	-	0.0	0.2	0.2	1.1	0.0	0.2	0.2
J2: A251 Trinity Road / M20 Junction 9 (13-1132)	-	0	7.0	4.3	11.3	-	-	-	-
1/2+1/1	605	-	0.8	0.5	1.3	7.9	6.5	0.5	7.0
1/3	250	-	0.7	0.2	0.9	13.3	3.5	0.2	3.7
1/4	355	-	1.1	0.3	1.4	14.1	5.0	0.3	5.3
2/1	369	-	1.7	1.4	3.0	29.4	4.6	1.4	6.0
2/2+2/3	635	-	2.8	1.5	4.3	24.3	4.9	1.5	6.4
3/1	682	-	0.0	0.3	0.3	1.4	0.0	0.3	0.3
3/2	292	-	0.0	0.1	0.1	1.0	0.0	0.1	0.1
J3: M20 W/B Off Slip / M20 Junction 9 (13-1133)	-	0	9.4	6.1	15.5	-	-	-	-
1/1	630	-	2.3	2.8	5.1	29.0	7.9	2.8	10.7
1/2	463	-	1.5	0.8	2.3	17.9	5.0	0.8	5.9
1/3	147	-	0.4	0.1	0.5	12.3	1.3	0.1	1.4
2/2+2/1	766	-	3.0	0.9	3.9	18.1	4.7	0.9	5.6
2/3+2/4	633	-	2.3	0.6	2.9	16.5	3.8	0.6	4.3
3/1	992	-	0.0	0.5	0.5	1.9	0.0	0.5	0.5
3/2	867	-	0.0	0.4	0.4	1.5	0.0	0.4	0.4

Full Input Data And Results

J4: A20 Fougères Way / M20 Junction 9 (13-1134)	-	0	8.2	3.7	12.0	-	-	-	-																																			
1/2+1/1	1036	-	3.2	1.1	4.3	14.9	5.8	1.1	6.9																																			
1/3	499	-	1.5	0.9	2.5	17.8	5.4	0.9	6.3																																			
1/4	290	-	0.8	0.3	1.1	13.2	2.7	0.3	3.0																																			
2/1	147	-	0.3	0.2	0.4	9.9	0.5	0.2	0.6																																			
2/2	338	-	1.3	0.6	1.9	20.3	4.7	0.6	5.3																																			
2/3	295	-	1.1	0.4	1.6	19.4	4.1	0.4	4.5																																			
3/1	657	-	0.0	0.3	0.3	1.4	0.0	0.3	0.3																																			
3/2	91	-	0.0	0.0	0.0	0.9	0.0	0.0	0.0																																			
<table border="0"> <tr> <td>C1 - 13/1131</td> <td>PRC for Signalled Lanes (%):</td> <td>1.5</td> <td>Total Delay for Signalled Lanes (pcuHr):</td> <td>17.44</td> <td>Cycle Time (s):</td> <td>51</td> </tr> <tr> <td>C2 - 13/1132</td> <td>PRC for Signalled Lanes (%):</td> <td>19.5</td> <td>Total Delay for Signalled Lanes (pcuHr):</td> <td>10.94</td> <td>Cycle Time (s):</td> <td>51</td> </tr> <tr> <td>C3 - 13/1133</td> <td>PRC for Signalled Lanes (%):</td> <td>5.4</td> <td>Total Delay for Signalled Lanes (pcuHr):</td> <td>14.64</td> <td>Cycle Time (s):</td> <td>50</td> </tr> <tr> <td>C4 - 13/1134</td> <td>PRC for Signalled Lanes (%):</td> <td>30.5</td> <td>Total Delay for Signalled Lanes (pcuHr):</td> <td>11.71</td> <td>Cycle Time (s):</td> <td>50</td> </tr> <tr> <td></td> <td>PRC Over All Lanes (%):</td> <td>1.5</td> <td>Total Delay Over All Lanes(pcuHr):</td> <td>56.80</td> <td></td> <td></td> </tr> </table>										C1 - 13/1131	PRC for Signalled Lanes (%):	1.5	Total Delay for Signalled Lanes (pcuHr):	17.44	Cycle Time (s):	51	C2 - 13/1132	PRC for Signalled Lanes (%):	19.5	Total Delay for Signalled Lanes (pcuHr):	10.94	Cycle Time (s):	51	C3 - 13/1133	PRC for Signalled Lanes (%):	5.4	Total Delay for Signalled Lanes (pcuHr):	14.64	Cycle Time (s):	50	C4 - 13/1134	PRC for Signalled Lanes (%):	30.5	Total Delay for Signalled Lanes (pcuHr):	11.71	Cycle Time (s):	50		PRC Over All Lanes (%):	1.5	Total Delay Over All Lanes(pcuHr):	56.80		
C1 - 13/1131	PRC for Signalled Lanes (%):	1.5	Total Delay for Signalled Lanes (pcuHr):	17.44	Cycle Time (s):	51																																						
C2 - 13/1132	PRC for Signalled Lanes (%):	19.5	Total Delay for Signalled Lanes (pcuHr):	10.94	Cycle Time (s):	51																																						
C3 - 13/1133	PRC for Signalled Lanes (%):	5.4	Total Delay for Signalled Lanes (pcuHr):	14.64	Cycle Time (s):	50																																						
C4 - 13/1134	PRC for Signalled Lanes (%):	30.5	Total Delay for Signalled Lanes (pcuHr):	11.71	Cycle Time (s):	50																																						
	PRC Over All Lanes (%):	1.5	Total Delay Over All Lanes(pcuHr):	56.80																																								

Full Input Data And Results

Scenario 2: 'PM PEAK' (FG2: 'PM PEAK', Plan 1: 'Network Control Plan 1')

Item	Lane Description	Lane Type	Total Green (s)	Arrow Green (s)	Demand Flow (pcu)	Sat Flow (pcu/Hr)	Capacity (pcu)	Deg Sat (%)	Arriving (pcu)
Network: J23 M20 Junction 9	-	-	-	-	-	-	-	92.6%	-
J1: M20 E/B Off Slip / M20 Junction 9 (13-1131)	-	-	-	-	-	-	-	91.3%	-
1/2+1/1	M20 Slip road EB Left	U	16	-	171	1754:1754	459+334	21.6 : 21.6%	171
1/3+1/4	M20 Slip road EB Ahead	U	16	-	793	1754:1754	459+459	81.5 : 91.3%	793
2/1	Roundabout NB Ahead	U	35	-	643	1756	973	66.1%	643
2/2	Roundabout NB Right Ahead	U	35	-	624	1756	973	64.2%	624
2/3	Roundabout NB Right	U	35	-	387	1756	973	39.8%	387
3/1	A251 Trinity Rd North Exit	U	-	-	715	2055	2055	34.8%	715
3/2	A251 Trinity Rd North Exit	U	-	-	441	2195	2195	20.1%	441
J2: A251 Trinity Road / M20 Junction 9 (13-1132)	-	-	-	-	-	-	-	92.0%	-
1/2+1/1	Roundabout EB Ahead	U	27	-	669	1756:1756	532+388	72.8 : 72.8%	669
1/3	Roundabout EB Right	U	27	-	374	1756	756	49.4%	374
1/4	Roundabout EB Right	U	27	-	419	1756	756	55.4%	419
2/1	A251 Trinity Rd NB Left	U	26	-	653	1709	710	92.0%	653
2/2+2/3	A251 Trinity Rd NB Ahead	U	26	-	934	1715:1715	587+492	86.6 : 86.6%	934
3/1	M20 Slip road East exit	U	-	-	935	1932	1932	48.4%	935
3/2	M20 Slip road East exit	U	-	-	387	2072	2072	18.7%	387
J3: M20 W/B Off Slip / M20 Junction 9 (13-1133)	-	-	-	-	-	-	-	92.6%	-
1/1	Roundabout SB Ahead	U	31	-	882	1756	952	92.6%	882

Full Input Data And Results

1/2	Roundabout SB Ahead	U	31	-	694	1756	952	72.9%	694
1/3	Roundabout SB Right	U	31	-	151	1756	952	15.9%	151
2/2+2/1	M20 Slip road WB Left	U	14	-	554	1760:1760	447+447	67.0 : 56.8%	554
2/3+2/4	M20 Slip road WB Ahead	U	14	-	492	1760:1760	447+447	53.9 : 56.1%	492
3/1	A20 Fougères Way South exit	U	-	-	1136	1937	1937	58.6%	1136
3/2	A20 Fougères Way South exit	U	-	-	994	2077	2077	47.9%	994
J4: A20 Fougères Way / M20 Junction 9 (13-1134)	-	-	-	-	-	-	-	63.2%	-
1/2+1/1	A20 Fougères way NB Ahead Left	U	26	-	909	1733:1733	676+793	60.3 : 63.2%	909
1/3	A20 Fougères way NB Ahead	U	26	-	373	1733	793	47.0%	373
1/4	A20 Fougères way NB Ahead	U	26	-	387	1733	793	48.8%	387
2/1	Roundabout WB Ahead	U	21	-	151	1756	655	23.1%	151
2/2	Roundabout WB Right Ahead	U	21	-	241	1756	655	36.8%	241
2/3	Roundabout WB Right	U	21	-	251	1756	655	38.3%	251
3/1	M20 Slip road West exit	U	-	-	652	1932	1932	33.7%	652
3/2	M20 Slip road West exit	U	-	-	6	2072	2072	0.3%	6

Full Input Data And Results

Item	Leaving (pcu)	Turners In Intergreen (pcu)	Uniform Delay (pcuHr)	Rand + Oversat Delay (pcuHr)	Total Delay (pcuHr)	Av. Delay Per PCU (s/pcu)	Max. Back of Uniform Queue (pcu)	Rand + Oversat Queue (pcu)	Mean Max Queue (pcu)
Network: J23 M20 Junction 9	-	0	40.8	28.9	69.7	-	-	-	-
J1: M20 E/B Off Slip / M20 Junction 9 (13-1131)	-	0	10.4	5.8	16.2	-	-	-	-
1/2+1/1	171	-	0.9	0.1	1.0	21.6	1.4	0.1	1.5
1/3+1/4	793	-	5.1	3.0	8.1	36.7	7.3	3.0	10.4
2/1	643	-	1.8	1.0	2.8	15.6	8.0	1.0	9.0
2/2	624	-	1.7	0.9	2.6	15.2	7.6	0.9	8.5
2/3	387	-	0.9	0.3	1.2	11.4	4.0	0.3	4.3
3/1	715	-	0.0	0.3	0.3	1.3	0.0	0.3	0.3
3/2	441	-	0.0	0.1	0.1	1.0	0.0	0.1	0.1
J2: A251 Trinity Road / M20 Junction 9 (13-1132)	-	0	12.1	11.0	23.1	-	-	-	-
1/2+1/1	669	-	1.6	1.3	2.9	15.6	10.9	1.3	12.2
1/3	374	-	1.5	0.5	2.0	19.5	6.8	0.5	7.2
1/4	419	-	1.7	0.6	2.4	20.2	7.6	0.6	8.2
2/1	653	-	3.3	4.9	8.2	45.0	11.1	4.9	16.0
2/2+2/3	934	-	4.0	3.1	7.1	27.3	7.5	3.1	10.6
3/1	935	-	0.0	0.5	0.5	1.8	0.0	0.5	0.5
3/2	387	-	0.0	0.1	0.1	1.1	0.0	0.1	0.1
J3: M20 W/B Off Slip / M20 Junction 9 (13-1133)	-	0	10.9	9.4	20.3	-	-	-	-
1/1	882	-	3.0	5.4	8.5	34.6	13.2	5.4	18.7
1/2	694	-	2.0	1.3	3.3	17.1	8.5	1.3	9.8
1/3	151	-	0.3	0.1	0.4	9.0	1.2	0.1	1.3
2/2+2/1	554	-	3.0	0.8	3.8	24.8	4.4	0.8	5.2
2/3+2/4	492	-	2.6	0.6	3.2	23.5	3.6	0.6	4.2
3/1	1136	-	0.0	0.7	0.7	2.2	0.0	0.7	0.7
3/2	994	-	0.0	0.5	0.5	1.7	0.0	0.5	0.5

Full Input Data And Results

J4: A20 Fougères Way / M20 Junction 9 (13-1134)	-	0	7.4	2.7	10.1	-	-	-	-																																			
1/2+1/1	909	-	3.0	0.8	3.8	15.0	6.3	0.8	7.1																																			
1/3	373	-	1.1	0.4	1.6	15.3	4.1	0.4	4.6																																			
1/4	387	-	1.2	0.5	1.7	15.6	4.4	0.5	4.9																																			
2/1	151	-	0.4	0.1	0.5	12.4	0.8	0.1	0.9																																			
2/2	241	-	0.8	0.3	1.1	16.8	3.9	0.3	4.2																																			
2/3	251	-	0.9	0.3	1.2	16.9	4.1	0.3	4.4																																			
3/1	652	-	0.0	0.3	0.3	1.4	0.0	0.3	0.3																																			
3/2	6	-	0.0	0.0	0.0	0.9	0.0	0.0	0.0																																			
<table border="0"> <tr> <td>C1 - 13/1131</td> <td>PRC for Signalled Lanes (%):</td> <td>-1.5</td> <td>Total Delay for Signalled Lanes (pcuHr):</td> <td>15.76</td> <td>Cycle Time (s):</td> <td>65</td> </tr> <tr> <td>C2 - 13/1132</td> <td>PRC for Signalled Lanes (%):</td> <td>-2.2</td> <td>Total Delay for Signalled Lanes (pcuHr):</td> <td>22.50</td> <td>Cycle Time (s):</td> <td>65</td> </tr> <tr> <td>C3 - 13/1133</td> <td>PRC for Signalled Lanes (%):</td> <td>-2.9</td> <td>Total Delay for Signalled Lanes (pcuHr):</td> <td>19.17</td> <td>Cycle Time (s):</td> <td>59</td> </tr> <tr> <td>C4 - 13/1134</td> <td>PRC for Signalled Lanes (%):</td> <td>42.5</td> <td>Total Delay for Signalled Lanes (pcuHr):</td> <td>9.89</td> <td>Cycle Time (s):</td> <td>59</td> </tr> <tr> <td></td> <td>PRC Over All Lanes (%):</td> <td>-2.9</td> <td>Total Delay Over All Lanes(pcuHr):</td> <td>69.72</td> <td></td> <td></td> </tr> </table>										C1 - 13/1131	PRC for Signalled Lanes (%):	-1.5	Total Delay for Signalled Lanes (pcuHr):	15.76	Cycle Time (s):	65	C2 - 13/1132	PRC for Signalled Lanes (%):	-2.2	Total Delay for Signalled Lanes (pcuHr):	22.50	Cycle Time (s):	65	C3 - 13/1133	PRC for Signalled Lanes (%):	-2.9	Total Delay for Signalled Lanes (pcuHr):	19.17	Cycle Time (s):	59	C4 - 13/1134	PRC for Signalled Lanes (%):	42.5	Total Delay for Signalled Lanes (pcuHr):	9.89	Cycle Time (s):	59		PRC Over All Lanes (%):	-2.9	Total Delay Over All Lanes(pcuHr):	69.72		
C1 - 13/1131	PRC for Signalled Lanes (%):	-1.5	Total Delay for Signalled Lanes (pcuHr):	15.76	Cycle Time (s):	65																																						
C2 - 13/1132	PRC for Signalled Lanes (%):	-2.2	Total Delay for Signalled Lanes (pcuHr):	22.50	Cycle Time (s):	65																																						
C3 - 13/1133	PRC for Signalled Lanes (%):	-2.9	Total Delay for Signalled Lanes (pcuHr):	19.17	Cycle Time (s):	59																																						
C4 - 13/1134	PRC for Signalled Lanes (%):	42.5	Total Delay for Signalled Lanes (pcuHr):	9.89	Cycle Time (s):	59																																						
	PRC Over All Lanes (%):	-2.9	Total Delay Over All Lanes(pcuHr):	69.72																																								

F.27 J24_B2064 Cheriton High St Risborough Ln

Full Input Data And Results
Full Input Data And Results

User and Project Details

Project:	Otterpool Park
Title:	J24 Cheriton High Street/Risborough Lane
Location:	
Additional detail:	
File name:	J24_Cheriton High Str-Risborough Ln_Base Model.lsg3x
Author:	Diego Moreno-Sosa
Company:	ARCADIS UK
Address:	

Network Layout Diagram

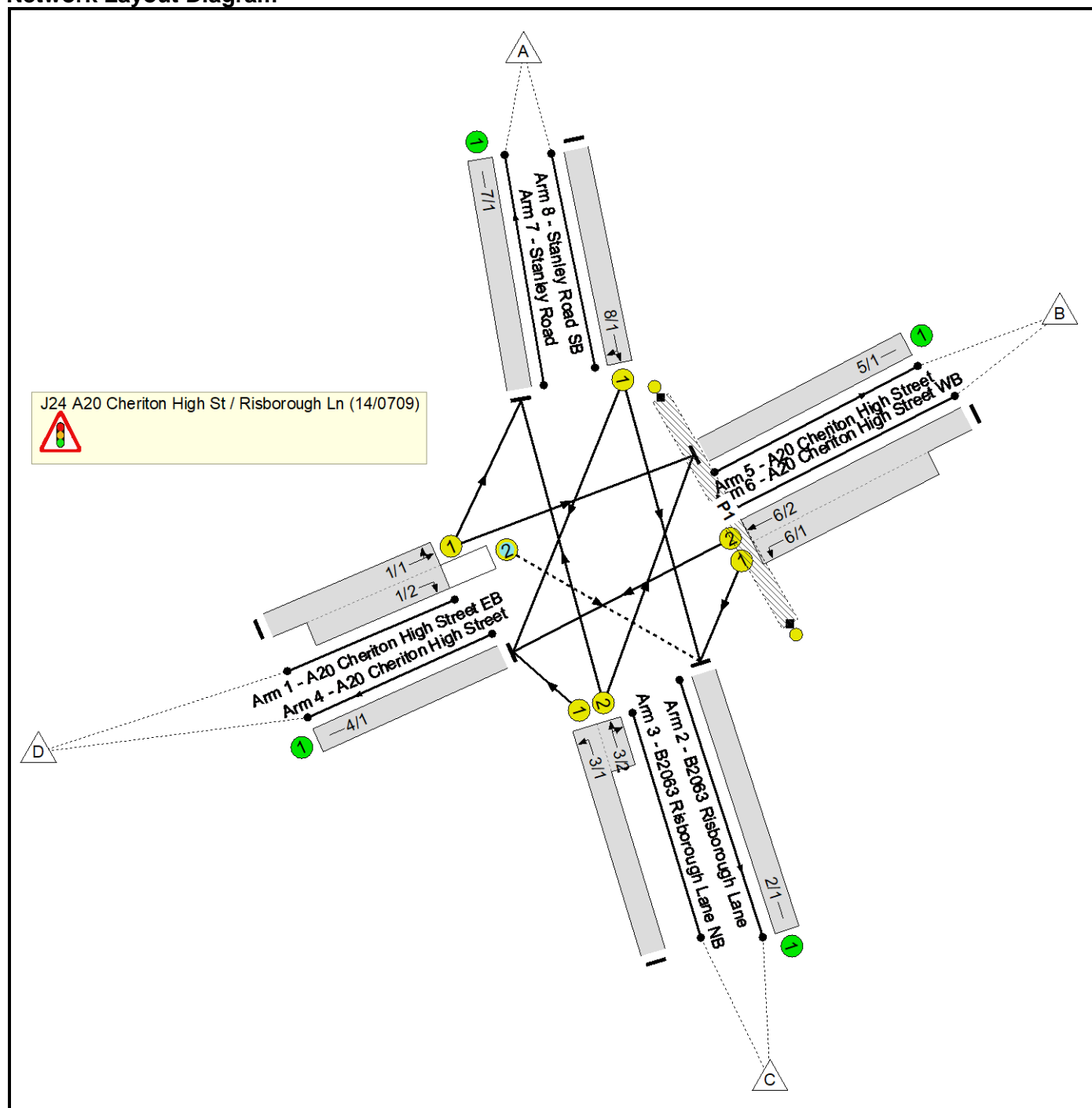

Full Input Data And Results

Phase Input Data

Phase Name	Phase Type	Assoc. Phase	Street Min	Cont Min
A	Traffic		7	7
B	Traffic		7	7
C	Traffic		7	7
D	Traffic		7	7
E	Pedestrian		6	6

Phase Intergreens Matrix

		Starting Phase				
		A	B	C	D	E
Terminating Phase	A	-	5	7	9	
	B	8	-	5	5	
	C	5	5	-	7	8
	D	7	5	8	-	
	E	11	11	11	-	

Phases in Stage

Stage No.	Phases in Stage
1	A B
2	C
3	D E

Stage Diagram

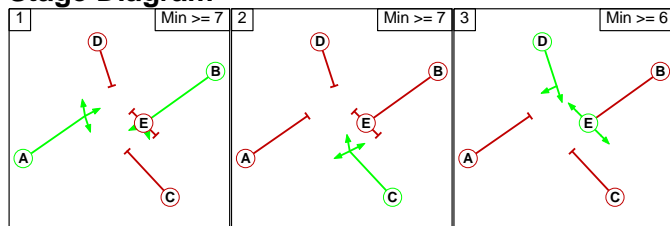

Phase Delays

Term. Stage	Start Stage	Phase	Type	Value	Cont value
There are no Phase Delays defined					

Full Input Data And Results

Traffic Flows, Desired

Scenario 1: 'Base AM' (FG1: 'AM PEAK', Plan 1: 'Network Control Plan 1')

Desired Flow :

		Destination				
		A	B	C	D	Tot.
Origin	A	0	0	93	44	137
	B	0	0	210	282	492
	C	49	258	0	276	583
	D	14	299	182	0	495
	Tot.	63	557	485	602	1707

Scenario 2: 'Base PM' (FG2: 'PM PEAK', Plan 1: 'Network Control Plan 1')

Desired Flow :

		Destination				
		A	B	C	D	Tot.
Origin	A	0	0	57	28	85
	B	0	0	217	316	533
	C	28	243	0	319	590
	D	20	443	220	0	683
	Tot.	48	686	494	663	1891

Scenario 1: 'Base AM' (FG1: 'AM PEAK', Plan 1: 'Network Control Plan 1')

Stage Sequence Diagram

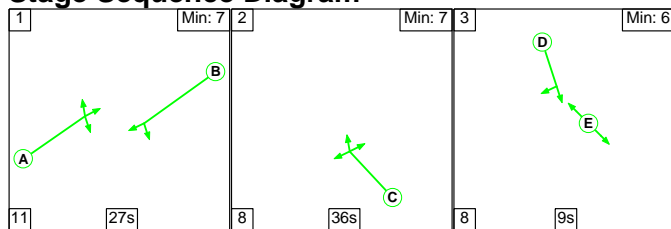

Stage Timings

Stage	1	2	3
Duration	27	36	9
Change Point	0	38	82

Signal Timings Diagram

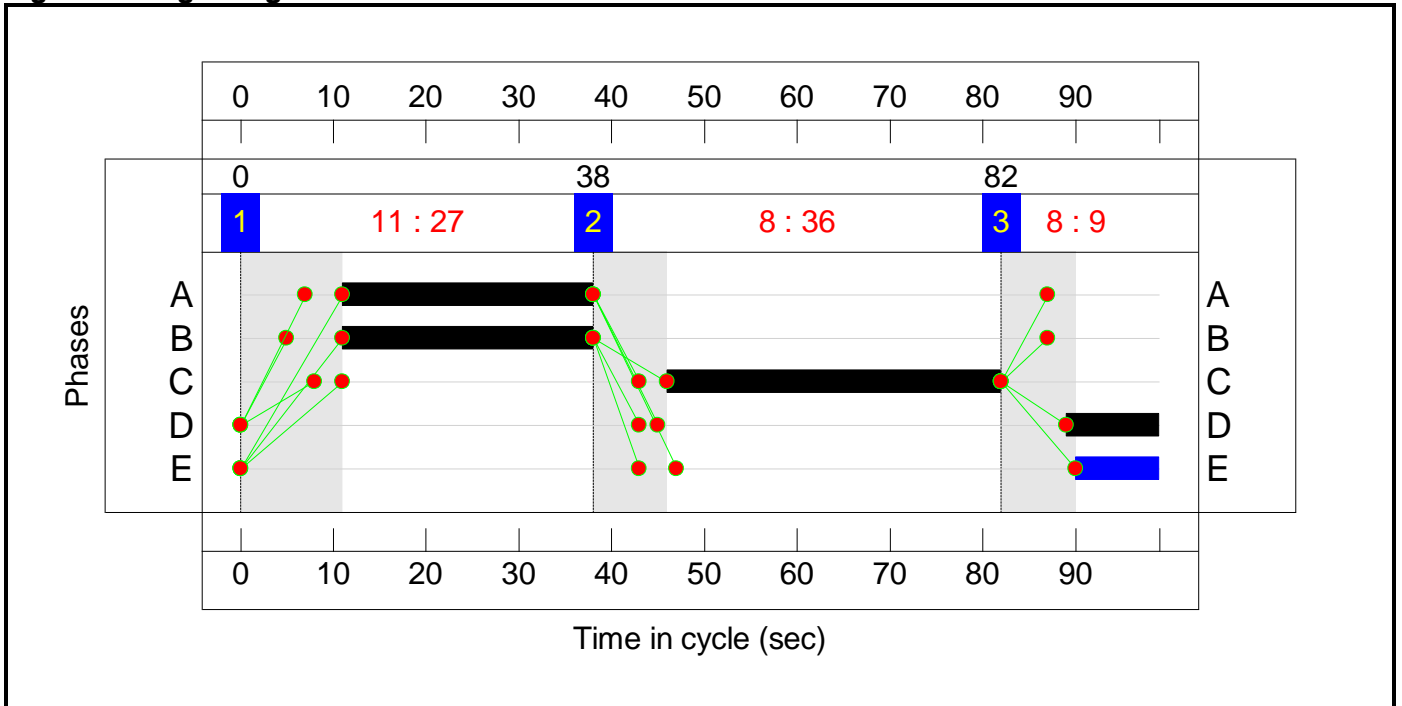

Full Input Data And Results
Network Layout Diagram

J24 A20 Cheriton High St / Risborough Ln (14/0709)
 PRC: 8.1 %
 Total Traffic Delay: 20.1 pcuHr
 Ave. Route Delay Per Ped: 0.0 s/Ped

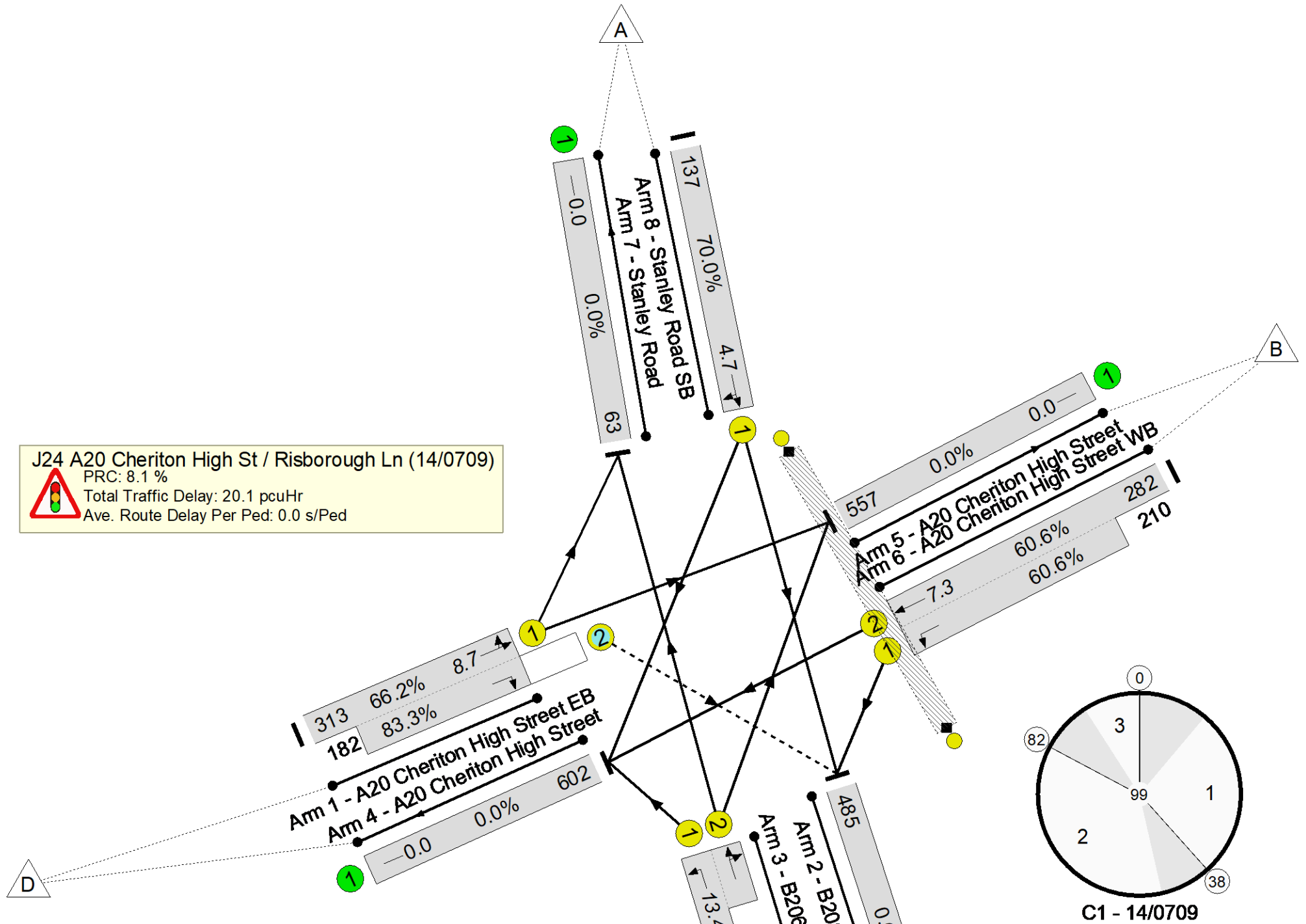

Full Input Data And Results

Network Results

Scenario 1: 'Base AM' (FG1: 'AM PEAK', Plan 1: 'Network Control Plan 1')

Item	Lane Description	Lane Type	Total Green (s)	Arrow Green (s)	Demand Flow (pcu)	Sat Flow (pcu/Hr)	Capacity (pcu)	Deg Sat (%)	Arriving (pcu)
Network: J24 Cheriton High Street/Risborough Lane	-	-	-	-	-	-	-	83.3%	-
J24 A20 Cheriton High St / Risborough Ln (14/0709)	-	-	-	-	-	-	-	83.3%	-
1/1+1/2	A20 Cheriton High Street EB Right Ahead Left	U+O	27	-	495	1758:1654	473+219	66.2 : 83.3%	495
2/1	B2063 Risborough Lane	U	-	-	485	Inf	Inf	0.0%	485
3/1+3/2	B2063 Risborough Lane NB Left Right Ahead	U	36	-	583	1555:1674	338+375	81.8 : 81.8%	583
4/1	A20 Cheriton High Street	U	-	-	602	Inf	Inf	0.0%	602
5/1	A20 Cheriton High Street	U	-	-	557	Inf	Inf	0.0%	557
6/2+6/1	A20 Cheriton High Street WB Left Ahead	U	27	-	492	1733:1600	465+347	60.6 : 60.6%	492
7/1	Stanley Road	U	-	-	63	Inf	Inf	0.0%	63
8/1	Stanley Road SB Ahead Right	U	10	-	137	1761	196	70.0%	137
Ped Link: P1	Unnamed Ped Link	-	0	-	0	-	0	0.0%	0

Full Input Data And Results

Scenario 2: 'Base PM' (FG2: 'PM PEAK', Plan 1: 'Network Control Plan 1')

Item	Lane Description	Lane Type	Total Green (s)	Arrow Green (s)	Demand Flow (pcu)	Sat Flow (pcu/Hr)	Capacity (pcu)	Deg Sat (%)	Arriving (pcu)
Network: J24 Cheriton High Street/Risborough Lane	-	-	-	-	-	-	-	87.2%	-
J24 A20 Cheriton High St / Risborough Ln (14/0709)	-	-	-	-	-	-	-	87.2%	-
1/1+1/2	A20 Cheriton High Street EB Right Ahead Left	U+O	40	-	683	1758:1654	544+258	85.1 : 85.1%	683
2/1	B2063 Risborough Lane	U	-	-	494	Inf	Inf	0.0%	494
3/1+3/2	B2063 Risborough Lane NB Left Right Ahead	U	42	-	590	1555:1674	366+311	87.2 : 87.2%	590
4/1	A20 Cheriton High Street	U	-	-	663	Inf	Inf	0.0%	663
5/1	A20 Cheriton High Street	U	-	-	686	Inf	Inf	0.0%	686
6/2+6/1	A20 Cheriton High Street WB Left Ahead	U	40	-	533	1733:1600	514+353	61.5 : 61.5%	533
7/1	Stanley Road	U	-	-	48	Inf	Inf	0.0%	48
8/1	Stanley Road SB Ahead Right	U	7	-	85	1761	123	69.4%	85
Ped Link: P1	Unnamed Ped Link	-	0	-	0	-	0	0.0%	0

Full Input Data And Results

Item	Leaving (pcu)	Turners In Intergreen (pcu)	Uniform Delay (pcuHr)	Rand + Oversat Delay (pcuHr)	Total Delay (pcuHr)	Av. Delay Per PCU (s/pcu)	Max. Back of Uniform Queue (pcu)	Rand + Oversat Queue (pcu)	Mean Max Queue (pcu)
Network: J24 Cheriton High Street/Risborough Lane	-	40	16.8	7.8	25.3	-	-	-	-
J24 A20 Cheriton High St / Risborough Ln (14/0709)	-	40	16.8	7.8	25.3	-	-	-	-
1/1+1/2	683	40	6.2	2.7	9.8	51.4	14.1	2.7	16.8
2/1	494	-	0.0	0.0	0.0	0.0	0.0	0.0	0.0
3/1+3/2	590	-	5.1	3.2	8.2	50.3	14.7	3.2	17.8
4/1	663	-	0.0	0.0	0.0	0.0	0.0	0.0	0.0
5/1	686	-	0.0	0.0	0.0	0.0	0.0	0.0	0.0
6/2+6/1	533	-	4.2	0.8	5.0	33.8	7.9	0.8	8.7
7/1	48	-	0.0	0.0	0.0	0.0	0.0	0.0	0.0
8/1	85	-	1.2	1.1	2.3	97.7	2.6	1.1	3.7
Ped Link: P1	0	-	-	-	Inf	Inf	-	-	Inf
<p>C1 - 14/0709 PRC for Signalled Lanes (%): 3.3 Total Delay for Signalled Lanes (pcuHr): 25.32 Cycle Time (s): 115 PRC Over All Lanes (%): 3.3 Total Delay Over All Lanes(pcuHr): 25.32</p>									

F.28 J25 B2064 Cheriton High Street-A2034 Cherry Garden Avenue

Full Input Data And Results
Full Input Data And Results

User and Project Details

Project:	Otterpool Park
Title:	J25 B2064 Cheriton High Street/A2034 Cherry Garden Ave
Location:	
Additional detail:	
File name:	J25_B2064 Cheriton High street-A2034 Cherry Garden Avenue_Base Model.lsg3x
Author:	Diego Moreno-Sosa
Company:	ARCADIS UK
Address:	

Network Layout Diagram

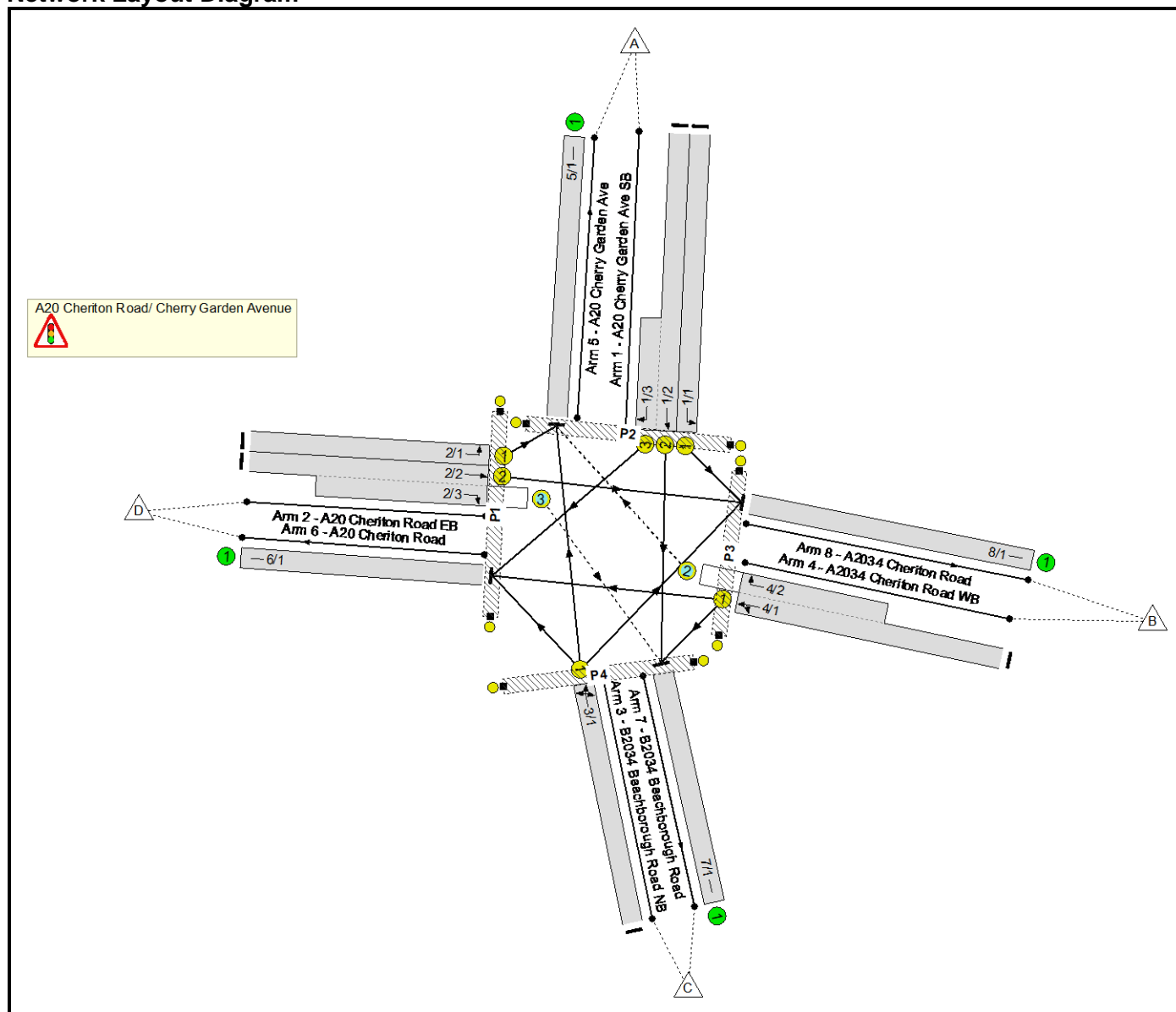

Full Input Data And Results

Phase Input Data

Phase Name	Phase Type	Assoc. Phase	Street Min	Cont Min
A	Traffic		7	7
B	Traffic		7	7
C	Traffic		7	7
D	Traffic		7	7
E	Traffic		3	3
F	Pedestrian		6	6
G	Pedestrian		6	6
H	Pedestrian		7	7
I	Pedestrian		6	6
J	Pedestrian		7	7

Phase Intergreens Matrix

Terminating Phase	Starting Phase										
	A	B	C	D	E	F	G	H	I	J	
A	-	10	-	7	-	9	-	9	9	9	
B	6	-	6	9	-	-	6	10	10	10	
C	-	10	-	7	-	9	-	9	9	9	
D	6	10	6	-	6	9	-	9	9	9	
E	-	-	-	7	-	9	-	9	9	9	
F	9	-	9	9	9	-	-	-	-	-	
G	-	10	-	-	-	-	-	-	-	-	
H	14	14	14	14	14	-	-	-	-	-	
I	14	14	14	14	14	-	-	-	-	-	
J	14	14	14	14	14	-	-	-	-	-	

Phases in Stage

Stage No.	Phases in Stage
1	A C E G
2	F G H I J
3	D G
4	B F
5	B E

Stage Diagram

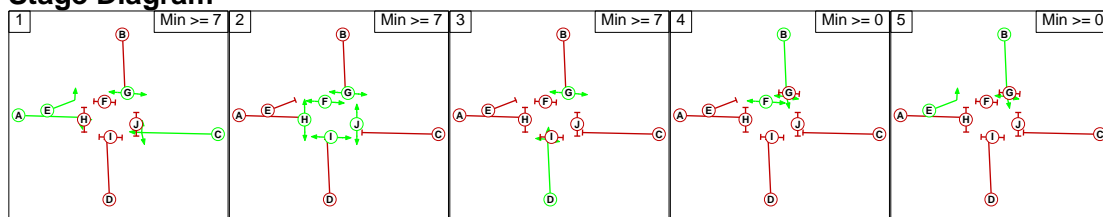

Full Input Data And Results

Phase Delays

Term. Stage	Start Stage	Phase	Type	Value	Cont value
There are no Phase Delays defined					

Traffic Flows, Desired

Scenario 1: 'Base AM' (FG1: 'AM PEAK', Plan 1: 'Network Control Plan 1')

Desired Flow :

Origin	Destination					Tot.
	A	B	C	D		
A	0	303	347	66	716	
B	101	0	62	248	411	
C	317	61	0	34	412	
D	172	337	73	0	582	
Tot.	590	701	482	348	2121	

Scenario 2: 'Base PM' (FG2: 'PM PEAK', Plan 1: 'Network Control Plan 1')

Desired Flow :

Origin	Destination					Tot.
	A	B	C	D		
A	0	252	276	81	609	
B	93	0	50	228	371	
C	395	62	0	46	503	
D	171	371	80	0	622	
Tot.	659	685	406	355	2105	

Scenario 1: 'Base AM' (FG1: 'AM PEAK', Plan 1: 'Network Control Plan 1')

Stage Sequence Diagram

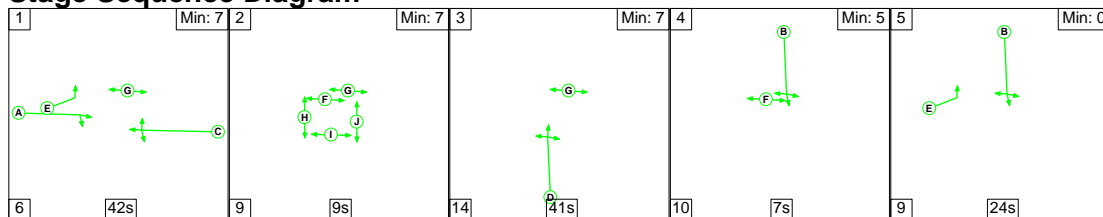

Stage Timings

Stage	1	2	3	4	5
Duration	42	9	41	7	24
Change Point	0	48	66	121	138

Full Input Data And Results

Signal Timings Diagram

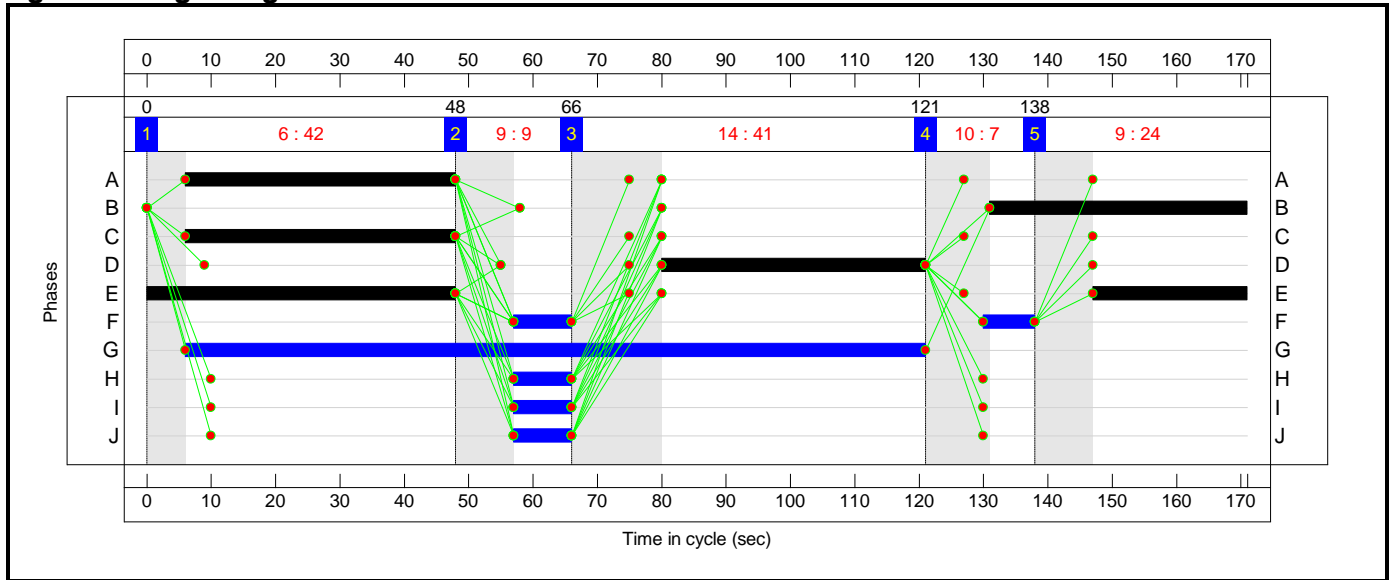

Full Input Data And Results
Network Layout Diagram

Full Input Data And Results

A20 Cheriton Road/ Cherry Garden Avenue
 PRC: -1.1 %
 Total Traffic Delay: 47.0 pcuHr
 Ave. Route Delay Per Ped: 0.0 s/Ped

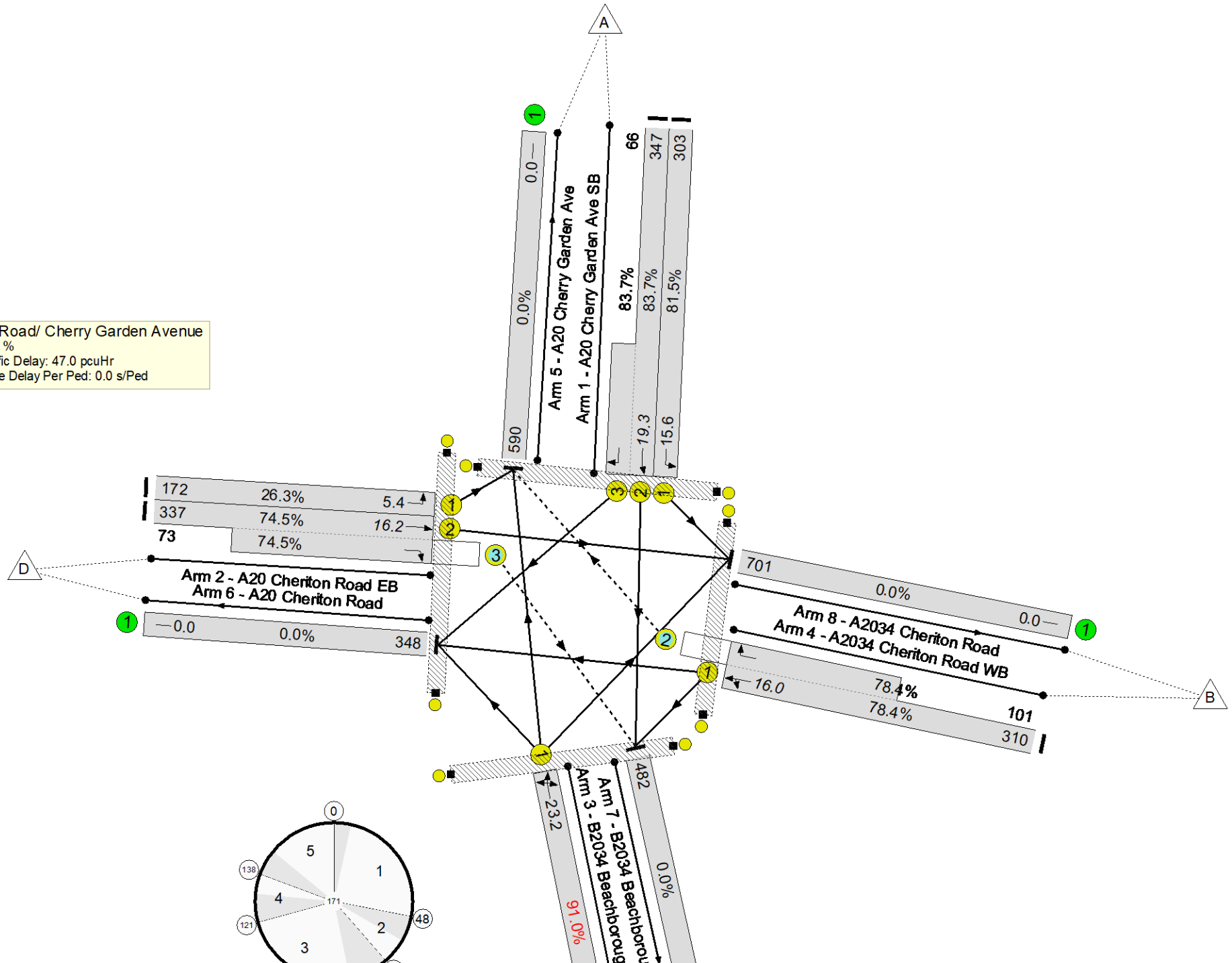

Full Input Data And Results

Network Results

Scenario 1: 'Base AM' (FG1: 'AM PEAK', Plan 1: 'Network Control Plan 1')

Item	Lane Description	Lane Type	Total Green (s)	Arrow Green (s)	Demand Flow (pcu)	Sat Flow (pcu/Hr)	Capacity (pcu)	Deg Sat (%)	Arriving (pcu)
Network: J25 B2064 Cheriton High Street/A2034 Cherry Garden Ave	-	-	-	-	-	-	-	91.0%	-
A20 Cheriton Road/ Cherry Garden Avenue	-	-	-	-	-	-	-	91.0%	-
1/1	A20 Cherry Garden Ave SB Left	U	40	-	303	1550	372	81.5%	303
1/2+1/3	A20 Cherry Garden Ave SB Right Ahead	U	40	-	413	1929:1750	415+79	83.7 : 83.7%	413
2/1	A20 Cheriton Road EB Left	U	72	-	172	1534	655	26.3%	172
2/2+2/3	A20 Cheriton Road EB Right Ahead	U+O	42	-	410	1929:1746	453+98	74.5 : 74.5%	410
3/1	B2034 Beachborough Road NB Ahead Left Right	U	41	-	412	1844	453	91.0%	412
4/1+4/2	A2034 Cheriton Road WB Right Ahead Left	U+O	42	-	411	1779:1729	395+129	78.4 : 78.4%	411
5/1	A20 Cherry Garden Ave	U	-	-	590	Inf	Inf	0.0%	590
6/1	A20 Cheriton Road	U	-	-	348	Inf	Inf	0.0%	348
7/1	B2034 Beachborough Road	U	-	-	482	Inf	Inf	0.0%	482
8/1	A2034 Cheriton Road	U	-	-	701	Inf	Inf	0.0%	701
Ped Link: P1	Unnamed Ped Link	-	0	-	0	-	0	0.0%	0
Ped Link: P2	Unnamed Ped Link	-	0	-	0	-	0	0.0%	0
Ped Link: P3	Unnamed Ped Link	-	0	-	0	-	0	0.0%	0
Ped Link: P4	Unnamed Ped Link	-	0	-	0	-	0	0.0%	0

Full Input Data And Results

Scenario 2: 'Base PM' (FG2: 'PM PEAK', Plan 1: 'Network Control Plan 1')

Item	Lane Description	Lane Type	Total Green (s)	Arrow Green (s)	Demand Flow (pcu)	Sat Flow (pcu/Hr)	Capacity (pcu)	Deg Sat (%)	Arriving (pcu)
Network: J25 B2064 Cheriton High Street/A2034 Cherry Garden Ave	-	-	-	-	-	-	-	94.1%	-
A20 Cheriton Road/ Cherry Garden Avenue	-	-	-	-	-	-	-	94.1%	-
1/1	A20 Cherry Garden Ave SB Left	U	28	-	252	1550	290	86.9%	252
1/2+1/3	A20 Cherry Garden Ave SB Right Ahead	U	28	-	357	1929:1750	322+95	85.7 : 85.7%	357
2/1	A20 Cheriton Road EB Left	U	55	-	171	1534	554	30.9%	171
2/2+2/3	A20 Cheriton Road EB Right Ahead	U+O	35	-	451	1929:1746	429+93	86.5 : 86.5%	451
3/1	B2034 Beachborough Road NB Ahead Left Right	U	44	-	503	1844	535	94.0%	503
4/1+4/2	A2034 Cheriton Road WB Right Ahead Left	U+O	35	-	371	1779:1729	375+99	74.1 : 94.1%	371
5/1	A20 Cherry Garden Ave	U	-	-	659	Inf	Inf	0.0%	659
6/1	A20 Cheriton Road	U	-	-	355	Inf	Inf	0.0%	355
7/1	B2034 Beachborough Road	U	-	-	406	Inf	Inf	0.0%	406
8/1	A2034 Cheriton Road	U	-	-	685	Inf	Inf	0.0%	685
Ped Link: P1	Unnamed Ped Link	-	0	-	0	-	0	0.0%	0
Ped Link: P2	Unnamed Ped Link	-	0	-	0	-	0	0.0%	0
Ped Link: P3	Unnamed Ped Link	-	0	-	0	-	0	0.0%	0
Ped Link: P4	Unnamed Ped Link	-	0	-	0	-	0	0.0%	0

F.29 J26_Prospect Rd Stade St

Full Input Data And Results
Full Input Data And Results

User and Project Details

Project:	
Title:	
Location:	
Additional detail:	
File name:	J26_Prospect Rd Stade St.lsg3x
Author:	
Company:	
Address:	

Network Layout Diagram

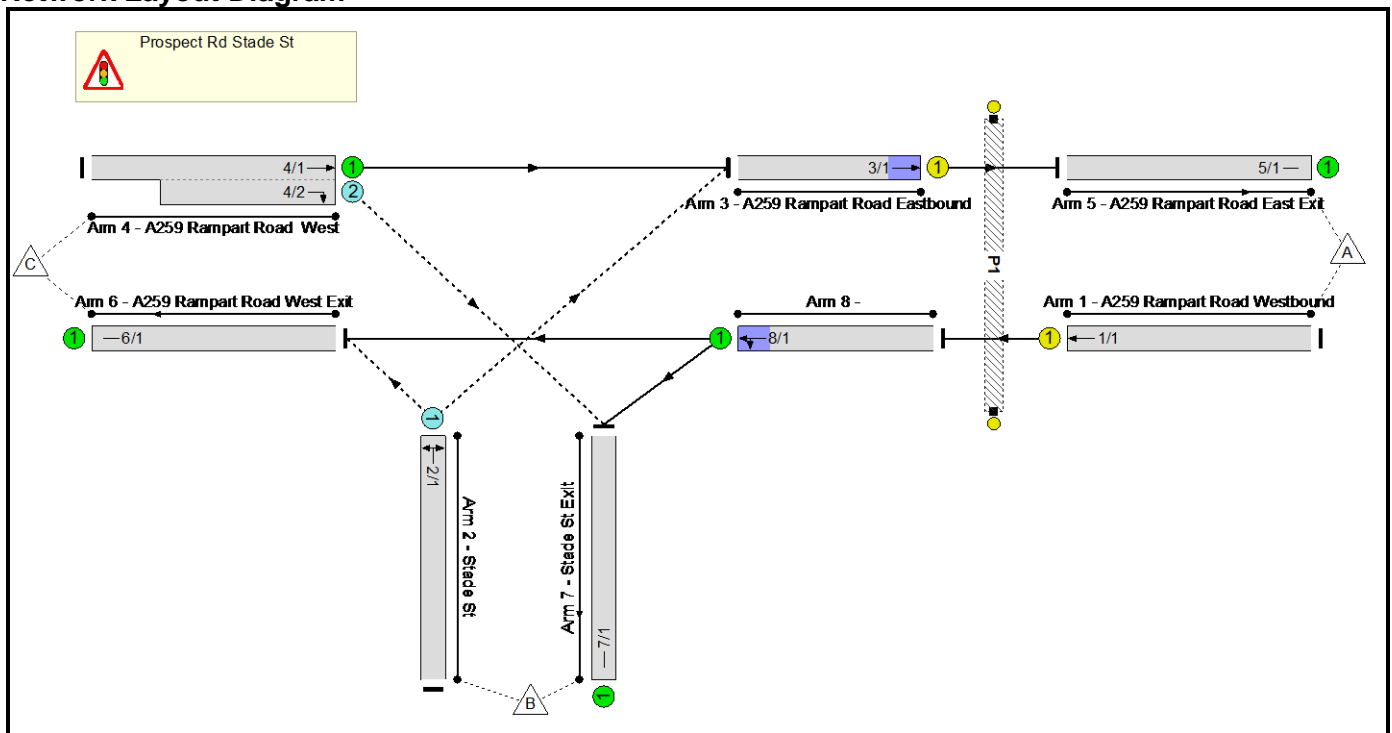

Phase Input Data

Phase Name	Phase Type	Assoc. Phase	Street Min	Cont Min
A	Traffic		-9999	7
B	Traffic		-9999	7
C	Pedestrian		-9999	6

Full Input Data And Results

Phase Intergreens Matrix

Terminating Phase	Starting Phase			
		A	B	C
	A		-	5
	B	-		5
C	10	10		

Phases in Stage

Stage No.	Phases in Stage
1	A B
2	C

Stage Diagram

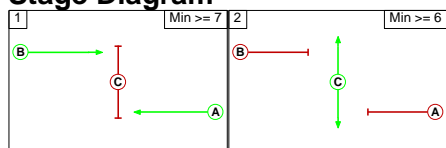

Phase Delays

Term. Stage	Start Stage	Phase	Type	Value	Cont value
There are no Phase Delays defined					

Traffic Flows, Desired

Scenario 1: 'Base AM' (FG5: 'Base AM', Plan 1: 'Network Control Plan 1')

Desired Flow :

Origin	Destination				Tot.
	A	B	C	Tot.	
A	0	137	385	522	
B	88	0	49	137	
C	738	153	0	891	
Tot.	826	290	434	1550	

Scenario 2: 'Base PM' (FG6: 'Base PM', Plan 1: 'Network Control Plan 1')

Desired Flow :

Origin	Destination				Tot.
	A	B	C	Tot.	
A	0	138	562	700	
B	79	0	48	127	
C	695	241	0	936	
Tot.	774	379	610	1763	

Scenario 1: 'Base AM' (FG5: 'Base AM', Plan 1: 'Network Control Plan 1')

Stage Sequence Diagram

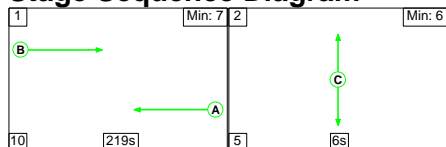

Full Input Data And Results

Stage Timings

Stage	1	2
Duration	219	6
Change Point	0	229

Signal Timings Diagram

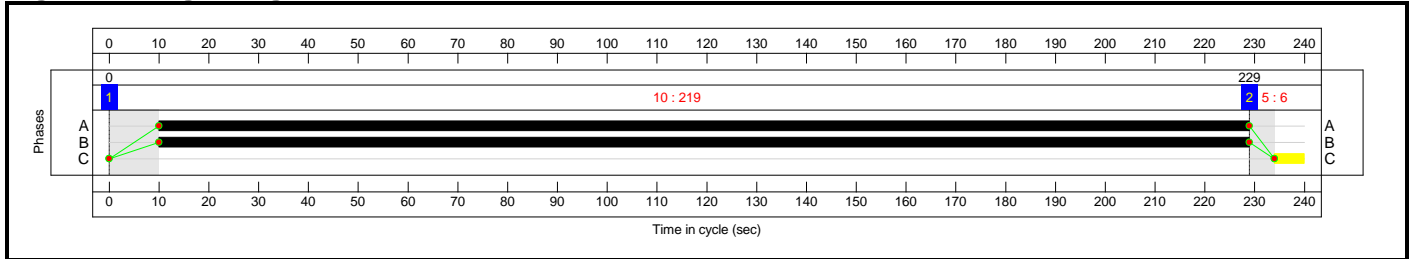

Full Input Data And Results
Network Layout Diagram

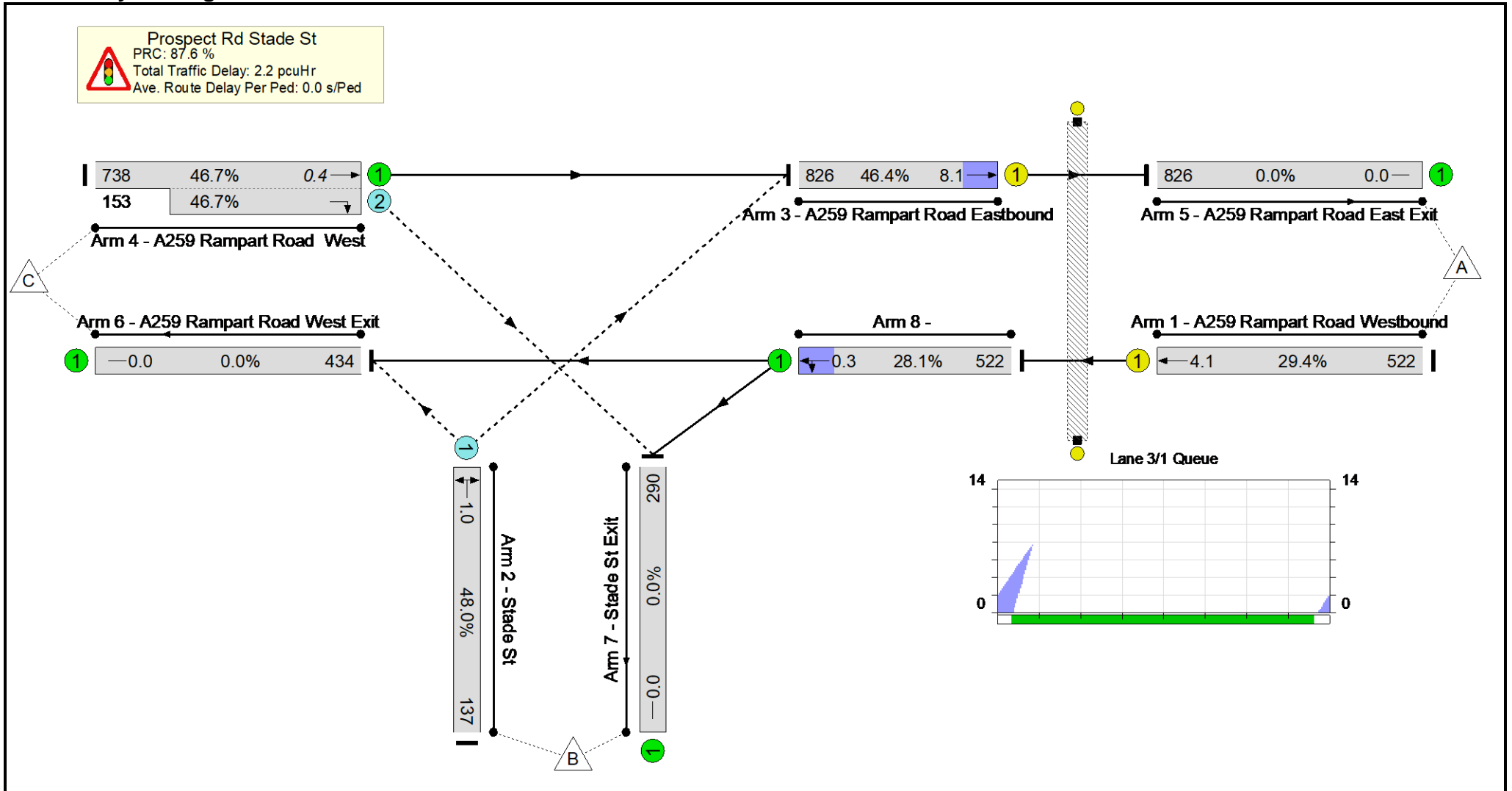

Full Input Data And Results

Network Results

Scenario 1: 'Base AM' (FG5: 'Base AM', Plan 1: 'Network Control Plan 1')

Item	Lane Description	Lane Type	Total Green (s)	Arrow Green (s)	Demand Flow (pcu)	Sat Flow (pcu/Hr)	Capacity (pcu)	Deg Sat (%)	Arriving (pcu)
Network	-	-	-	-	-	-	-	48.0%	-
Prospect Rd Stade St	-	-	-	-	-	-	-	48.0%	-
1/1	A259 Rampart Road Westbound Ahead	U	219	-	522	1940	1778	29.4%	522
2/1	Stade St Right Left	O	-	-	137	1719	286	48.0%	137
3/1	A259 Rampart Road Eastbound Ahead	U	219	-	826	1940	1778	46.4%	826
4/1+4/2	A259 Rampart Road West Ahead Right	U+O	-	-	891	1940:1764	1580+328	46.7 : 46.7%	891
5/1	A259 Rampart Road East Exit	U	-	-	826	Inf	Inf	0.0%	826
6/1	A259 Rampart Road West Exit	U	-	-	434	Inf	Inf	0.0%	434
7/1	Stade St Exit	U	-	-	290	Inf	Inf	0.0%	290
8/1	Ahead Left	U	-	-	522	1859	1859	28.1%	522
Ped Link: P1	Unnamed Ped Link	-	6	-	0	-	0	0.0%	0

Full Input Data And Results

Item	Leaving (pcu)	Turners In Intergreen (pcu)	Uniform Delay (pcuHr)	Rand + Oversat Delay (pcuHr)	Total Delay (pcuHr)	Av. Delay Per PCU (s/pcu)	Max. Back of Uniform Queue (pcu)	Rand + Oversat Queue (pcu)	Mean Max Queue (pcu)
Network	-	0	0.5	1.7	2.2	-	-	-	-
Prospect Rd Stade St	-	0	0.5	1.7	2.2	-	-	-	-
1/1	522	-	0.2	0.2	0.4	2.6	3.9	0.2	4.1
2/1	137	0	0.0	0.5	0.5	12.3	0.6	0.5	1.0
3/1	826	-	0.3	0.4	0.8	3.3	7.7	0.4	8.1
4/1+4/2	891	0	0.0	0.4	0.4	1.8	0.0	0.4	0.4
5/1	826	-	0.0	0.0	0.0	0.0	0.0	0.0	0.0
6/1	434	-	0.0	0.0	0.0	0.0	0.0	0.0	0.0
7/1	290	-	0.0	0.0	0.0	0.0	0.0	0.0	0.0
8/1	522	-	0.0	0.2	0.2	1.3	0.1	0.2	0.3
Ped Link: P1	0	-	-	-	-	-	-	-	-

C1

PRC for Signalled Lanes (%): 93.8
 PRC Over All Lanes (%): 87.6

Total Delay for Signalled Lanes (pcuHr): 1.14
 Total Delay Over All Lanes(pcuHr): 2.24

Cycle Time (s): 240

Full Input Data And Results

Scenario 2: 'Base PM' (FG6: 'Base PM ', Plan 1: 'Network Control Plan 1')

Item	Lane Description	Lane Type	Total Green (s)	Arrow Green (s)	Demand Flow (pcu)	Sat Flow (pcu/Hr)	Capacity (pcu)	Deg Sat (%)	Arriving (pcu)
Network	-	-	-	-	-	-	-	57.9%	-
Prospect Rd Stade St	-	-	-	-	-	-	-	57.9%	-
1/1	A259 Rampart Road Westbound Ahead	U	219	-	700	1940	1778	39.4%	700
2/1	Stade St Right Left	O	-	-	127	1717	219	57.9%	127
3/1	A259 Rampart Road Eastbound Ahead	U	219	-	774	1940	1778	43.5%	774
4/1+4/2	A259 Rampart Road West Ahead Right	U+O	-	-	936	1940:1764	1404+478	49.5 : 50.5%	936
5/1	A259 Rampart Road East Exit	U	-	-	774	Inf	Inf	0.0%	774
6/1	A259 Rampart Road West Exit	U	-	-	610	Inf	Inf	0.0%	610
7/1	Stade St Exit	U	-	-	379	Inf	Inf	0.0%	379
8/1	Ahead Left	U	-	-	700	1878	1878	37.3%	700
Ped Link: P1	Unnamed Ped Link	-	6	-	0	-	0	0.0%	0

F.30 J27 Barrow_Hill_Funnel_Junction

Full Input Data And Results

User and Project Details

Project:	Otterpool Park
Title:	Barrow Hill Funnel Junction
Location:	
Additional detail:	
File name:	J27_Barrow Hill Ashford Road Funnel Junction_Base Model.lsg3x
Author:	Diego Moreno-Sosa
Company:	ARCADIS UK
Address:	

Full Input Data And Results

Network Layout Diagram

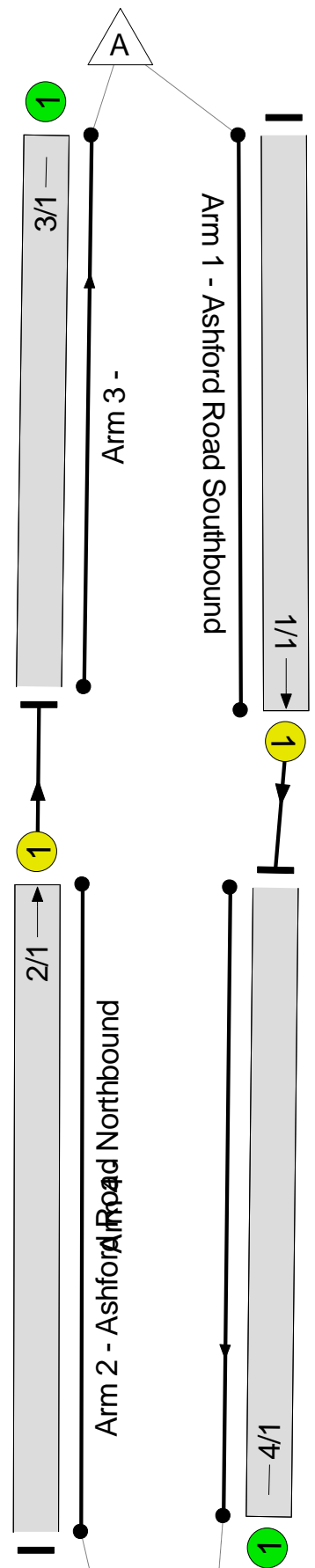
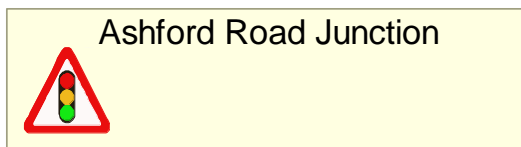

Full Input Data And Results

Phase Input Data

Phase Name	Phase Type	Assoc. Phase	Street Min	Cont Min
A	Traffic		7	7
B	Traffic		7	7

Phase Intergreens Matrix

	Starting Phase	
Terminating Phase	A	B
	A	11
	B	11

Phases in Stage

Stage No.	Phases in Stage
1	A
2	B

Stage Diagram

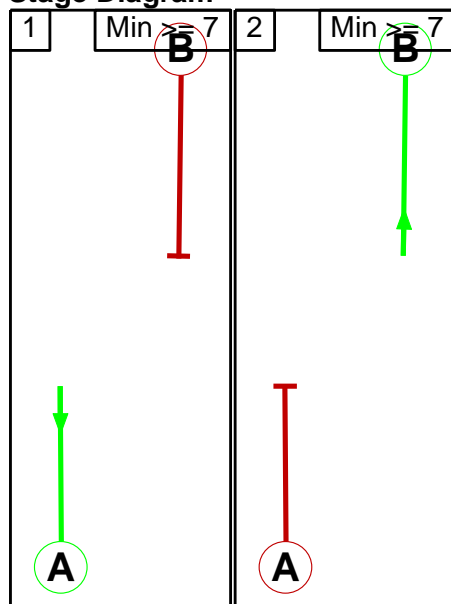

Phase Delays

Term. Stage	Start Stage	Phase	Type	Value	Cont value
There are no Phase Delays defined					

Traffic Flows, Desired

Scenario 1: 'Base AM' (FG1: 'AM Peak Period', Plan 1: 'Network Control Plan 1')

Desired Flow :

	Destination			
	A	B	Tot.	
Origin	A	0	268	268
	B	327	0	327
	Tot.	327	268	595

Full Input Data And Results

Scenario 2: 'Base PM' (FG2: 'PM Peak Period', Plan 1: 'Network Control Plan 1')

Desired Flow :

		Destination		
		A	B	Tot.
Origin	A	0	284	284
	B	275	0	275
	Tot.	275	284	559

Scenario 1: 'Base AM' (FG1: 'AM Peak Period', Plan 1: 'Network Control Plan 1')

Stage Sequence Diagram

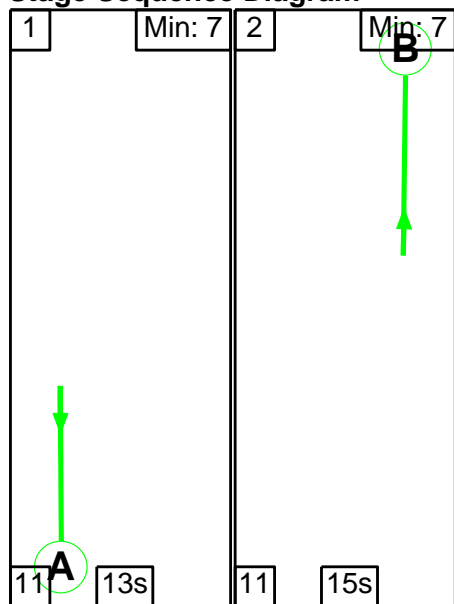

Stage Timings

Stage	1	2
Duration	13	15
Change Point	0	24

Signal Timings Diagram

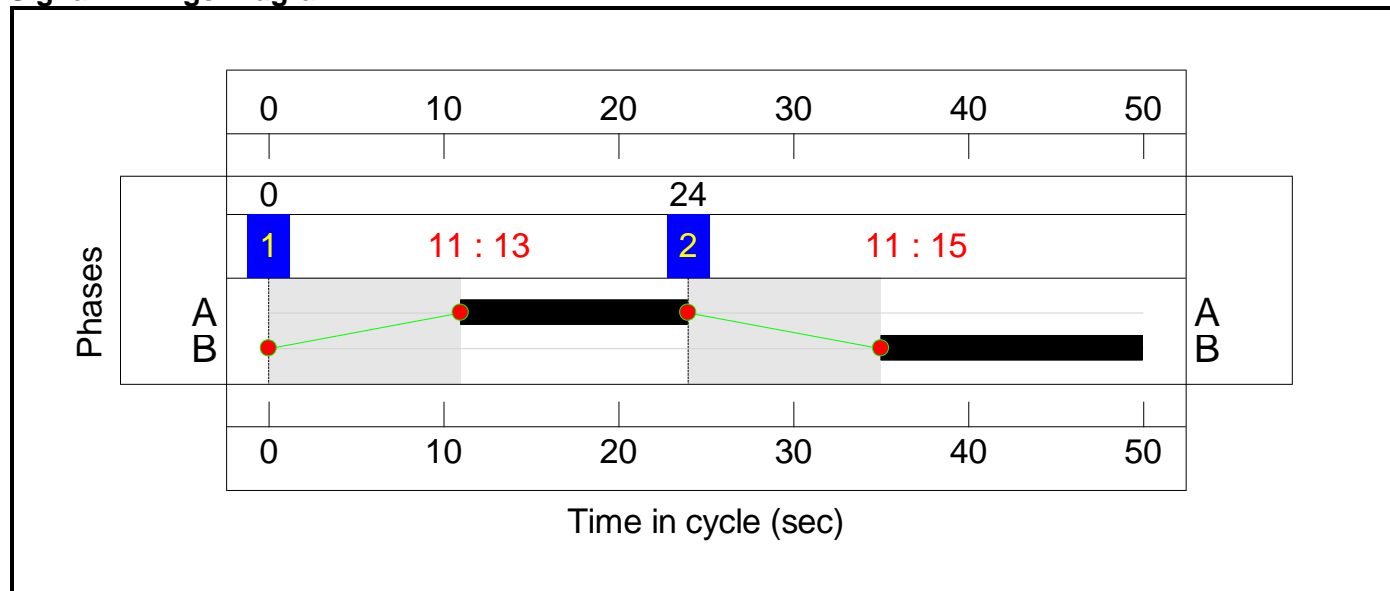

Full Input Data And Results
Network Layout Diagram

 **Ashford Road Junction**
PRC: 68.7 %
Total Traffic Delay: 3.5 pcuHr

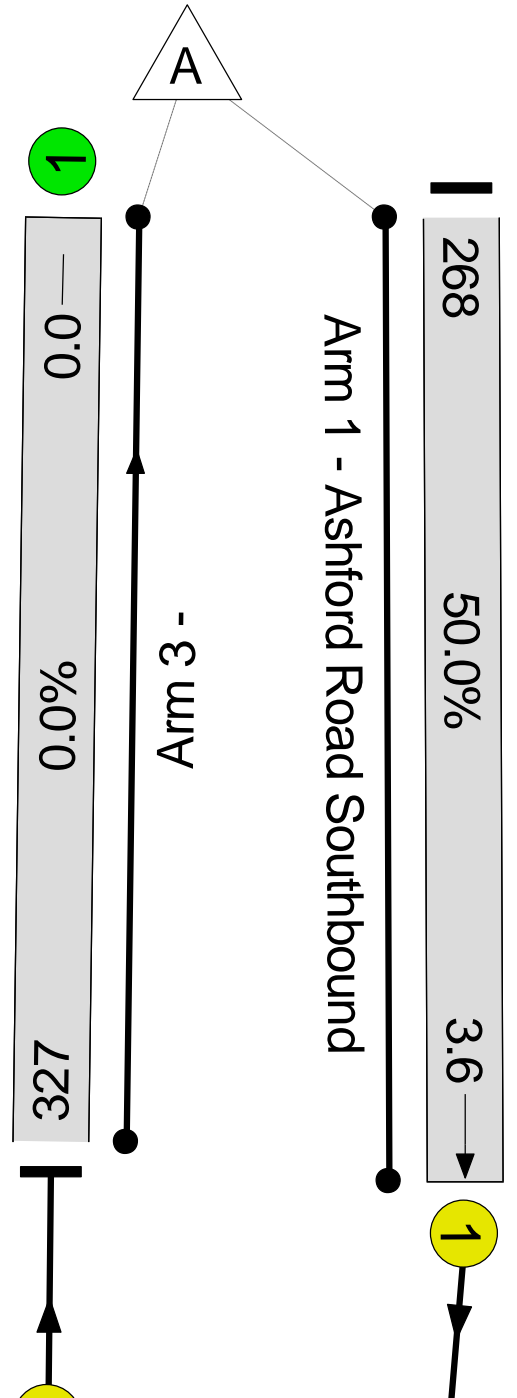

Full Input Data And Results

Network Results

Scenario 1: 'Base AM' (FG1: 'AM Peak Period', Plan 1: 'Network Control Plan 1')

Item	Lane Description	Lane Type	Total Green (s)	Arrow Green (s)	Demand Flow (pcu)	Sat Flow (pcu/Hr)	Capacity (pcu)	Deg Sat (%)	Arriving (pcu)
Network: Barrow Hill Funnel Junction	-	-	-	-	-	-	-	53.4%	-
Ashford Road Junction	-	-	-	-	-	-	-	53.4%	-
1/1	Ashford Road Southbound Ahead	U	13	-	268	1915	536	50.0%	268
2/1	Ashford Road Northbound Ahead	U	15	-	327	1915	613	53.4%	327
3/1		U	-	-	327	Inf	Inf	0.0%	327
4/1		U	-	-	268	Inf	Inf	0.0%	268
Item	Leaving (pcu)	Turners In Intergreen (pcu)	Uniform Delay (pcuHr)	Rand + Oversat Delay (pcuHr)	Total Delay (pcuHr)	Av. Delay Per PCU (s/pcu)	Max. Back of Uniform Queue (pcu)	Rand + Oversat Queue (pcu)	Mean Max Queue (pcu)
Network: Barrow Hill Funnel Junction	-	0	2.4	1.1	3.5	-	-	-	-
Ashford Road Junction	-	0	2.4	1.1	3.5	-	-	-	-
1/1	268	-	1.1	0.5	1.6	21.8	3.1	0.5	3.6
2/1	327	-	1.3	0.6	1.8	20.2	3.7	0.6	4.3
3/1	327	-	0.0	0.0	0.0	0.0	0.0	0.0	0.0
4/1	268	-	0.0	0.0	0.0	0.0	0.0	0.0	0.0
C1		PRC for Signalled Lanes (%):	68.7	Total Delay for Signalled Lanes (pcuHr):		3.46	Cycle Time (s): 50		
		PRC Over All Lanes (%):	68.7	Total Delay Over All Lanes(pcuHr):		3.46			

Full Input Data And Results

Scenario 2: 'Base PM' (FG2: 'PM Peak Period', Plan 1: 'Network Control Plan 1')

Item	Lane Description	Lane Type	Total Green (s)	Arrow Green (s)	Demand Flow (pcu)	Sat Flow (pcu/Hr)	Capacity (pcu)	Deg Sat (%)	Arriving (pcu)
Network: Barrow Hill Funnel Junction	-	-	-	-	-	-	-	49.4%	-
Ashford Road Junction	-	-	-	-	-	-	-	49.4%	-
1/1	Ashford Road Southbound Ahead	U	14	-	284	1915	574	49.4%	284
2/1	Ashford Road Northbound Ahead	U	14	-	275	1915	574	47.9%	275
3/1		U	-	-	275	Inf	Inf	0.0%	275
4/1		U	-	-	284	Inf	Inf	0.0%	284
Item	Leaving (pcu)	Turners In Intergreen (pcu)	Uniform Delay (pcuHr)	Rand + Oversat Delay (pcuHr)	Total Delay (pcuHr)	Av. Delay Per PCU (s/pcu)	Max. Back of Uniform Queue (pcu)	Rand + Oversat Queue (pcu)	Mean Max Queue (pcu)
Network: Barrow Hill Funnel Junction	-	0	2.2	0.9	3.2	-	-	-	-
Ashford Road Junction	-	0	2.2	0.9	3.2	-	-	-	-
1/1	284	-	1.1	0.5	1.6	20.6	3.2	0.5	3.7
2/1	275	-	1.1	0.5	1.6	20.3	3.1	0.5	3.5
3/1	275	-	0.0	0.0	0.0	0.0	0.0	0.0	0.0
4/1	284	-	0.0	0.0	0.0	0.0	0.0	0.0	0.0
C1 PRC for Signalled Lanes (%): 82.1 Total Delay for Signalled Lanes (pcuHr): 3.17 Cycle Time (s): 50 PRC Over All Lanes (%): 82.1 Total Delay Over All Lanes(pcuHr): 3.17									

F.31 J44_Old Dover Road Canterbury

Full Input Data And Results

User and Project Details

Project:	Otterpool Park
Title:	Old Dover Road Canterbury
Location:	
Additional detail:	
File name:	J44_Old Dover Road Canterbury.lsg3x
Author:	Jonathan Gunaserkera
Company:	ARCADIS UK
Address:	

Network Layout Diagram

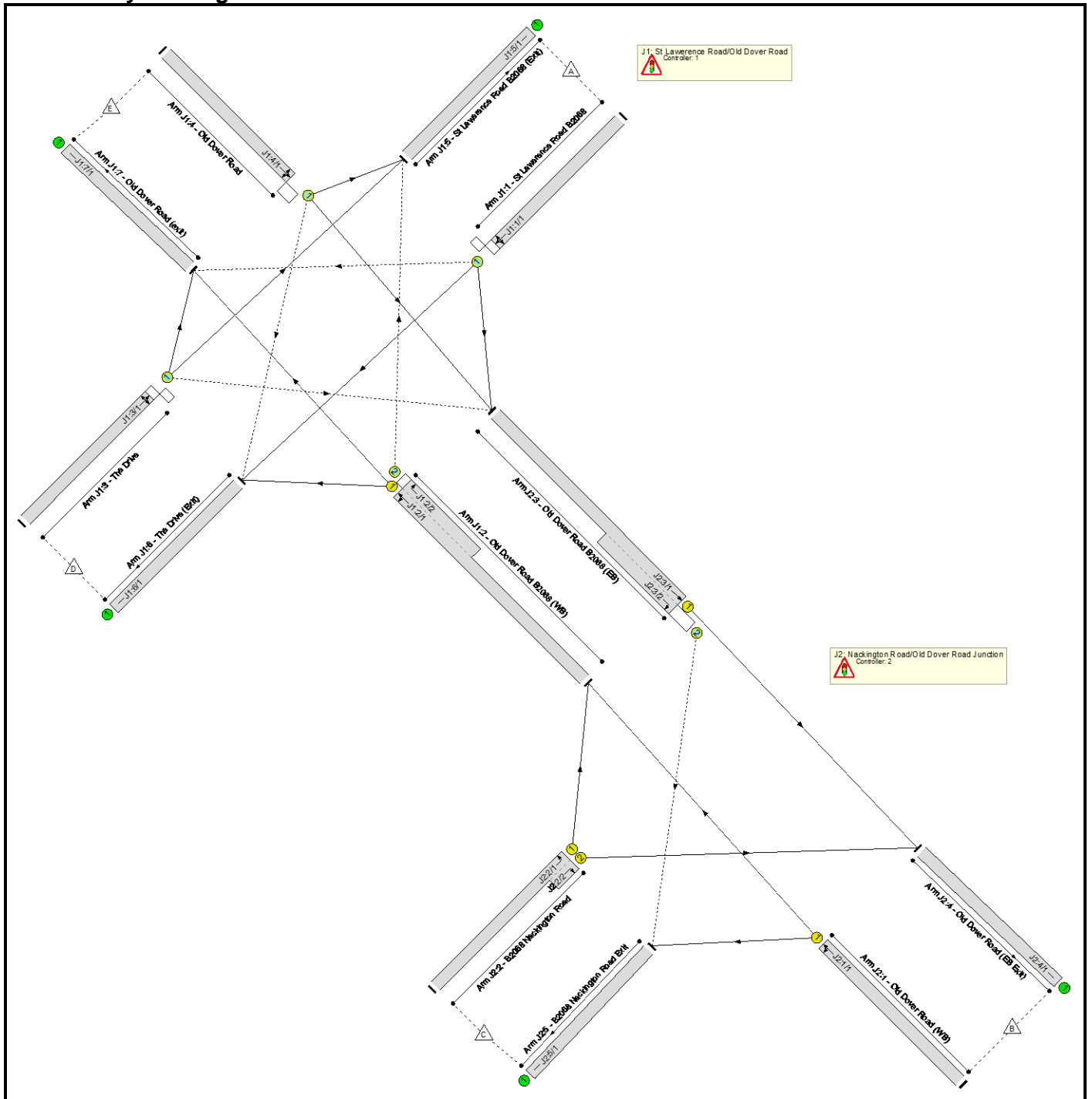

Full Input Data And Results

C1 - B2068 Old Dover / St Lawrence Rd, Canterbury. 06/0

Phase Input Data

Phase Name	Phase Type	Stage Stream	Assoc. Phase	Street Min	Cont Min
A	Traffic	1		-9999	7
B	Traffic	1		-9999	7
C	Traffic	1		-9999	7
D	Traffic	1		-9999	7
E	Ind. Arrow	1	C	-9999	4
F	Pedestrian	1		-9999	6
G	Pedestrian	1		-9999	6
H	Dummy	1		-9999	1
I	Dummy	1		-9999	3
J	Dummy	1		-9999	6
K	Dummy	1		-9999	6

Phase Intergreens Matrix

		Starting Phase										
		A	B	C	D	E	F	G	H	I	J	K
Terminating Phase	A		6	-	6	6	8	8	3	8	8	8
	B	5		5	-	5	5	7	3	7	5	7
	C	-	5		6	-	8	5	3	8	8	5
	D	5	-	5		5	7	8	3	8	7	8
	E	6	5	-	6		8	5	3	8	8	5
	F	8	8	8	8	8		-	4	-	-	-
	G	12	12	12	12	12	-		7	-	-	-
	H	0	0	3	0	3	0	0		-	-	-
	I	-	-	-	-	-	-	-	-		-	-
	J	-	-	-	-	-	-	-	-	-		-
	K	-	-	-	-	-	-	-	-	-	-	

Phases in Stage

Stream	Stage No.	Phases in Stage
1	1	A C
1	2	C E
1	3	F G
1	4	B D

Full Input Data And Results

Stage Diagram

Stage Stream: 1

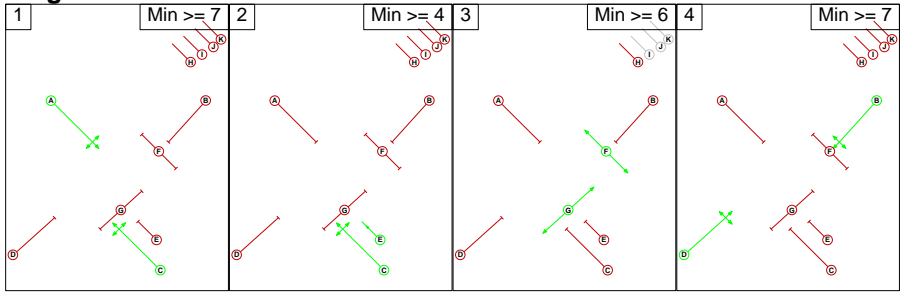

Phase Delays

Stage Stream: 1

Term. Stage	Start Stage	Phase	Type	Value	Cont value
There are no Phase Delays defined					

C2 - B2068 Old Dover Road / Nackington Road - Canterbury. 06/060

Phase Input Data

Phase Name	Phase Type	Assoc. Phase	Street Min	Cont Min
A	Traffic		-9999	7
B	Traffic		-9999	7
C	Traffic		-9999	7
D	Ind. Arrow	A	-9999	4
E	Pedestrian		-9999	6
F	Pedestrian		-9999	7
G	Dummy		-9999	1
H	Dummy		-9999	1
I	Dummy		-9999	6
J	Dummy		-9999	7
K	Filter	C	-9999	4

Full Input Data And Results

Phase Intergreens Matrix

	Starting Phase											
	A	B	C	D	E	F	G	H	I	J	K	
Terminating Phase	A	-	7	-	9	9	3	9	9	9	-	
	B	-	-	7	5	5	8	3	5	5	8	7
	C	5	5	-	5	9	5	3	5	9	5	-
	D	-	6	7	-	9	9	3	9	9	9	-
	E	9	9	9	9	-	-	4	-	-	-	-
	F	13	13	13	13	-	-	8	-	-	-	13
	G	0	0	0	0	0	0	-	0	-	-	-
	H	0	0	0	0	-	-	0	-	-	-	-
	I	-	-	-	-	-	-	-	-	-	-	-
	J	-	-	-	-	-	-	-	-	-	-	-
	K	-	5	-	-	-	5	-	-	-	-	-

Phases in Stage

Stage No.	Phases in Stage
1	A B
2	A D K
3	C
4	E F

Stage Diagram

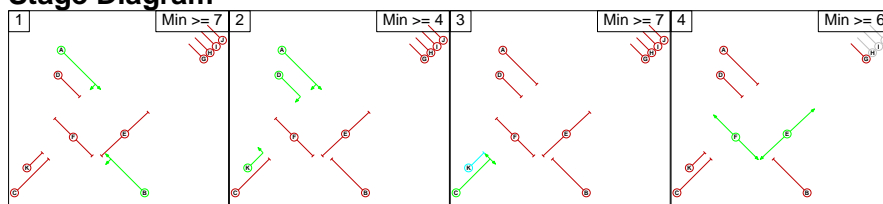

Phase Delays

Term. Stage	Start Stage	Phase	Type	Value	Cont value
There are no Phase Delays defined					

Traffic Flows, Desired

Scenario 1: '2018 AM Peak Hour' (FG13: '2018 TEMPORARY ONLY AM', Plan 1: 'Network Control Plan 1')

Desired Flow :

Origin	Destination						Tot.
	A	B	C	D	E		
A	0	39	99	26	121	285	
B	40	0	67	5	140	252	
C	104	99	0	17	299	519	
D	15	9	23	0	31	78	
E	52	67	171	25	0	315	
Tot.	211	214	360	73	591	1449	

Full Input Data And Results

Scenario 2: '2018 PM Peak Hour' (FG14: '2018 TEMPRO ONLY PM', Plan 1: 'Network Control Plan 1')

Desired Flow :

Origin	Destination						
	A	B	C	D	E	Tot.	
A	0	61	101	13	24	199	
B	36	0	103	13	83	235	
C	59	99	0	24	132	314	
D	33	20	32	0	40	125	
E	63	154	269	44	0	530	
Tot.	191	334	505	94	279	1403	

Scenario 1: '2018 AM Peak Hour' (FG13: '2018 TEMPRO ONLY AM', Plan 1: 'Network Control Plan 1')

C1 - B2068 Old Dover / St Lawrence Rd, Canterbury. 06/0

Stage Sequence Diagram

Stage Stream: 1

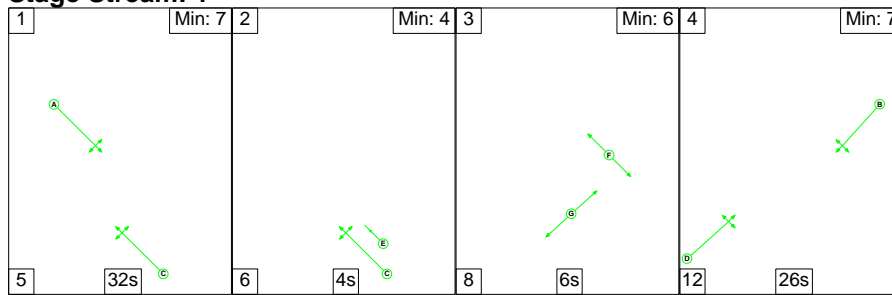

Stage Timings

Stage Stream: 1

Stage	1	2	3	4
Duration	32	4	6	26
Change Point	0	37	47	61

Signal Timings Diagram

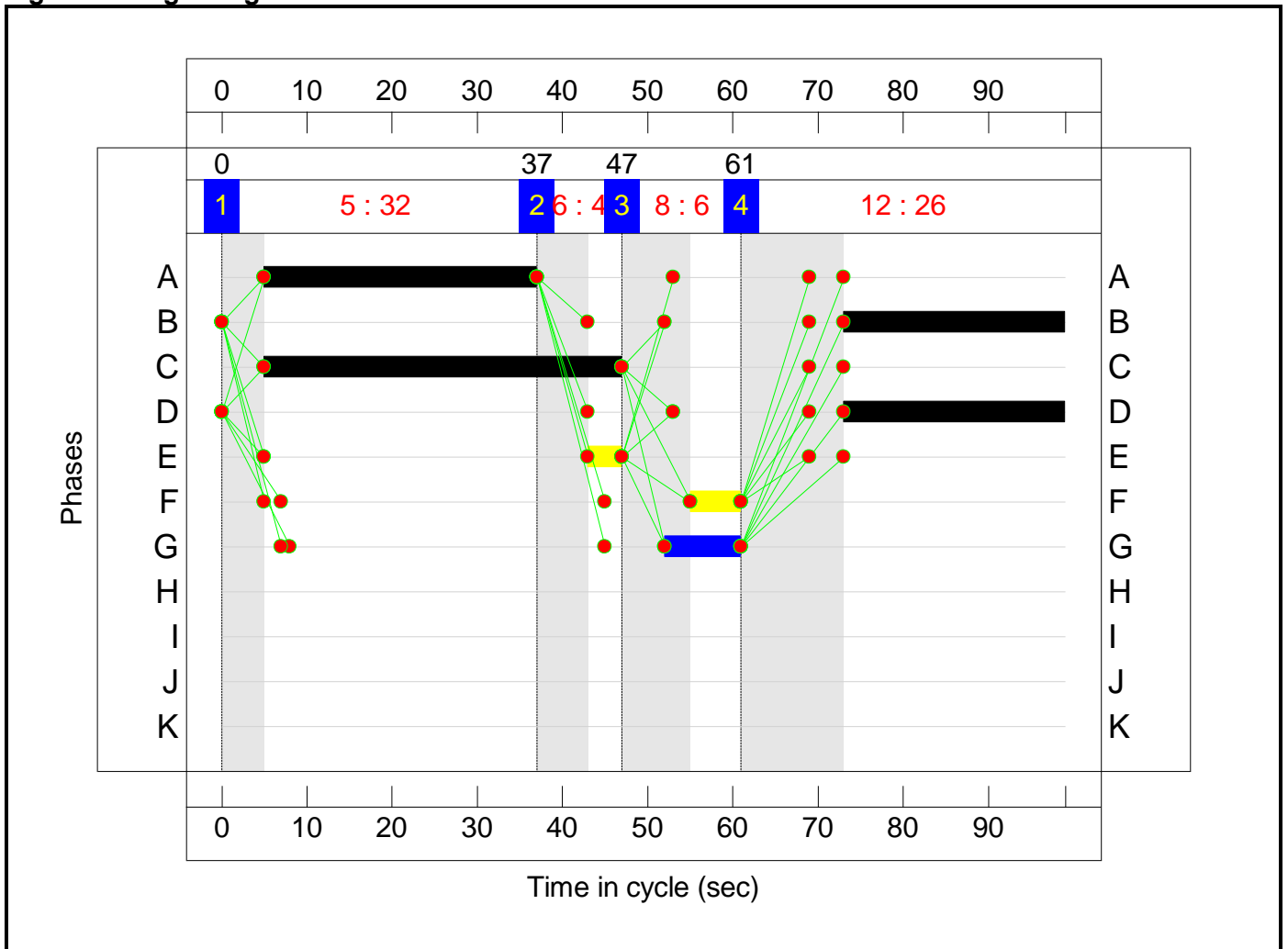

C2 - B2068 Old Dover Road / Nackington Road - Canterbury. 06/060

Stage Sequence Diagram

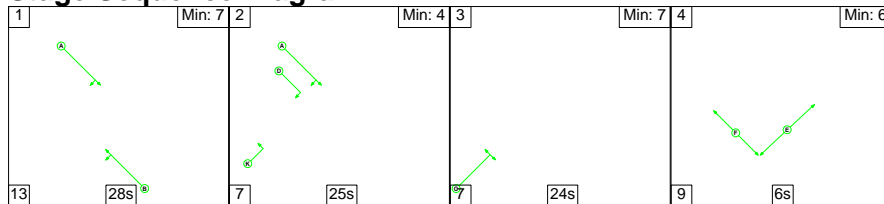

Stage Timings

Stage	1	2	3	4
Duration	28	25	24	6
Change Point	0	41	73	104

Signal Timings Diagram

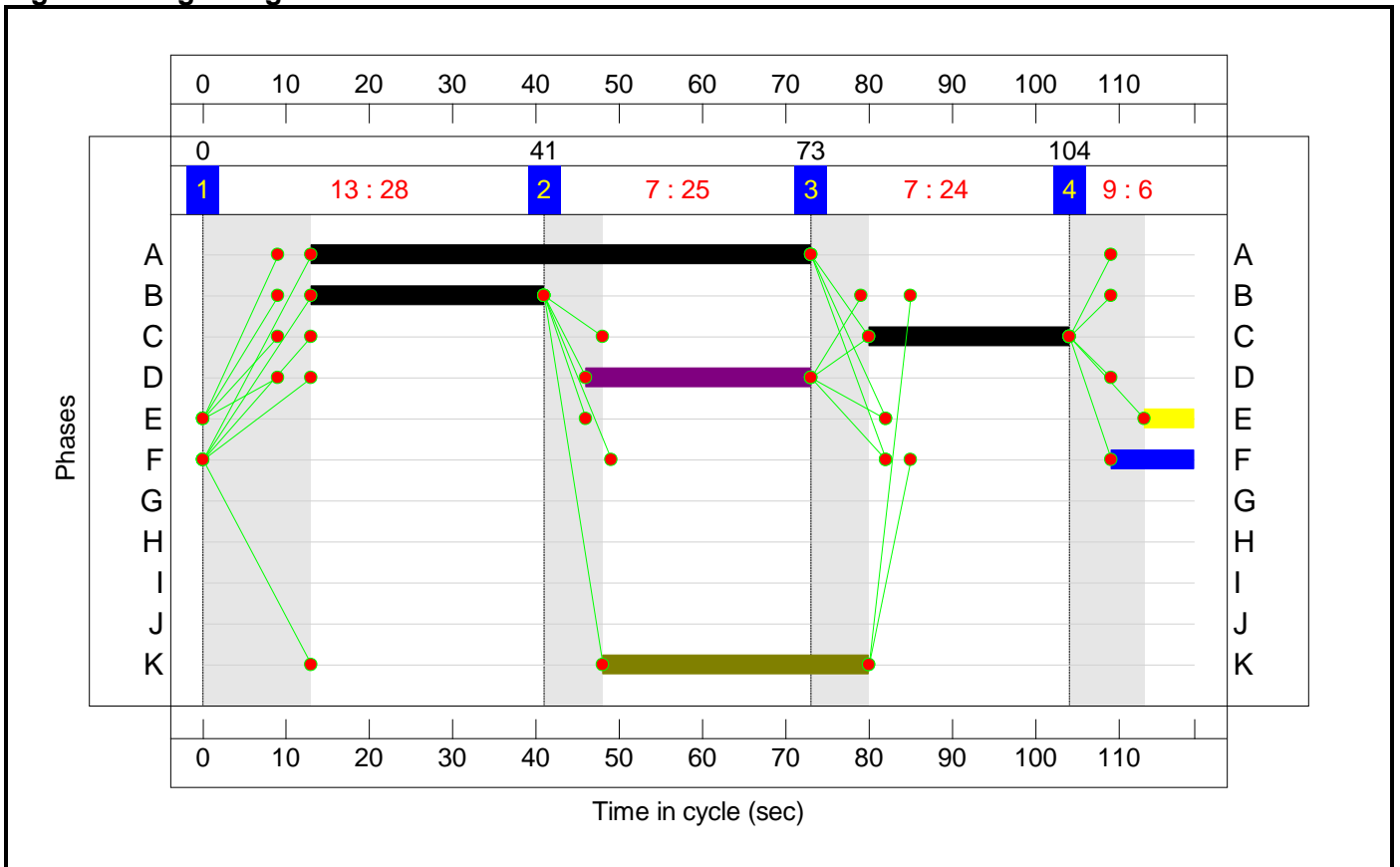

Full Input Data And Results
Network Layout Diagram

Full Input Data And Results

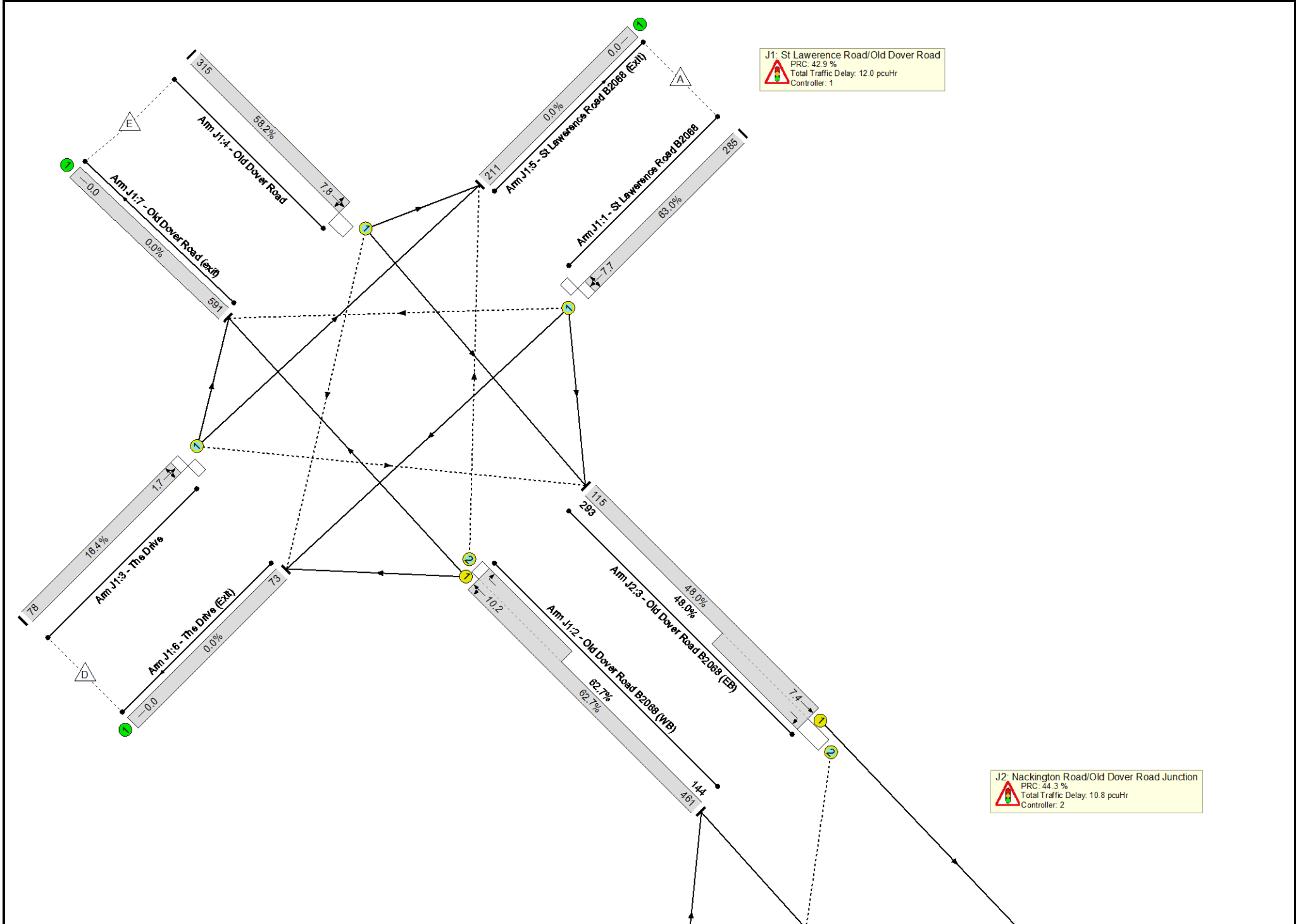

Full Input Data And Results

Network Results

Scenario 1: '2018 AM Peak Hour' (FG13: '2018 TEMPRO ONLY AM', Plan 1: 'Network Control Plan 1')

Item	Lane Description	Lane Type	Total Green (s)	Arrow Green (s)	Demand Flow (pcu)	Sat Flow (pcu/Hr)	Capacity (pcu)	Deg Sat (%)	Arriving (pcu)
Network: Old Dover Road Canterbury	-	-	-	-	-	-	-	63.0%	-
J1: St Lawrence Road/Old Dover Road	-	-	-	-	-	-	-	63.0%	-
1/1	St Lawrence Road B2068 Ahead Right Left	O	26	-	285	1659	452	63.0%	285
2/1+2/2	Old Dover Road B2068 (WB) Right Left Ahead	U+O	42	-	605	1898:1787	735+230	62.7 : 62.7%	605
3/1	The Drive Ahead Left Right	O	26	-	78	1958	474	16.4%	78
4/1	Old Dover Road Left Right Ahead	O	32	-	315	1623	541	58.2%	315
5/1	St Lawrence Road B2068 (Exit)	U	-	-	211	Inf	Inf	0.0%	211
6/1	The Drive (Exit)	U	-	-	73	Inf	Inf	0.0%	73
7/1	Old Dover Road (exit)	U	-	-	591	Inf	Inf	0.0%	591
J2: Nackington Road/Old Dover Road Junction	-	-	-	-	-	-	-	62.4%	-
1/1	Old Dover Road (WB) Ahead Left	U	28	-	252	2034	496	50.8%	252
2/1+2/2	B2068 Nackington Road Left Right	U	56:24	32	519	1743:1787	674+159	62.4 : 62.4%	519
3/1+3/2	Old Dover Road B2068 (EB) Ahead Right	U+O	60	27	408	1915:1787	239+610	48.0 : 48.0%	408
4/1	Old Dover Road (EB Exit)	U	-	-	214	Inf	Inf	0.0%	214
5/1	B2068 Nackington Road Exit	U	-	-	360	Inf	Inf	0.0%	360

Full Input Data And Results

Scenario 2: '2018 PM Peak Hour' (FG14: '2018 TEMPRO ONLY PM', Plan 1: 'Network Control Plan 1')

Item	Lane Description	Lane Type	Total Green (s)	Arrow Green (s)	Demand Flow (pcu)	Sat Flow (pcu/Hr)	Capacity (pcu)	Deg Sat (%)	Arriving (pcu)
Network: Old Dover Road Canterbury	-	-	-	-	-	-	-	74.2%	-
J1: St Lawrence Road/Old Dover Road	-	-	-	-	-	-	-	74.2%	-
1/1	St Lawrence Road B2068 Ahead Right Left	O	15	-	199	1659	268	74.2%	199
2/1+2/2	Old Dover Road B2068 (WB) Right Left Ahead	U+O	53	-	347	1898:1787	871+327	28.9 : 29.0%	347
3/1	The Drive Ahead Left Right	O	15	-	125	1958	169	73.9%	125
4/1	Old Dover Road Left Right Ahead	O	43	-	530	1623	721	73.5%	530
5/1	St Lawrence Road B2068 (Exit)	U	-	-	191	Inf	Inf	0.0%	191
6/1	The Drive (Exit)	U	-	-	94	Inf	Inf	0.0%	94
7/1	Old Dover Road (exit)	U	-	-	279	Inf	Inf	0.0%	279
J2: Nackington Road/Old Dover Road Junction	-	-	-	-	-	-	-	69.8%	-
1/1	Old Dover Road (WB) Ahead Left	U	57	-	235	2034	991	23.7%	235
2/1+2/2	B2068 Nackington Road Left Right	U	27:13	14	314	1743:1787	308+142	69.8 : 69.8%	314
3/1+3/2	Old Dover Road B2068 (EB) Ahead Right	U+O	71	9	637	1915:1787	429+733	54.8 : 54.9%	637
4/1	Old Dover Road (EB Exit)	U	-	-	334	Inf	Inf	0.0%	334
5/1	B2068 Nackington Road Exit	U	-	-	505	Inf	Inf	0.0%	505

F.32 SH16_Canterbury Rd A260 Alkham Valley Rd

Junctions 9
PICADY 9 - Priority Intersection Module
Version: 9.0.2.5947 © Copyright TRL Limited, 2017
For sales and distribution information, program advice and maintenance, contact TRL: +44 (0)1344 770558 software@trl.co.uk www.trlsoftware.co.uk
The users of this computer program for the solution of an engineering problem are in no way relieved of their responsibility for the correctness of the solution

Filename: SH16_Canterbury Rd A260 Alkham Valley Rd_Base Model.j9
Path: K:\UA008926 Otterpool\D-Calcs\Modelling\DM_it5\Appendix\Appendix Base Models\Picady\J30 Canterbury Rd A260 Alkham Valley Rd
Report generation date: 20/11/2018 15:57:54

- »Base, AM
- »Base, PM

Summary of junction performance

	AM				PM			
	Queue (Veh)	Delay (s)	RFC	LOS	Queue (Veh)	Delay (s)	RFC	LOS
Base								
Stream B-C	1.5	21.96	0.61	C	0.5	11.64	0.33	B
Stream B-A	0.5	45.11	0.33	E	0.4	37.66	0.30	E
Stream C-B	0.9	23.23	0.47	C	1.4	25.40	0.58	D

Values shown are the highest values encountered over all time segments. Delay is the maximum value of average delay per arriving vehicle.

File summary

File Description

Title	Canterbury Rd-A260-Alkham Valley Rd
Location	
Site number	
Date	09/04/2018
Version	
Status	
Identifier	
Client	
Jobnumber	
Enumerator	ysa77377 [HCL70027]
Description	

Units

Distance units	Speed units	Traffic units input	Traffic units results	Flow units	Average delay units	Total delay units	Rate of delay units
m	kph	Veh	Veh	perHour	s	-Hour	perHour

Analysis Options

Vehicle length (m)	Calculate Queue Percentiles	Calculate detailed queueing delay	Calculate residual capacity	RFC Threshold	Average Delay threshold (s)	Queue threshold (PCU)
5.75				0.85	36.00	20.00

Demand Set Summary

ID	Scenario name	Time Period name	Description	Traffic profile type	Start time (HH:mm)	Finish time (HH:mm)	Time period length (min)	Time segment length (min)	Run automatically
D1	Base	AM	Canterbury Rd-A260-Alkham Valley Rd	DIRECT	08:00	09:00	60	15	9
D2	Base	PM	Canterbury Rd-A260-Alkham Valley Rd	DIRECT	16:45	17:45	60	15	9

Analysis Set Details

ID	Include in report	Network flow scaling factor (%)	Network capacity scaling factor (%)
A1	9	100.000	100.000

Base, AM

Data Errors and Warnings

No errors or warnings

Junction Network

Junctions

Junction	Name	Junction Type	Major road direction	Junction Delay (s)	Junction LOS
1	untitled	T-Junction	Two-way	4.32	A

Junction Network Options

Driving side	Lighting
Left	Normal/unknown

Arms

Arms

Arm	Name	Description	Arm type
A	Canterbury Rd (West)		Major
B	Alkham Valley Rd		Minor
C	Canterbury Rd (East)		Major

Major Arm Geometry

Arm	Width of carriageway (m)	Has kerbed central reserve	Has right turn bay	Width for right turn (m)	Visibility for right turn (m)	Blocks?	Blocking queue (PCU)
C	6.19		9	3.50	100.0		-

Geometries for Arm C are measured opposite Arm B. Geometries for Arm A (if relevant) are measured opposite Arm D.

Minor Arm Geometry

Arm	Minor arm type	Width at give-way (m)	Width at 5m (m)	Width at 10m (m)	Width at 15m (m)	Width at 20m (m)	Estimate flare length	Flare length (PCU)	Visibility to left (m)	Visibility to right (m)
B	One lane plus flare	10.00	8.06	6.31	4.89	3.67		1.00	65	80

Slope / Intercept / Capacity

Priority Intersection Slopes and Intercepts

Junction	Stream	Intercept (Veh/hr)	Slope for A-B	Slope for A-C	Slope for C-A	Slope for C-B
1	B-A	512	0.093	0.234	0.147	0.334
1	B-C	781	0.119	0.300	-	-
1	C-B	721	0.277	0.277	-	-

The slopes and intercepts shown above do NOT include any corrections or adjustments.

Streams may be combined, in which case capacity will be adjusted.

Values are shown for the first time segment only; they may differ for subsequent time segments.

Traffic Demand

Demand Set Details

ID	Scenario name	Time Period name	Description	Traffic profile type	Start time (HH:mm)	Finish time (HH:mm)	Time period length (min)	Time segment length (min)	Run automatically
D1	Base	AM	Canterbury Rd-A260-Alkham Valley Rd	DIRECT	08:00	09:00	60	15	9

Vehicle mix varies over turn	Vehicle mix varies over entry	Vehicle mix source	PCU Factor for a HV (PCU)
9	9	HV Percentages	2.00

Demand overview (Traffic)

Arm	Linked arm	Profile type	Use O-D data	Scaling Factor (%)
A		DIRECT		100.000
B		DIRECT		100.000
C		DIRECT		100.000

Origin -Destination Data

Demand (Veh/hr)

From	To			
	\$	%	&	
	0	51480	39300	
	2340	0	15180	
	29400	8280	0	

Vehicle Mix

Heavy Vehicle Percentages

From	To		
	\$	%	&
	0	3	1
	5	0	2
	3	0	0

Results

Results Summary for whole modelled period

Stream	Max RFC	Max delay (s)	Max Queue (Veh)	Max LOS	Average Demand (Veh/hr)	Total Junction Arrivals (Veh)
B-C	0.61	21.96	1.5	C	253	253
B-A	0.33	45.11	0.5	E	39	39
C-A					490	490
C-B	0.47	23.23	0.9	C	138	138
A-B					858	858
A-C					655	655

Main Results for each time segment

08:00 - 08:15

Stream	Total Demand (Veh/hr)	Junction Arrivals (Veh)	Capacity (Veh/hr)	RFC	Throughput (Veh/hr)	Start queue (Veh)	End queue (Veh)	Delay (s)	LOS
B-C	253	63	421	0.601	247	0.0	1.4	20.144	C
B-A	39	10	122	0.320	37	0.0	0.4	41.748	E
C-A	490	123			490				
C-B	138	35	293	0.471	135	0.0	0.9	22.311	C
A-B	858	215			858				
A-C	655	164			655				

08:15 - 08:30

Stream	Total Demand (Veh/hr)	Junction Arrivals (Veh)	Capacity (Veh/hr)	RFC	Throughput (Veh/hr)	Start queue (Veh)	End queue (Veh)	Delay (s)	LOS
B-C	253	63	417	0.607	253	1.4	1.5	21.844	C
B-A	39	10	119	0.328	39	0.4	0.5	44.881	E
C-A	490	123			490				
C-B	138	35	293	0.471	138	0.9	0.9	23.205	C
A-B	858	215			858				
A-C	655	164			655				

08:30 - 08:45

Stream	Total Demand (Veh/hr)	Junction Arrivals (Veh)	Capacity (Veh/hr)	RFC	Throughput (Veh/hr)	Start queue (Veh)	End queue (Veh)	Delay (s)	LOS
B-C	253	63	417	0.607	253	1.5	1.5	21.934	C
B-A	39	10	119	0.329	39	0.5	0.5	45.058	E
C-A	490	123			490				
C-B	138	35	293	0.471	138	0.9	0.9	23.226	C
A-B	858	215			858				
A-C	655	164			655				

08:45 - 09:00

Stream	Total Demand (Veh/hr)	Junction Arrivals (Veh)	Capacity (Veh/hr)	RFC	Throughput (Veh/hr)	Start queue (Veh)	End queue (Veh)	Delay (s)	LOS
B-C	253	63	417	0.607	253	1.5	1.5	21.962	C
B-A	39	10	119	0.329	39	0.5	0.5	45.112	E
C-A	490	123			490				
C-B	138	35	293	0.471	138	0.9	0.9	23.235	C
A-B	858	215			858				
A-C	655	164			655				

Base, PM

Data Errors and Warnings

No errors or warnings

Junction Network

Junctions

Junction	Name	Junction Type	Major road direction	Junction Delay (s)	Junction LOS
1	untitled	T-Junction	Two-way	3.35	A

Junction Network Options

Driving side	Lighting
Left	Normal/unknown

Traffic Demand

Demand Set Details

ID	Scenario name	Time Period name	Description	Traffic profile type	Start time (HH:mm)	Finish time (HH:mm)	Time period length (min)	Time segment length (min)	Run automatically
D2	Base	PM	Canterbury Rd-A260-Alkham Valley Rd	DIRECT	16:45	17:45	60	15	9

Vehicle mix varies over turn	Vehicle mix varies over entry	Vehicle mix source	PCU Factor for a HV (PCU)
9	9	HV Percentages	2.00

Demand overview (Traffic)

Arm	Linked arm	Profile type	Use O-D data	Scaling Factor (%)
A		DIRECT		100.000
B		DIRECT		100.000
C		DIRECT		100.000

Origin -Destination Data

Demand (Veh/hr)

		To		
From		\$	%	&
	\$	0	51120	30660
	%	2400	0	9180
	&	42780	11700	0

Vehicle Mix

Heavy Vehicle Percentages

		To		
From		\$	%	&
	\$	0	1	1
	%	0	0	1
	&	0	1	0

Results

Results Summary for whole modelled period

Stream	Max RFC	Max delay (s)	Max Queue (Veh)	Max LOS	Average Demand (Veh/hr)	Total Junction Arrivals (Veh)
B-C	0.33	11.64	0.5	B	153	153
B-A	0.30	37.66	0.4	E	40	40
C-A					713	713
C-B	0.58	25.40	1.4	D	195	195
A-B					852	852
A-C					511	511

Main Results for each time segment

16:45 - 17:00

Stream	Total Demand (Veh/hr)	Junction Arrivals (Veh)	Capacity (Veh/hr)	RFC	Throughput (Veh/hr)	Start queue (Veh)	End queue (Veh)	Delay (s)	LOS
B-C	153	38	467	0.328	151	0.0	0.5	11.353	B
B-A	40	10	138	0.291	38	0.0	0.4	35.832	E
C-A	713	178			713				
C-B	195	49	336	0.579	190	0.0	1.3	23.795	C
A-B	852	213			852				
A-C	511	128			511				

17:00 - 17:15

Stream	Total Demand (Veh/hr)	Junction Arrivals (Veh)	Capacity (Veh/hr)	RFC	Throughput (Veh/hr)	Start queue (Veh)	End queue (Veh)	Delay (s)	LOS
B-C	153	38	463	0.331	153	0.5	0.5	11.630	B
B-A	40	10	136	0.295	40	0.4	0.4	37.567	E
C-A	713	178			713				
C-B	195	49	336	0.579	195	1.3	1.3	25.335	D
A-B	852	213			852				
A-C	511	128			511				

17:15 - 17:30

Stream	Total Demand (Veh/hr)	Junction Arrivals (Veh)	Capacity (Veh/hr)	RFC	Throughput (Veh/hr)	Start queue (Veh)	End queue (Veh)	Delay (s)	LOS
B-C	153	38	462	0.331	153	0.5	0.5	11.637	B
B-A	40	10	136	0.295	40	0.4	0.4	37.634	E
C-A	713	178			713				
C-B	195	49	336	0.579	195	1.3	1.3	25.385	D
A-B	852	213			852				
A-C	511	128			511				

17:30 - 17:45

Stream	Total Demand (Veh/hr)	Junction Arrivals (Veh)	Capacity (Veh/hr)	RFC	Throughput (Veh/hr)	Start queue (Veh)	End queue (Veh)	Delay (s)	LOS
B-C	153	38	462	0.331	153	0.5	0.5	11.639	B
B-A	40	10	136	0.295	40	0.4	0.4	37.657	E
C-A	713	178			713				
C-B	195	49	336	0.579	195	1.3	1.4	25.402	D
A-B	852	213			852				
A-C	511	128			511				

F.33 SH18_Spitfire Way White House Hill A260

Junctions 9
ARCADY 9 - Roundabout Module
Version: 9.0.2.5947 © Copyright TRL Limited, 2017
For sales and distribution information, program advice and maintenance, contact TRL: +44 (0)1344 770558 software@trl.co.uk www.trlsoftware.co.uk
The users of this computer program for the solution of an engineering problem are in no way relieved of their responsibility for the correctness of the solution

Filename: SH18_Spitfire Way White House Hill A260_Base Model.j9
Path: K:\UA008926 Otterpool\D-Calcs\Modelling\DM_it5\Appendix\Appendix Base Models\Arcady\A20 Slip road Spitfire Way Canterbury Rd
Report generation date: 20/11/2018 15:25:06

- »Base, AM
- »Base, PM

Summary of junction performance

	AM				PM			
	Queue (Veh)	Delay (s)	RFC	LOS	Queue (Veh)	Delay (s)	RFC	LOS
Base								
Arm A	0.8	6.85	0.43	A	0.3	4.10	0.26	A
Arm B	1.2	7.17	0.55	A	5.2	15.89	0.85	C
Arm C	0.6	3.65	0.37	A	1.5	6.80	0.61	A
Arm D	3.4	11.22	0.78	B	1.2	5.67	0.54	A

Values shown are the highest values encountered over all time segments. Delay is the maximum value of average delay per arriving vehicle.

File summary

File Description

Title	Spitfire Way-White House Hill-A260
Location	
Site number	
Date	09/04/2018
Version	
Status	
Identifier	
Client	
Jobnumber	
Enumerator	
Description	

Units

Distance units	Speed units	Traffic units input	Traffic units results	Flow units	Average delay units	Total delay units	Rate of delay units
m	kph	Veh	Veh	perHour	s	-Hour	perHour

Analysis Options

Vehicle length (m)	Calculate Queue Percentiles	Calculate detailed queueing delay	Calculate residual capacity	RFC Threshold	Average Delay threshold (s)	Queue threshold (PCU)
5.75				0.85	36.00	20.00

Demand Set Summary

ID	Scenario name	Time Period name	Description	Traffic profile type	Start time (HH:mm)	Finish time (HH:mm)	Time segment length (min)	Run automatically
D1	Base	AM	A20 Slip road Spitfire Way Canterbury Rd	ONE HOUR	08:00	09:30	15	9
D2	Base	PM	A20 Slip road Spitfire Way Canterbury Rd	ONE HOUR	17:00	18:30	15	9

Analysis Set Details

ID	Include in report	Network flow scaling factor (%)	Network capacity scaling factor (%)
A1	9	100.000	100.000

Base, AM

Data Errors and Warnings

No errors or warnings

Junction Network

Junctions

Junction	Name	Junction Type	Arm order	Junction Delay (s)	Junction LOS
1	untitled	Standard Roundabout	A, B, C, D	8.06	A

Junction Network Options

Driving side	Lighting
Left	Normal/unknown

Arms

Arms

Arm	Name	Description
A	White House Hill	
B	A20 Slip Roads	
C	Canterbury Rd	
D	Spitfire Way	

Roundabout Geometry

Arm	V - Approach road half - width (m)	E - Entry width (m)	I' - Effective flare length (m)	R - Entry radius (m)	D - Inscribed circle diameter (m)	PHI - Conflict (entry) angle (deg)	Exit only
A	4.55	6.29	11.0	21.8	43.5	41.0	
B	6.09	8.86	20.7	16.7	43.4	56.0	
C	5.03	8.05	8.0	25.6	42.8	43.0	
D	5.15	7.57	4.1	17.2	42.8	52.0	

Slope / Intercept / Capacity

Roundabout Slope and Intercept used in model

Arm	Final slope	Final intercept (PCU/hr)
A	0.616	1670
B	0.700	2190
C	0.658	1872
D	0.602	1661

The slope and intercept shown above include any corrections and adjustments.

Traffic Demand

Demand Set Details

ID	Scenario name	Time Period name	Description	Traffic profile type	Start time (HH:mm)	Finish time (HH:mm)	Time segment length (min)	Run automatically
D1	Base	AM	A20 Slip road Spitfire Way Canterbury Rd	ONE HOUR	08:00	09:30	15	9

Vehicle mix varies over turn	Vehicle mix varies over entry	Vehicle mix source	PCU Factor for a HV (PCU)
9	9	HV Percentages	2.00

Demand overview (Traffic)

Arm	Linked arm	Profile type	Use O-D data	Average Demand (Veh/hr)	Scaling Factor (%)
A		ONE HOUR	9	366	100.000
B		ONE HOUR	9	552	100.000
C		ONE HOUR	9	516	100.000
D		ONE HOUR	9	1026	100.000

Origin -Destination Data

Demand (Veh/hr)

From	To				
	\$	%	&	'	
\$	0	24	342	0	
%	108	0	192	252	
&	138	18	0	360	
'	0	66	960	0	

Vehicle Mix

Heavy Vehicle Percentages

From	To				
	\$	%	&	'	
\$	0	0	2	0	
%	4	0	4	7	
&	2	26	0	2	
'	4	3	2	0	

Results

Results Summary for whole modelled period

Arm	Max RFC	Max delay (s)	Max Queue (Veh)	Max LOS	Average Demand (Veh/hr)	Total Junction Arrivals (Veh)
A	0.43	6.85	0.8	A	336	504
B	0.55	7.17	1.2	A	507	760
C	0.37	3.65	0.6	A	473	710
D	0.78	11.22	3.4	B	941	1412

Main Results for each time segment

08:00 - 08:15

Arm	Total Demand (Veh/hr)	Junction Arrivals (Veh)	Circulating flow (Veh/hr)	Capacity (Veh/hr)	RFC	Throughput (Veh/hr)	Throughput (exit side) (Veh/hr)	Start queue (Veh)	End queue (Veh)	Delay (s)	LOS
A	276	69	782	1156	0.238	274	185	0.0	0.3	4.075	A
B	416	104	975	1420	0.293	414	81	0.0	0.4	3.573	A
C	388	97	270	1639	0.237	387	1119	0.0	0.3	2.873	A
D	772	193	198	1506	0.513	768	459	0.0	1.0	4.852	A

08:15 - 08:30

Arm	Total Demand (Veh/hr)	Junction Arrivals (Veh)	Circulating flow (Veh/hr)	Capacity (Veh/hr)	RFC	Throughput (Veh/hr)	Throughput (exit side) (Veh/hr)	Start queue (Veh)	End queue (Veh)	Delay (s)	LOS
A	329	82	936	1060	0.310	328	221	0.3	0.4	4.915	A
B	496	124	1168	1289	0.385	495	97	0.4	0.6	4.531	A
C	464	116	323	1603	0.289	463	1340	0.3	0.4	3.159	A
D	922	231	237	1482	0.622	920	550	1.0	1.6	6.376	A

08:30 - 08:45

Arm	Total Demand (Veh/hr)	Junction Arrivals (Veh)	Circulating flow (Veh/hr)	Capacity (Veh/hr)	RFC	Throughput (Veh/hr)	Throughput (exit side) (Veh/hr)	Start queue (Veh)	End queue (Veh)	Delay (s)	LOS
A	403	101	1143	932	0.432	402	270	0.4	0.8	6.771	A
B	608	152	1426	1114	0.545	606	118	0.6	1.2	7.045	A
C	568	142	395	1554	0.366	567	1637	0.4	0.6	3.646	A
D	1130	282	290	1450	0.779	1123	672	1.6	3.4	10.785	B

08:45 - 09:00

Arm	Total Demand (Veh/hr)	Junction Arrivals (Veh)	Circulating flow (Veh/hr)	Capacity (Veh/hr)	RFC	Throughput (Veh/hr)	Throughput (exit side) (Veh/hr)	Start queue (Veh)	End queue (Veh)	Delay (s)	LOS
A	403	101	1149	928	0.434	403	271	0.8	0.8	6.854	A
B	608	152	1433	1109	0.548	608	119	1.2	1.2	7.173	A
C	568	142	396	1553	0.366	568	1645	0.6	0.6	3.652	A
D	1130	282	291	1449	0.779	1129	674	3.4	3.4	11.218	B

09:00 - 09:15

Arm	Total Demand (Veh/hr)	Junction Arrivals (Veh)	Circulating flow (Veh/hr)	Capacity (Veh/hr)	RFC	Throughput (Veh/hr)	Throughput (exit side) (Veh/hr)	Start queue (Veh)	End queue (Veh)	Delay (s)	LOS
A	329	82	946	1055	0.312	330	222	0.8	0.5	4.977	A
B	496	124	1178	1282	0.387	498	98	1.2	0.6	4.606	A
C	464	116	325	1602	0.290	465	1352	0.6	0.4	3.166	A
D	922	231	238	1482	0.623	929	552	3.4	1.7	6.598	A

09:15 - 09:30

Arm	Total Demand (Veh/hr)	Junction Arrivals (Veh)	Circulating flow (Veh/hr)	Capacity (Veh/hr)	RFC	Throughput (Veh/hr)	Throughput (exit side) (Veh/hr)	Start queue (Veh)	End queue (Veh)	Delay (s)	LOS
A	276	69	788	1152	0.239	276	185	0.5	0.3	4.113	A
B	416	104	983	1414	0.294	416	82	0.6	0.4	3.612	A
C	388	97	272	1638	0.237	389	1128	0.4	0.3	2.884	A
D	772	193	199	1506	0.513	775	461	1.7	1.1	4.945	A

Base, PM

Data Errors and Warnings

No errors or warnings

Junction Network

Junctions

Junction	Name	Junction Type	Arm order	Junction Delay (s)	Junction LOS
1	untitled	Standard Roundabout	A, B, C, D	9.86	A

Junction Network Options

Driving side	Lighting
Left	Normal/unknown

Traffic Demand

Demand Set Details

ID	Scenario name	Time Period name	Description	Traffic profile type	Start time (HH:mm)	Finish time (HH:mm)	Time segment length (min)	Run automatically
D2	Base	PM	A20 Slip road Spitfire Way Canterbury Rd	ONE HOUR	17:00	18:30	15	9

Vehicle mix varies over turn	Vehicle mix varies over entry	Vehicle mix source	PCU Factor for a HV (PCU)
9	9	HV Percentages	2.00

Demand overview (Traffic)

Arm	Linked arm	Profile type	Use O-D data	Average Demand (Veh/hr)	Scaling Factor (%)
A		ONE HOUR	9	276	100.000
B		ONE HOUR	9	1110	100.000
C		ONE HOUR	9	738	100.000
D		ONE HOUR	9	678	100.000

Origin -Destination Data

Demand (Veh/hr)

		To				
		\$	%	&	'	
From	\$	0	12	264	0	
	%	198	0	408	504	
	&	168	12	0	558	
	'	0	18	660	0	

Vehicle Mix

Heavy Vehicle Percentages

		To				
		\$	%	&	'	
From	\$	0	0	1	0	
	%	1	0	1	2	
	&	1	0	0	1	
	'	0	0	2	0	

Results

Results Summary for whole modelled period

Arm	Max RFC	Max delay (s)	Max Queue (Veh)	Max LOS	Average Demand (Veh/hr)	Total Junction Arrivals (Veh)
A	0.26	4.10	0.3	A	253	380
B	0.85	15.89	5.2	C	1019	1528
C	0.61	6.80	1.5	A	677	1016
D	0.54	5.67	1.2	A	622	933

Main Results for each time segment

17:00 - 17:15

Arm	Total Demand (Veh/hr)	Junction Arrivals (Veh)	Circulating flow (Veh/hr)	Capacity (Veh/hr)	RFC	Throughput (Veh/hr)	Throughput (exit side) (Veh/hr)	Start queue (Veh)	End queue (Veh)	Delay (s)	LOS
A	208	52	517	1332	0.156	207	274	0.0	0.2	3.199	A
B	836	209	693	1673	0.500	832	31	0.0	1.0	4.262	A
C	556	139	526	1505	0.369	553	999	0.0	0.6	3.773	A
D	510	128	283	1461	0.349	508	796	0.0	0.5	3.772	A

17:15 - 17:30

Arm	Total Demand (Veh/hr)	Junction Arrivals (Veh)	Circulating flow (Veh/hr)	Capacity (Veh/hr)	RFC	Throughput (Veh/hr)	Throughput (exit side) (Veh/hr)	Start queue (Veh)	End queue (Veh)	Delay (s)	LOS
A	248	62	619	1268	0.196	248	328	0.2	0.2	3.527	A
B	998	249	830	1577	0.633	995	38	1.0	1.7	6.160	A
C	663	166	629	1436	0.462	662	1195	0.6	0.9	4.644	A
D	610	152	339	1428	0.427	609	953	0.5	0.7	4.391	A

17:30 - 17:45

Arm	Total Demand (Veh/hr)	Junction Arrivals (Veh)	Circulating flow (Veh/hr)	Capacity (Veh/hr)	RFC	Throughput (Veh/hr)	Throughput (exit side) (Veh/hr)	Start queue (Veh)	End queue (Veh)	Delay (s)	LOS
A	304	76	758	1182	0.257	303	400	0.2	0.3	4.095	A
B	1222	306	1015	1446	0.845	1209	46	1.7	4.9	14.444	B
C	813	203	765	1347	0.603	810	1460	0.9	1.5	6.677	A
D	746	187	413	1383	0.540	745	1161	0.7	1.2	5.623	A

17:45 - 18:00

Arm	Total Demand (Veh/hr)	Junction Arrivals (Veh)	Circulating flow (Veh/hr)	Capacity (Veh/hr)	RFC	Throughput (Veh/hr)	Throughput (exit side) (Veh/hr)	Start queue (Veh)	End queue (Veh)	Delay (s)	LOS
A	304	76	760	1181	0.257	304	403	0.3	0.3	4.103	A
B	1222	306	1017	1445	0.846	1221	46	4.9	5.2	15.893	C
C	813	203	772	1342	0.606	812	1466	1.5	1.5	6.802	A
D	746	187	416	1382	0.540	746	1169	1.2	1.2	5.666	A

18:00 - 18:15

Am	Total Demand (Veh/hr)	Junction Arrivals (Veh)	Circulating flow (Veh/hr)	Capacity (Veh/hr)	RFC	Throughput (Veh/hr)	Throughput (exit side) (Veh/hr)	Start queue (Veh)	End queue (Veh)	Delay (s)	LOS
A	248	62	622	1267	0.196	249	332	0.3	0.2	3.535	A
B	998	249	833	1575	0.634	1012	38	5.2	1.8	6.543	A
C	663	166	640	1429	0.464	666	1204	1.5	0.9	4.733	A
D	610	152	343	1425	0.428	611	963	1.2	0.8	4.432	A

18:15 - 18:30

Am	Total Demand (Veh/hr)	Junction Arrivals (Veh)	Circulating flow (Veh/hr)	Capacity (Veh/hr)	RFC	Throughput (Veh/hr)	Throughput (exit side) (Veh/hr)	Start queue (Veh)	End queue (Veh)	Delay (s)	LOS
A	208	52	520	1330	0.156	208	276	0.2	0.2	3.208	A
B	836	209	697	1670	0.500	839	32	1.8	1.0	4.345	A
C	556	139	530	1502	0.370	557	1005	0.9	0.6	3.812	A
D	510	128	285	1460	0.350	511	802	0.8	0.5	3.798	A

F.34 SH19_Alkham Valley Rd A20 Slip Rd

<h1>Junctions 9</h1>
<h2>ARCADY 9 - Roundabout Module</h2>
Version: 9.0.2.5947 © Copyright TRL Limited, 2017
For sales and distribution information, program advice and maintenance, contact TRL: +44 (0)1344 770558 software@trl.co.uk www.trlsoftware.co.uk
The users of this computer program for the solution of an engineering problem are in no way relieved of their responsibility for the correctness of the solution

Filename: SH19_Alkhams Valley Rd A20 Slip_Base Model.j9
Path: K:\UA008926 Otterpool\D-Calcs\Modelling\DM_it5\Appendix\Appendix Base Models\Arcady\A20 slip road Alkhams Valley Rd
Report generation date: 20/11/2018 15:23:42

- »Base, AM
- »Base, PM

Summary of junction performance

	AM				PM			
	Queue (Veh)	Delay (s)	RFC	LOS	Queue (Veh)	Delay (s)	RFC	LOS
	Base							
Arm A	0.0	1.88	0.03	A	0.0	2.09	0.05	A
Arm B	1.0	3.85	0.50	A	0.3	2.53	0.24	A
Arm C	5.1	17.20	0.84	C	2.8	8.86	0.74	A

There are warnings associated with one or more model runs - see the 'Data Errors and Warnings' tables for each Analysis or Demand Set.

Values shown are the highest values encountered over all time segments. Delay is the maximum value of average delay per arriving vehicle.

File summary

File Description

Title	Alkhams Valley Rd-A20 Slip
Location	
Site number	
Date	09/04/2018
Version	
Status	
Identifier	
Client	
Jobnumber	
Enumerator	ysa77377 [HCL70027]
Description	

Units

Distance units	Speed units	Traffic units input	Traffic units results	Flow units	Average delay units	Total delay units	Rate of delay units
m	kph	Veh	Veh	perHour	s	-Hour	perHour

Analysis Options

Vehicle length (m)	Calculate Queue Percentiles	Calculate detailed queueing delay	Calculate residual capacity	RFC Threshold	Average Delay threshold (s)	Queue threshold (PCU)
5.75				0.85	36.00	20.00

Demand Set Summary

ID	Scenario name	Time Period name	Traffic profile type	Start time (HH:mm)	Finish time (HH:mm)	Time segment length (min)	Run automatically
D1	Base	AM	ONE HOUR	08:00	09:30	15	9
D2	Base	PM	ONE HOUR	17:00	18:30	15	9

Analysis Set Details

ID	Include in report	Network flow scaling factor (%)	Network capacity scaling factor (%)
A1	9	100.000	100.000

Base, AM

Data Errors and Warnings

Severity	Area	Item	Description
Warning	Geometry	Arm B - Roundabout Geometry	Effective flare length is over 30m, which is outside the normal range. Treat capacities with increasing caution.

Junction Network

Junctions

Junction	Name	Junction Type	Arm order	Junction Delay (s)	Junction LOS
1	untitled	Standard Roundabout	A, B, C, D	10.84	B

Junction Network Options

Driving side	Lighting
Left	Normal/unknown

Arms

Arms

Arm	Name	Description
A	A20 Offslip	
B	AlkamValley Rd (East)	
C	AlkamValley Rd (South)	
D	A20 onslip	

Roundabout Geometry

Arm	V - Approach road half - width (m)	E - Entry width (m)	I' - Effective flare length (m)	R - Entry radius (m)	D - Inscribed circle diameter (m)	PHI - Conflict (entry) angle (deg)	Exit only
A	6.71	8.71	13.2	23.7	44.6	38.0	
B	3.82	7.44	37.9	23.3	44.6	40.0	
C	4.13	6.66	19.2	26.5	44.6	34.0	
D							9

Slope / Intercept / Capacity

Roundabout Slope and Intercept used in model

Arm	Final slope	Final intercept (PCU/hr)
A	0.759	2392
B	0.668	1942
C	0.646	1787
D		

The slope and intercept shown above include any corrections and adjustments.

Traffic Demand

Demand Set Details

ID	Scenario name	Time Period name	Traffic profile type	Start time (HH:mm)	Finish time (HH:mm)	Time segment length (min)	Run automatically
D1	Base	AM	ONE HOUR	08:00	09:30	15	9

Vehicle mix varies over turn	Vehicle mix varies over entry	Vehicle mix source	PCU Factor for a HV (PCU)
9	9	HV Percentages	2.00

Demand overview (Traffic)

Arm	Linked arm	Profile type	Use O-D data	Average Demand (Veh/hr)	Scaling Factor (%)
A		ONE HOUR	9	54	100.000
B		ONE HOUR	9	846	100.000
C		ONE HOUR	9	1002	100.000
D					

Origin -Destination Data

Demand (Veh/hr)

		To				
From		\$	%	&	'	
		\$	0	0	54	0
		%	0	0	234	612
		&	0	318	0	684
		'	Exit-only	Exit-only	Exit-only	Exit-only

Vehicle Mix

Heavy Vehicle Percentages

		To				
From		\$	%	&	'	
		\$	0	50	7	0
		%	0	0	1	2
		&	0	4	0	2
		'	Exit-only	Exit-only	Exit-only	Exit-only

Results

Results Summary for whole modelled period

Arm	Max RFC	Max delay (s)	Max Queue (Veh)	Max LOS	Average Demand (Veh/hr)	Total Junction Arrivals (Veh)
A	0.03	1.88	0.0	A	50	74
B	0.50	3.85	1.0	A	776	1164
C	0.84	17.20	5.1	C	919	1379
D						

Main Results for each time segment

08:00 - 08:15

Arm	Total Demand (Veh/hr)	Junction Arrivals (Veh)	Circulating flow (Veh/hr)	Capacity (Veh/hr)	RFC	Throughput (Veh/hr)	Throughput (exit side) (Veh/hr)	Start queue (Veh)	End queue (Veh)	Delay (s)	LOS
A	41	10	238	2060	0.020	41	0	0.0	0.0	1.781	A
B	637	159	41	1881	0.339	635	238	0.0	0.5	2.884	A
C	754	189	459	1447	0.521	750	216	0.0	1.1	5.136	A
D			238				971				

08:15 - 08:30

Arm	Total Demand (Veh/hr)	Junction Arrivals (Veh)	Circulating flow (Veh/hr)	Capacity (Veh/hr)	RFC	Throughput (Veh/hr)	Throughput (exit side) (Veh/hr)	Start queue (Veh)	End queue (Veh)	Delay (s)	LOS
A	49	12	285	2026	0.024	49	0	0.0	0.0	1.820	A
B	761	190	49	1875	0.406	760	285	0.5	0.7	3.226	A
C	901	225	550	1389	0.649	898	259	1.1	1.8	7.291	A
D			285				1163				

08:30 - 08:45

Arm	Total Demand (Veh/hr)	Junction Arrivals (Veh)	Circulating flow (Veh/hr)	Capacity (Veh/hr)	RFC	Throughput (Veh/hr)	Throughput (exit side) (Veh/hr)	Start queue (Veh)	End queue (Veh)	Delay (s)	LOS
A	59	15	346	1980	0.030	59	0	0.0	0.0	1.873	A
B	931	233	59	1867	0.499	930	346	0.7	1.0	3.837	A
C	1103	276	673	1310	0.842	1091	317	1.8	4.8	15.684	C
D			346				1418				

08:45 - 09:00

Arm	Total Demand (Veh/hr)	Junction Arrivals (Veh)	Circulating flow (Veh/hr)	Capacity (Veh/hr)	RFC	Throughput (Veh/hr)	Throughput (exit side) (Veh/hr)	Start queue (Veh)	End queue (Veh)	Delay (s)	LOS
A	59	15	350	1978	0.030	59	0	0.0	0.0	1.875	A
B	931	233	59	1867	0.499	931	350	1.0	1.0	3.846	A
C	1103	276	674	1309	0.843	1102	317	4.8	5.1	17.201	C
D			350				1426				

09:00 - 09:15

Arm	Total Demand (Veh/hr)	Junction Arrivals (Veh)	Circulating flow (Veh/hr)	Capacity (Veh/hr)	RFC	Throughput (Veh/hr)	Throughput (exit side) (Veh/hr)	Start queue (Veh)	End queue (Veh)	Delay (s)	LOS
A	49	12	290	2022	0.024	49	0	0.0	0.0	1.823	A
B	761	190	49	1875	0.406	762	290	1.0	0.7	3.239	A
C	901	225	551	1388	0.649	913	259	5.1	1.9	7.783	A
D			290				1175				

09:15 - 09:30

Arm	Total Demand (Veh/hr)	Junction Arrivals (Veh)	Circulating flow (Veh/hr)	Capacity (Veh/hr)	RFC	Throughput (Veh/hr)	Throughput (exit side) (Veh/hr)	Start queue (Veh)	End queue (Veh)	Delay (s)	LOS
A	41	10	240	2058	0.020	41	0	0.0	0.0	1.786	A
B	637	159	41	1881	0.339	638	240	0.7	0.5	2.899	A
C	754	189	461	1445	0.522	758	217	1.9	1.1	5.258	A
D			240				978				

Base, PM

Data Errors and Warnings

Severity	Area	Item	Description
Warning	Geometry	Arm B - Roundabout Geometry	Effective flare length is over 30m, which is outside the normal range. Treat capacities with increasing caution.

Junction Network

Junctions

Junction	Name	Junction Type	Arm order	Junction Delay (s)	Junction LOS
1	untitled	Standard Roundabout	A, B, C, D	6.82	A

Junction Network Options

Driving side	Lighting
Left	Normal/unknown

Traffic Demand

Demand Set Details

ID	Scenario name	Time Period name	Traffic profile type	Start time (HH:mm)	Finish time (HH:mm)	Time segment length (min)	Run automatically
D2	Base	PM	ONE HOUR	17:00	18:30	15	9

Vehicle mix varies over turn	Vehicle mix varies over entry	Vehicle mix source	PCU Factor for a HV (PCU)
9	9	HV Percentages	2.00

Demand overview (Traffic)

Arm	Linked arm	Profile type	Use O-D data	Average Demand (Veh/hr)	Scaling Factor (%)
A		ONE HOUR	9	78	100.000
B		ONE HOUR	9	408	100.000
C		ONE HOUR	9	1038	100.000
D					

Origin -Destination Data

Demand (Veh/hr)

From	To			
	\$	%	&	'
\$	0	6	72	0
%	0	0	114	294
&	0	630	0	408
'	Exit-only	Exit-only	Exit-only	Exit-only

Vehicle Mix

Heavy Vehicle Percentages

	To				
	\$	%	&	'	
From	\$	0	25	1	0
	%	0	0	1	1
	&	0	1	0	3
	'	Exit-only	Exit-only	Exit-only	Exit-only

Results

Results Summary for whole modelled period

Arm	Max RFC	Max delay (s)	Max Queue (Veh)	Max LOS	Average Demand (Veh/hr)	Total Junction Arrivals (Veh)
A	0.05	2.09	0.0	A	72	107
B	0.24	2.53	0.3	A	374	562
C	0.74	8.86	2.8	A	952	1429
D						

Main Results for each time segment

17:00 - 17:15

Arm	Total Demand (Veh/hr)	Junction Arrivals (Veh)	Circulating flow (Veh/hr)	Capacity (Veh/hr)	RFC	Throughput (Veh/hr)	Throughput (exit side) (Veh/hr)	Start queue (Veh)	End queue (Veh)	Delay (s)	LOS
A	59	15	472	1974	0.030	59	0	0.0	0.0	1.878	A
B	307	77	54	1887	0.163	306	477	0.0	0.2	2.276	A
C	781	195	221	1614	0.484	778	140	0.0	0.9	4.284	A
D			472				526				

17:15 - 17:30

Arm	Total Demand (Veh/hr)	Junction Arrivals (Veh)	Circulating flow (Veh/hr)	Capacity (Veh/hr)	RFC	Throughput (Veh/hr)	Throughput (exit side) (Veh/hr)	Start queue (Veh)	End queue (Veh)	Delay (s)	LOS
A	70	18	565	1905	0.037	70	0	0.0	0.0	1.961	A
B	367	92	65	1880	0.195	367	571	0.2	0.2	2.379	A
C	933	233	264	1587	0.588	931	167	0.9	1.4	5.476	A
D			565				630				

17:30 - 17:45

Arm	Total Demand (Veh/hr)	Junction Arrivals (Veh)	Circulating flow (Veh/hr)	Capacity (Veh/hr)	RFC	Throughput (Veh/hr)	Throughput (exit side) (Veh/hr)	Start queue (Veh)	End queue (Veh)	Delay (s)	LOS
A	86	21	690	1812	0.047	86	0	0.0	0.0	2.085	A
B	449	112	79	1870	0.240	449	697	0.2	0.3	2.533	A
C	1143	286	323	1549	0.738	1138	205	1.4	2.7	8.648	A
D			690				771				

17:45 - 18:00

Arm	Total Demand (Veh/hr)	Junction Arrivals (Veh)	Circulating flow (Veh/hr)	Capacity (Veh/hr)	RFC	Throughput (Veh/hr)	Throughput (exit side) (Veh/hr)	Start queue (Veh)	End queue (Veh)	Delay (s)	LOS
A	86	21	694	1809	0.047	86	0	0.0	0.0	2.088	A
B	449	112	79	1870	0.240	449	700	0.3	0.3	2.533	A
C	1143	286	324	1548	0.738	1143	205	2.7	2.8	8.859	A
D			694				773				

18:00 - 18:15

Arm	Total Demand (Veh/hr)	Junction Arrivals (Veh)	Circulating flow (Veh/hr)	Capacity (Veh/hr)	RFC	Throughput (Veh/hr)	Throughput (exit side) (Veh/hr)	Start queue (Veh)	End queue (Veh)	Delay (s)	LOS
A	70	18	570	1902	0.037	70	0	0.0	0.0	1.965	A
B	367	92	65	1880	0.195	367	575	0.3	0.2	2.382	A
C	933	233	265	1586	0.588	938	167	2.8	1.4	5.599	A
D			570				633				

18:15 - 18:30

Arm	Total Demand (Veh/hr)	Junction Arrivals (Veh)	Circulating flow (Veh/hr)	Capacity (Veh/hr)	RFC	Throughput (Veh/hr)	Throughput (exit side) (Veh/hr)	Start queue (Veh)	End queue (Veh)	Delay (s)	LOS
A	59	15	476	1972	0.030	59	0	0.0	0.0	1.883	A
B	307	77	54	1887	0.163	307	480	0.2	0.2	2.279	A
C	781	195	221	1614	0.484	783	140	1.4	0.9	4.346	A
D			476				529				